

3518  
**JVC**

JL-F30

# SERVICE MANUAL

MODEL

**JL-F30**

FULLY AUTOMATIC TURNTABLE

T.C. Corp  
10 North Main St  
Wharton NJ 07885  
[www.servicemanuals.net](http://www.servicemanuals.net)



# Index

|  | Page |
|--|------|
| 1. Features . . . . .  | 2    |
| 2. Operation . . . . .   | 3~5  |
| 2-1. Construction diagram . . . . .                                  | 3    |
| 2-2. Start mechanism . . . . .                                       | 3    |
| 2-3. Lead-in mechanism . . . . .                                     | 3    |
| 2-4. Return cycle starting mechanism . . . . .                       | 4    |
| 2-5. Repeat mechanism . . . . .                                      | 5    |
| 2-6. Reject mechanism . . . . .                                      | 5    |
| 3. Adjustment . . . . .  | 5~6  |
| 3-1. Lead-in adjustment . . . . .                                    | 5    |
| 3-2. Lead-out adjustment . . . . .                                   | 6    |
| 4. Replacement of Parts . . . . .                                    | 6~7  |
| 4-1. Cartridge . . . . .   | 6    |
| 4-2. Pulley . . . . .  | 7    |
| 4-3. Mechanism chassis . . . . .                                     | 7    |
| 4-4. Voltage setting (U, P Type) . . . . .                           | 7    |
| 5. Lubrication . . . . .   | 7    |
| 6. Troubleshooting . . . . .   | 8    |
| 7. Exploded View of Parts 1 . . . . .                                | 10   |
| 8. List of Parts for Replacement 1 . . . . .                         | 11   |
| 9. Exploded View of Parts 2 . . . . .                                | 12   |
| 10. List of Parts for Replacement 2 . . . . .                        | 12   |
| 11. Exploded View of Parts 3 . . . . .                               | 14   |
| 12. List of Parts for Replacement 3 . . . . .                        | 15   |
| 13. Exploded View of Parts 4 . . . . .                               | 16   |
| 14. List of Parts for Replacement 4 . . . . .                        | 16   |
| 15. Final Packing Ass'y . . . . .                                    | 18   |
| 16. Accessories . . . . .  | 19   |
| 17. Schematic Diagram . . . . .                                      | 19   |
| 18. Parts List with Specified Numbers for Designated Areas . . . . . | 20   |
| 19. Specifications . . . . .   | 21   |

## 1. Features

### Fully automatic mechanism

- \* Automatic playing for records of all sizes — 30, 25, 17cm (12", 10", 7").
- \* Cueing facility protects the record surface during manual playing.
- \* Repeat memory facility for automatic playing repetition. Set the dial to hear up to six repetitions of a record. Or set it for infinite repetition.
- \* Automatic reject facility  
To stop playing a record at any point, push the START/REJECT operation lever towards "REJECT", and the tonearm will automatically returns to the arm rest.

### New gimbal support arm

Outstanding tone arm sensitivity is assured, because bearings for clockwise/counterclockwise rotation are provided above and under the pivot bearing.

Trackability is thanks to the TH (Tracking Hold) system — the axis of the balance weight is positioned lower than the pivot bearing, so superb tracking characteristics are maintained even if a record is warped or if there is external vibration.

### Belt-drive system

A drive belt connects the motor pulley to the platter. Because motor vibration is not transferred directly to the platter, the signal-to-noise ratio is much higher than that of rim-driven turntables.

### Large platter (0.5mil diamond tip)

30.9cm diameter aluminum die-cast platter.

### Diamond stylus

### Anti-skating mechanism

Anti-skating force can be adjusted corresponding to the tracking force.

# 2. Operation

## 2-1. Construction diagram

Mechanical components

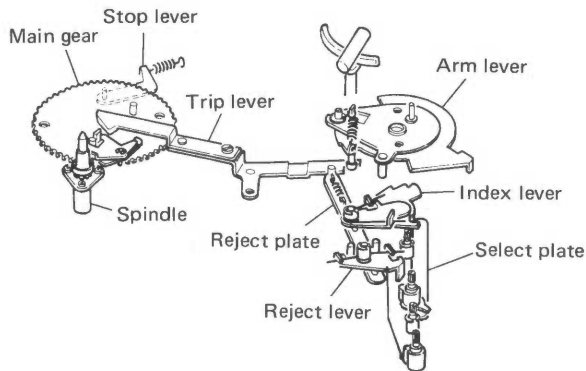

Fig. 1

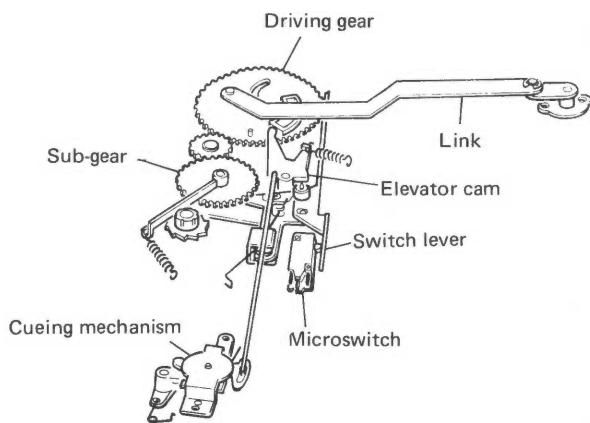

Fig. 2

As shown in Fig. 3, when the start/reject rod is pushed in the direction of arrow (a) the reject lever connected to the rod turns in the direction of arrow (b). At this revolution, the reject plate is pushed by the spring (1), and the engagement shoe is moved in the direction of arrow (c), beginning the starting cycle operation.

At the same time, as the reject lever is pushed in the direction of (b), the boss (B) of the ratchet cam is engaged by arm (A) to rotate the cam in the direction of (d). Consequently the reset plate is pushed away in the direction of (e).

As a result, the switch lever (C) is moved in the direction of (f), and is released from the microswitch, which turns on the power. (This microswitch become conductive when it is separated from the switch lever.)

Fig. 4 shows the position described above.

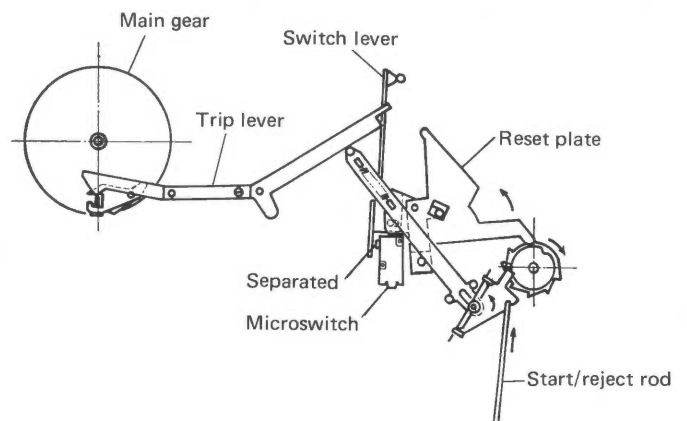

Fig. 4

## 2-2. Start mechanism

When the START/REJECT operation lever is pulled toward "START", the mechanism operates as shown in Fig. 3 to power the platter and carry the tonearm to the specified position on the record surface.

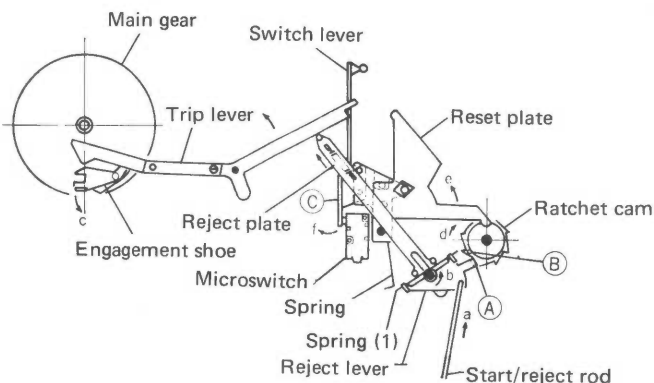

Fig. 3

## 2-3. Lead-in mechanism

When the starting cycle begins and the main gear rotates, the driving gear is turned reciprocally by the link to reciprocate the elevator cam, as shown in Fig. 5.

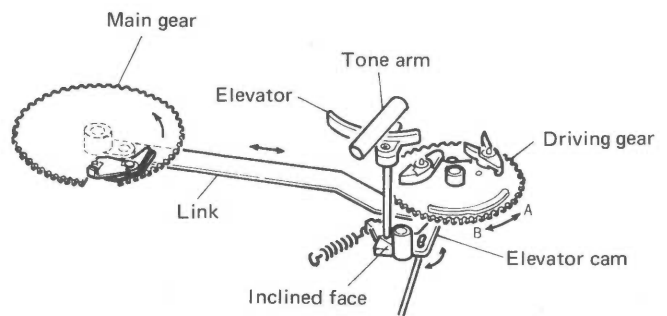

Fig. 5

As the elevator cam moves, its inclined face lifts the elevator, which in turn lifts the tonearm.

In Fig. 6, the lead-in lever is moved in the direction (a) by the counterclockwise rotation (A) of the driving gear, as shown in Fig. 5. As a result, the lead-in lever passes the arm lever stud (A) without touching it. Therefore, the arm lever does not move. During the next process shown in Fig. 7, the lead-in lever strikes against the reset plate and is pushed back in the direction (a). When the driving gear returns in the clockwise direction (B), this time the lead-in lever pushes the arm lever stud (B), and the arm lever stud is moved in the direction of the arrow, as shown in Fig. 8. This finishes the final stage of the lead-in operation.

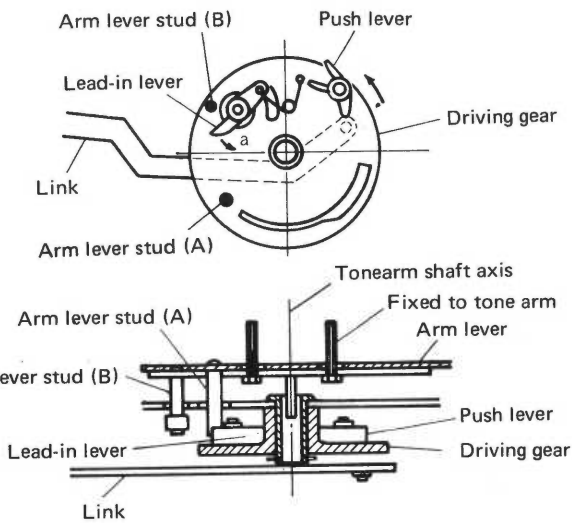

Fig. 6

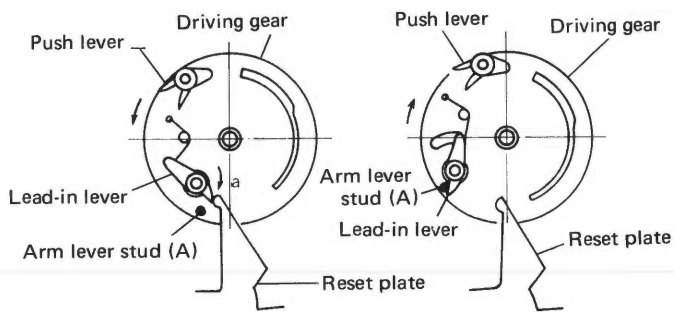

Fig. 7

Fig. 8

The stylus is positioned at the beginning of a record according to the record size (17, 25, or 30cm) chosen with the Record Size Select knob. The stylus position is determined by one of three steps on the index lever shown in Fig. 9. Part (A) of the arm lever engages the corresponding step on the index lever.

Turning this eccentric adjustment screw will move the arm lever to fine-adjust the stylus lead-in position.

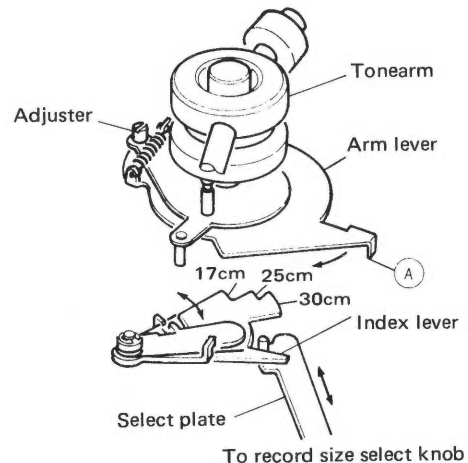

Fig. 9

#### 2-4. Return cycle starting mechanism

The relationship between the notch in the main gear and the platter gear while a record is being played is shown in Fig. 10. In this condition the main gear does not rotate as the platter rotates because the platter gear and main gear are not engaged. As playing proceeds, however, the arm lever presses the trip lever to move forward gradually the lower trip and the engagement shoe on the main gear.

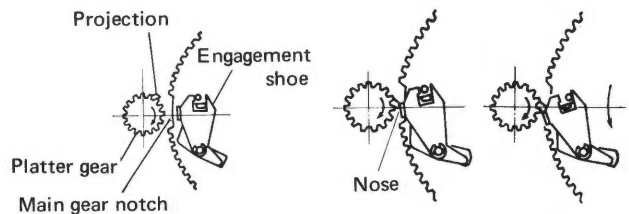

Fig. 10

Fig. 11

Fig. 12

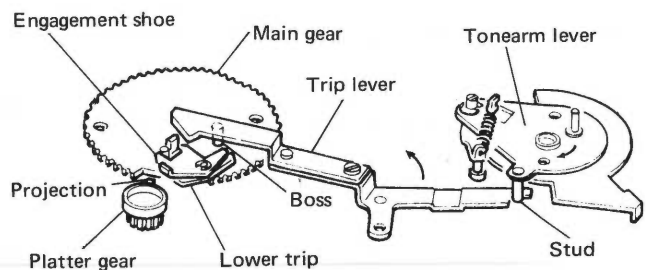

Fig. 13

The relationship between the engagement shoe and the platter gear comes to a state shown in Fig. 11. In this condition, during the time in which the pitch of the grooves is small, the movement of the engagement shoe is small. The engagement shoe is thus pushed back by the nose of the engagement shoe, the main gear being still.

When the stylus comes into the lead-out groove having a large pitch at the end of a record, the movement of the engagement shoe becomes larger than the reverse movement caused by the projection nose, entering the state which is shown in Fig. 12, where the projection presses the engagement shoe to cause the main gear to rotate.

When the main gear notch moves away, both gears come into engagement, starting the returning cycle.

After one complete revolution of the main gear, it will return to the position as shown in Fig. 10. The main gear will stop rotating while the platter gear is still turning.

As the main gear turns, the engagement shoe and the lower trip are returned by the outer edge of the platter gear to the original position just before the rotation of the main gear is finished. The trip lever also returns to its original position on the boss on the face of main gear halfway through the main gear rotation.

## 2-5. Repeat mechanism

Setting the REPEAT knob to one of the positions "1" through "6" will cause the tonearm to return from the end of record to the beginning lead-in position and play it again. The same process will be repeated up to six times, depending on the setting. Setting the knob to "R" will cause the tonearm to play the record over and over again endlessly.

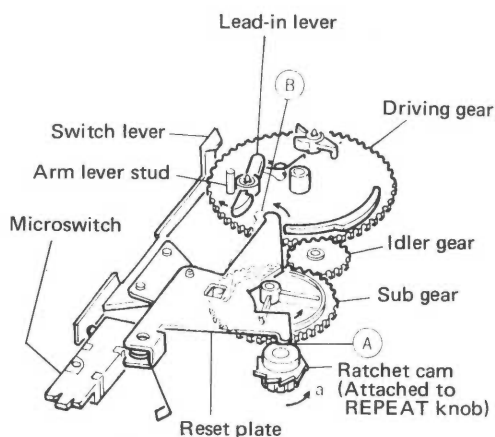

Fig. 14

As shown in Fig. 14, when the ratchet cam is turned in the direction of arrow (a) (toward the position "R" on the REPEAT knob), the part (A) of the reset plate is pushed away by the outer circumference of the ratchet cam until its part (B) is moved as far as the dotted line. Thus, the lead-in lever on the driving gear is always returned by the reset plate and pushes the arm lever stud back to bring the arm lever to the lead-in position, and the record is played again. At the "R" position the hook on the sub gear passes over the toothless section of the ratchet cam, so the cam does not turn.

If the ratchet cam is set to one of the positions "1" through "6" on the REPEAT knob, the ratchet cam and the hook on the sub gear engage after every time one record has been played, as shown in Fig. 15.

Thus the cam turns one step for each cycle. After completion of the specified number of cycles the ratchet cam and hook do not engage, and the reset plate returns to the position as shown in Fig. 14. The tonearm is returned to the arm rest, and the power is switched off when the switch plate presses the microswitch.

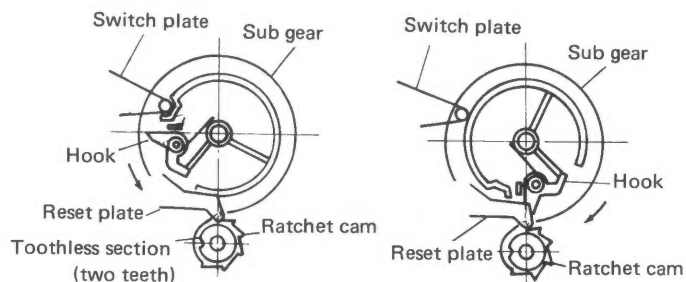

Fig. 15

## 2-6. Reject mechanism

If the START/REJECT lever is pushed toward "REJECT" while a record is playing, the start/reject rod moves in the direction of arrow (a), and the reject plate and trip lever are pushed by the spring (1), as shown in Fig. 16. As a result of this, the engagement shoe is moved out in the direction of arrow (c), beginning the change cycle.

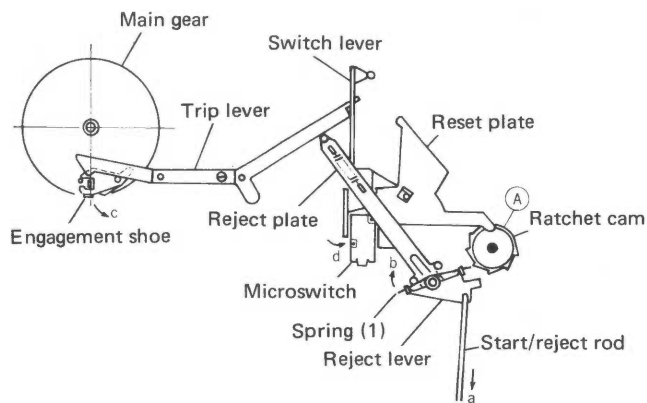

Fig. 16

If the REPEAT knob is at "1", the reset plate engages with the section (A) of the ratchet cam, and the switch lever moves in the direction of (d) to push the microswitch, turning the power off.

# 3. Adjustment

## 3-1. Lead-in adjustment

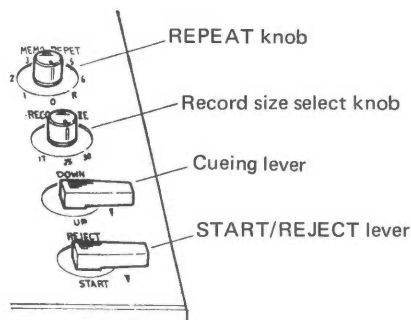

Fig. 17

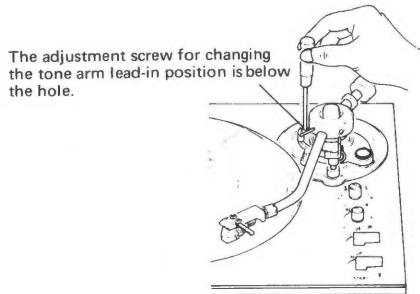

Fig. 18

The stylus lead-in position has been adjusted at the factory so that the stylus lands correctly onto the lead-in groove of a record. However, the position may need adjustment if the tonearm is replaced. Follow these steps to adjust the lead-in position:

1. Put the 30cm JVC test record (RG324) on the platter.
2. Set the RECORD SIZE select knob to "17", and start automatic playing. If the stylus comes in contact with the test record while the voice is counting in a range between 7 and 29, the lead-in position is correct. If not, turn the adjustment screw with a minus screwdriver clockwise to move the lead-in position towards the center of the record, where the lead-in count increases, or counterclockwise to move the lead-in position towards the outer rim of the record, when the lead-in count decreases.

**Note:** The normal lead-in count range is shown below. If you adjust so that the lead-in count is 18 for a 17cm record, the lead-in count for both 25cm and 30cm records will be automatically set within the normal range.

(The JL-F30 for U.S.A. and Canada has a cap covering the hole for the adjusting screw. Remove the cap at the adjustment.)

| Normal lead-in count range | Record size |
|----------------------------|-------------|
| 7 – 29                     | 17cm ( 7")  |
| 13 – 38                    | 25cm (10")  |
| 5 – 34                     | 30cm (12")  |

### 3-2. Lead-out adjustment

The correct lead-out adjustment has also been made at the factory, but the adjustment is necessary after replacement of a tonearm or for other reasons, follow the steps below. Fig. 19 shows the mechanism after removal of the platter.

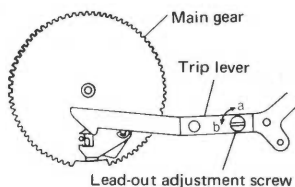

Fig. 19

**\* If lead-out does not occur:**

Play the 17cm JVC test record (RG652) having a lead-out groove pitch of 3mm. If the change cycle does not begin when the stylus reaches the lead-out groove, turn the lead-out adjustment screw clockwise in the direction of arrow (a) as shown in Fig. 19.

**\* If lead-out occurs too soon:**

If the change cycle begins before the stylus comes to the lead-out groove of the 17cm JVC test record (RG653, back side of RG652) turn the screw counterclockwise in the direction of arrow (b).

**Caution:** Unplug the power cord first.

1. Clamp the tonearm to the arm rest.
2. Remove the dust cover.
3. Remove the rubber mat, the platter, and the belt.
4. Turn the set upside down, and place it on blocks to protect the tonearm assembly, spindle shaft and pulley.
5. After removing the signal and power cord assemblies from the bottom board, remove the seven screws fixing the bottom board.

## 4. Replacement of Parts

### 4-1. Cartridge

1. Unscrew the connector nut to remove the headshell.
2. Remove the two long screws on the headshell which hold the cartridge.
3. Connect the lead wires of the headshell to the new cartridge, being careful to match the polarities correctly. Polarity and wire colors are as follows:  
 White (+) ..... L    Red (+) ..... R  
 Blue (-) ..... LE    Green (-) ..... RE
4. Attach the cartridge to the headshell squarely, and gently tighten the screws.
5. Set the cueing lever to "DOWN", and then bring the stylus tip to the overhang indicator by sliding the cartridge back and forth. After the adjustment, fix it firmly.
6. After attaching the cartridge, slide the headshell into the tonearm with the connector pin fitting in the groove. Tighten the connector nut.
7. Be sure to adjust the tracking force and lead-in position after replacing the cartridge.

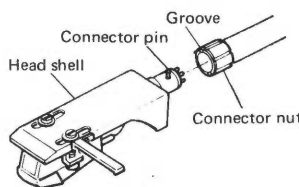

Fig. 20

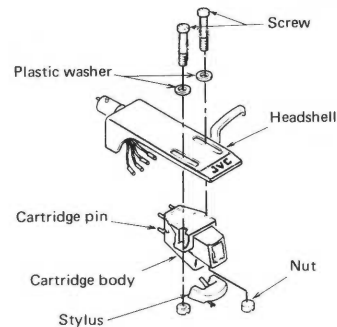

Fig. 21

#### 4-2. Pulley

The motor R.P.M. of a platter will vary greatly depending on the frequency of the power source. Replace the pulley if you use a turntable at a different frequency.

(There is no need to alter the wiring of the motor.)

1. Remove the platter.
2. When you replace the pulley, adjust the height of the new pulley so that the center of the shift lever is as shown in Fig. 22 when the speed selector knob is set to "33".

**Caution:** Be sure to remove the drive belt from the pulley before removing the platter. It is difficult to lift up the platter if it fits firmly on the center shaft. In such a case, tap the top of the center shaft gently with the handle of a screwdriver while lifting up the platter.

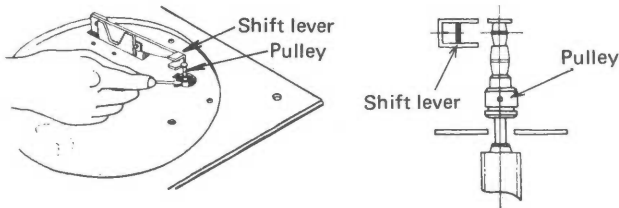

Fig. 22

**Note:** Difference between 50Hz and 60Hz pulleys is illustrated in Fig. 23.

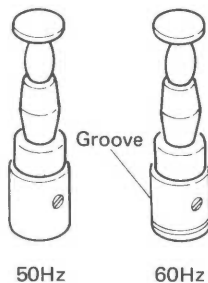

Fig. 23

#### 4-3. Mechanism chassis

When you replace the entire mechanism (or the driving gear only), be sure to check that the lead-in lever attached to the driving gear has been returned in the direction of arrow (a) as shown in Fig. 24. (The lead-in lever faces in the direction of arrow (b), the mechanism may malfunction or be damaged.)

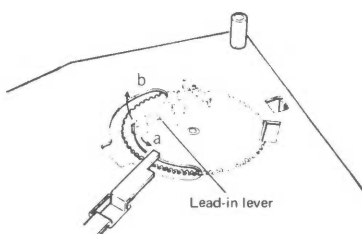

Fig. 24

#### 4-4. Voltage setting

(In U.S. MILITARY MARKET and OTHER AREAS)

As with most A.C. motors, the JL-F30's motor has to be set to the proper line voltage.

When it is used at a different line voltage, set it to "110" in areas with power line voltages from 110V to 120V and "230" in 220V to 240V areas.

The line voltage setting switch is located at the circuit board (TSC-60C), which is found by removing the bottom board (E10101-001). Slide the switch to the proper position.

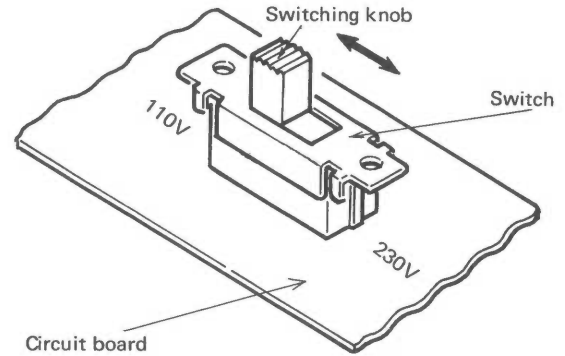

Fig. 25

## 5. Lubrication

The motor incorporated in this model can be used for 800 – 1,600 hours without lubrication because of its heavy-duty oil reservoir.

Use a high quality sewing machine oil to lubricate the pulley shaft (A) as shown in Fig. 26 for every 1,000 – 2,000 hours of operation under normal use. Be sure to unplug the power cord before lubrication. For professional or frequent use, lubricate once or twice a month.

\* Be sure to remove the drive belt from the pulley before removing the platter.

Hit the top of the center shaft gently with the handle of a screwdriver if the platter is firmly connected to the center shaft.

\* Be careful not to stain the pulley, belt or platter with oil. If stained, clean with alcohol.

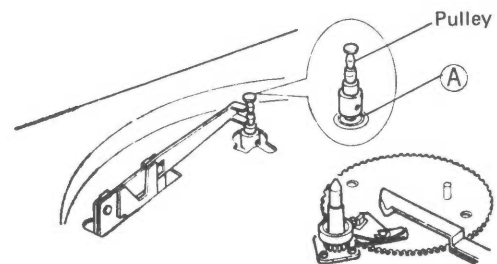

Fig. 26

## 6. Troubleshooting

| Sympton   | Cause   | Remedies   |
|---|---|--|
| Platter does not rotate when tonearm is moved to record manually or by automatic start operation. | <ol style="list-style-type: none"> <li>1. Motor is not powered.</li> <li>2. Drive belt is incorrectly installed.</li> <li>3. Motor is defective.</li> <li>4. Switch lever remains in contact with switch.</li> </ol>  | <ul style="list-style-type: none"> <li>* Check that the power cord is plugged in.</li> <li>* Check for disconnected wires or defective soldering.</li> <li>* Check if switch is damaged.</li> <li>* Check that the belt is correctly placed over the pulley.</li> <li>* Replace the motor if the motor does not rotate when power is supplied to the motor terminals.</li> <li>* Adjust the switch lever for correct clearance.</li> </ul> |
| Platter speed is not correct.   | <ol style="list-style-type: none"> <li>1. Motor bearings are too tight.</li> <li>2. Pulley.</li> <li>3. Drive belt.</li> </ol>  | <ul style="list-style-type: none"> <li>* Replace.</li> <li>* Check that the correct pulley is attached according to the local power frequency (50Hz, 60Hz).</li> <li>* Check if the drive belt slips on the pulley when the speed is changed. If it slips, clean the pulley and belt.</li> </ul>   |
| Tonearm does not lead-in. (Player does not start.)  | <ol style="list-style-type: none"> <li>1. Platter does not rotate.</li> <li>2. Change cycle does not start.</li> <li>3. Lead-in lever on driveing gear is turned toward the outside of the gear and is blocked by the arm lever stud.</li> </ol>  | <ul style="list-style-type: none"> <li>* Refer to the above-mentioned column.</li> <li>* Check that the engagement shoe is operated smoothly, and that it is pushed away fully when the start knob is pulled.</li> <li>* Set lead-in lever to the proper inward position.</li> </ul>   |
| Tonearm lead-in position goes out of adjustment.  | <ol style="list-style-type: none"> <li>1. Arm lever adjuster is not firmly fixed, allowing movement.</li> </ol>   | <ul style="list-style-type: none"> <li>* Be sure to tighten the knurled washer to lock the adjuster.</li> </ul>  |
| Arm lifter moves incorrectly.   | <ol style="list-style-type: none"> <li>1. The lead wires of the tonearm are too tight of tangled.</li> <li>2. The tonearm pipe slips on elevator.</li> </ol>  | <ul style="list-style-type: none"> <li>* Slacken the lead wires to avoid any unwanted force on the tonearm pivot.</li> <li>* Wipe the elevator face.</li> </ul>  |
| Tonearm does not stop at the correct position of a record, and moves to the inside.               | <ol style="list-style-type: none"> <li>1. Index lever does not operate correctly.</li> </ol>  | <ul style="list-style-type: none"> <li>* Check that the index lever operates smoothly, under the action of the spring.</li> </ul>  |
| Change cycle will not stop.   | <ol style="list-style-type: none"> <li>1. Trip lever and engagement shoe of the main gear malfunction.</li> </ol>   | <ul style="list-style-type: none"> <li>* Check that trip lever returns after completing the change cycle, and that the engagement shoe moves smoothly and freely.</li> </ul>   |
| No sound is reproduced while playing.   | <ol style="list-style-type: none"> <li>1. Cartridge is defective.</li> <li>2. Wiring is not correct.</li> <li>3. Stylus is defective.</li> <li>4. Amplifier is defective.</li> </ol>  | <ul style="list-style-type: none"> <li>* Replace.</li> <li>* Check the wiring.</li> <li>* Replace.</li> </ul>  |
| Stylus does not follow the groove correctly.  | <ol style="list-style-type: none"> <li>1. Dust or foreign matter is in the record groove.</li> <li>2. Stylus is dirty or defective.</li> <li>3. Lead wires in the tonearm are tangled or too tight.</li> <li>4. Tracking force is abnormal.</li> <li>5. Tonearm bearings have too much friction.</li> </ol> | <ul style="list-style-type: none"> <li>* Clean.</li> <li>* Clean or replace.</li> <li>* Slacken the wires.</li> <li>* Adjust.</li> <li>* Replace tonearm.</li> </ul>   |



| Sympton   | Cause   | Remedies  |
|---|---|---|
| Motor rumble is heard while playing.                              | <ol style="list-style-type: none"> <li>1. Motor is defective.</li> <li>2. Motor is mounted incorrectly.</li> </ol>                            | <ul style="list-style-type: none"> <li>* Check if any part of motor is in contact with the base or mechanism.</li> <li>* Check if mounting board is in contact with the motor board.</li> </ul>   |
| Tonearm does not lead-out.  | <ol style="list-style-type: none"> <li>1. The lead-out groove is not standard.</li> <li>2. Stylus does not advance.</li> </ol>                | <ul style="list-style-type: none"> <li>* It may not lead out when old or non-standard records such as film records are used.</li> <li>* Lead-out will not occur if the pitch of the lead-out groove is less than 3mm.</li> <li>* Check if the tracking force is correct. Check if trip mechanism does not operate smoothly.</li> <li>* Check if the stylus tip is damaged dirty.</li> </ul> |
| Reject does not work.   | <ol style="list-style-type: none"> <li>1. Engagement shoe is not pushed away fully.</li> </ol>  | <ul style="list-style-type: none"> <li>* Check the trip mechanism.</li> </ul>   |
| Repeat does not work.   | <ol style="list-style-type: none"> <li>1. Switch plate malfunctions, and switch turns off.</li> </ol>   | <ul style="list-style-type: none"> <li>* Check that switch plate and reset plate operate smoothly.</li> </ul>   |
| Player does not shut off.   | <ol style="list-style-type: none"> <li>1. REPEAT knob is set for repeat playing.</li> </ol>   | <ul style="list-style-type: none"> <li>* Set the knob to "0".</li> </ul>  |
| Power does not turn off after reject with the REPEAT knob at "0". | <ol style="list-style-type: none"> <li>1. Switch if defective.</li> <li>2. Switch button is not fully pressed by the switch lever.</li> </ol> | <ul style="list-style-type: none"> <li>* Replace.</li> <li>* Adjust so that lever fully presses the switch button.</li> </ul>   |

# 7. Exploded View of Parts 1

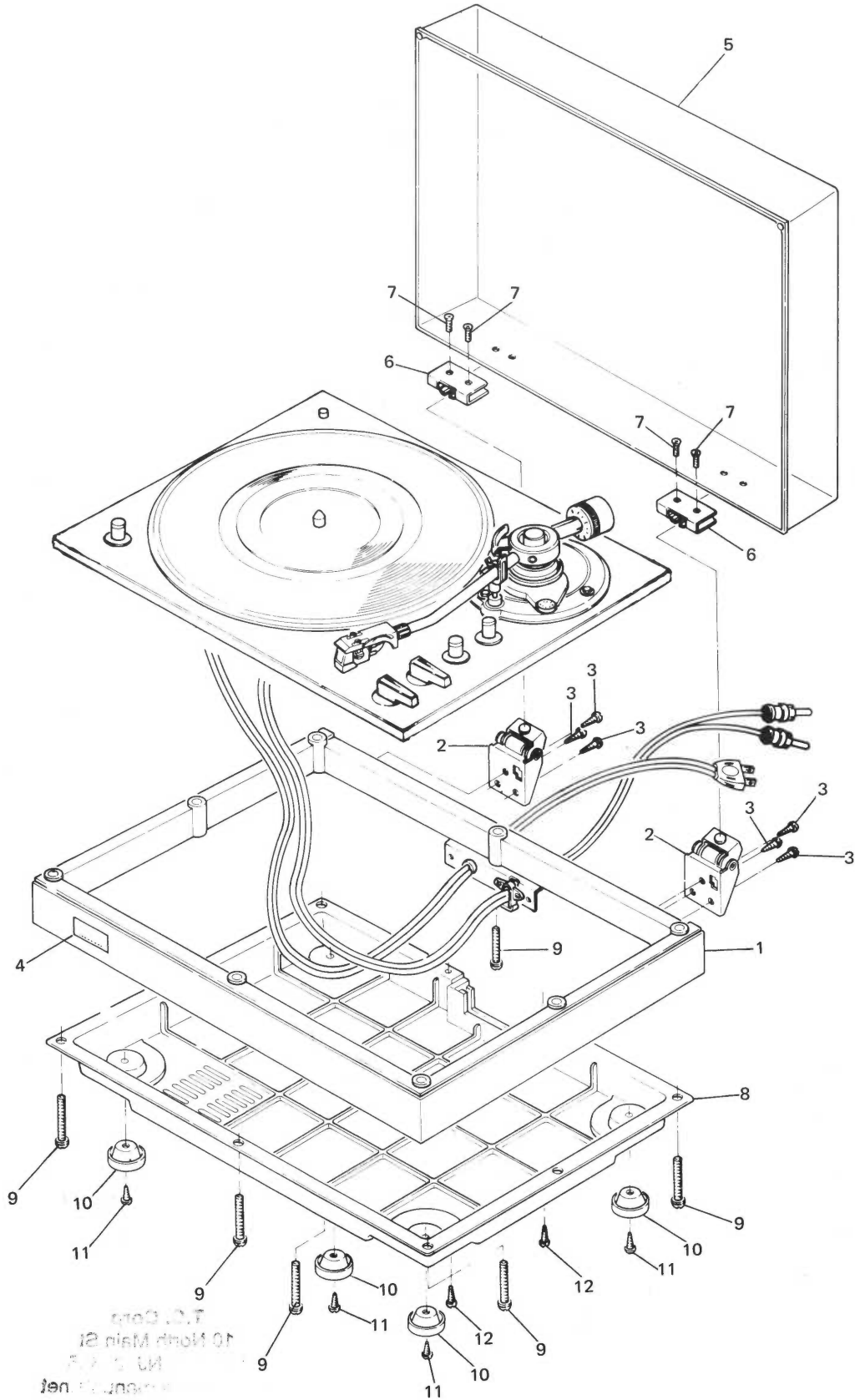

Fig. 27

## 8. List of Parts for Replacement Parts 1

| NO. | PARTS NO.   | PARTS NAME       | REMARKS | QTY |
|-----|-------------|------------------|---------|-----|
| 1   | E10098-018  | Cabinet Ass'y    |         | 1   |
| 2   | E60989-001  | Hinge Ass'y      |         | 2   |
| 3   | SSSB3008M   | Tapping Screw    |         | 6   |
| 4   | QXM2241-001 | Mark             |         | 1   |
| 5   | E10036-002  | Dust Cover Ass'y |         | 1   |
| 6   | E60990-001  | Lock Plate       |         | 2   |
| 7   | SHSP3010RS  | Screw            |         | 4   |
| 8   | E10101-001  | Botoom Board     |         | 1   |
| 9   | LPSP4040MS  | Ass'y Screw      |         | 8   |
| 10  | E60946-002  | Foot Ass'y       |         | 4   |
| 11  | SBSB3008Z   | Tapping Screw    |         | 4   |
| 12  | SBSB3010M   | "                |         | 2   |

T.C. Corp  
 10 North Main St  
 Wharton NJ 07885  
[www.servicemanuals.net](http://www.servicemanuals.net)

# 9. Exploded View of Parts 2

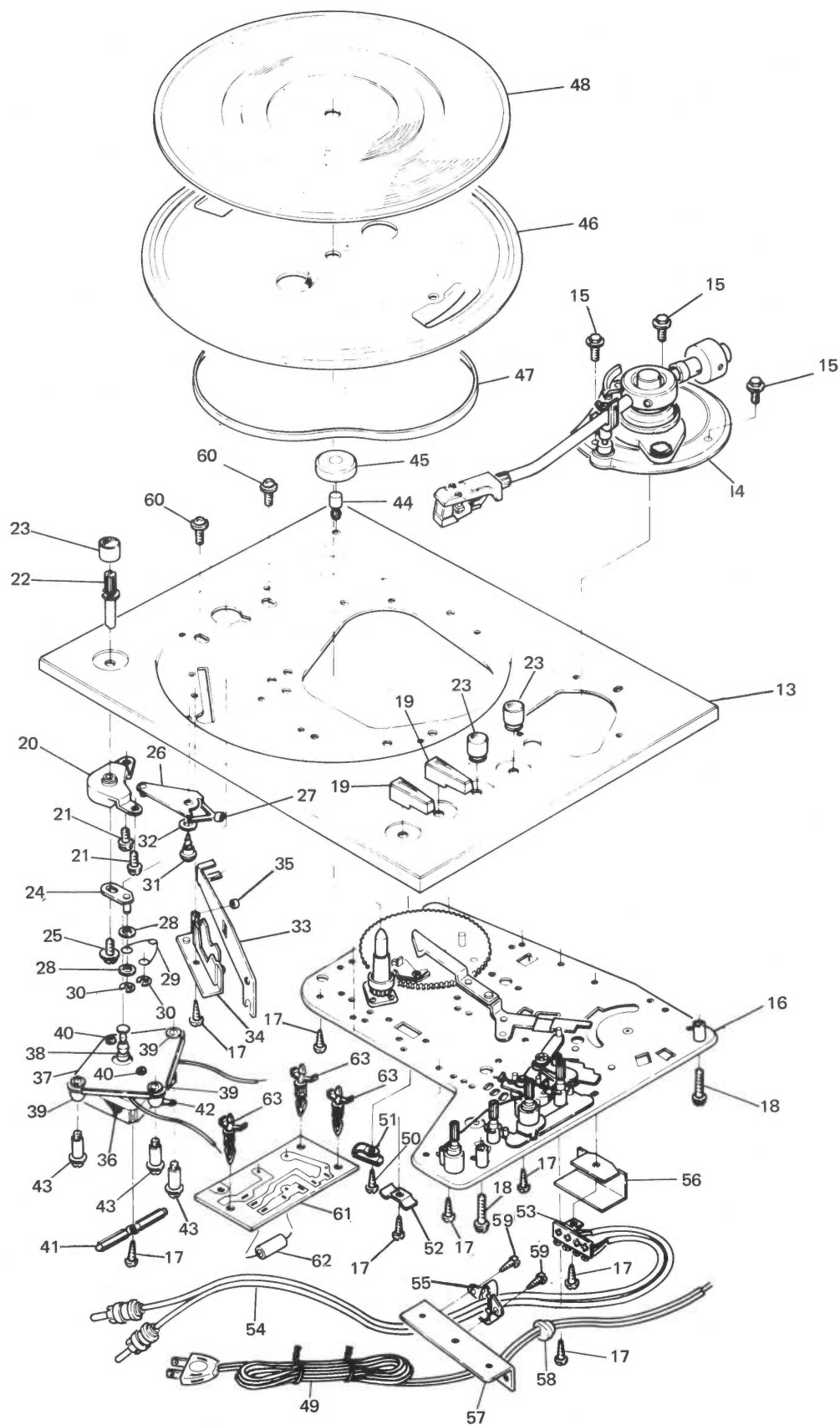

Fig. 28

# 10. Parts for Replacement List of Parts 2

| NO. | PARTS NO.   | PARTS NAME                    | REMARKS          | QTY |
|-----|-------------|-------------------------------|------------------|-----|
| 13  | E10170-001  | Motor Board Ass'y             |                  | 1   |
| 14  | See page 20 | Pickup Ass'y                  | Refer to Table 1 | 1   |
| 15  | E60331-001  | Screw                         |                  | 3   |
| 16  | F3500       | Base Ass'y                    |                  | 1   |
| 17  | SBSB3008Z   | Tapping Screw                 |                  | 8   |
| 18  | LPSP4023ZS  | Ass'y Screw                   |                  | 2   |
| 19  | E34970-001  | Knob                          |                  | 2   |
| 20  | E60340-001  | Knob Base                     |                  | 1   |
| 21  | LPSP4006NS  | Ass'y Screw                   |                  | 2   |
| 22  | E60789-001  | Shaft Ass'y                   |                  | 1   |
| 23  | E61686-001  | Knob                          |                  | 3   |
| 24  | E60343-002  | Lever Ass'y                   |                  | 1   |
| 25  | DPSP3006ZS  | Ass'y Screw                   |                  | 1   |
| 26  | E60346-001  | Lever Ass'y                   |                  | 1   |
| 27  | E60790-002  | Rubber Tube                   |                  | 1   |
| 28  | WNS3000N    | Washer                        |                  | 2   |
| 29  | E60791-001  | Spring                        |                  | 1   |
| 30  | REE2000     | E Ring                        |                  | 2   |
| 31  | G41507      | Tapping Screw                 |                  | 1   |
| 32  | G4517-1     | Washer                        |                  | 1   |
| 33  | E60352-001  | Shifter                       |                  | 1   |
| 34  | E33900-001  | Shifter Holder                |                  | 1   |
| 35  | E60790-001  | Rubber Tube                   |                  | 1   |
| 36  | See page 20 | Motor Ass'y                   | Refer to Table 1 | 1   |
| 37  | E61096-001  | Mounting Plate                |                  | 1   |
| 38  | E60962-001  | 50Hz Pulley                   |                  | 1   |
|     | " -002      | 60Hz "                        |                  | 1   |
| 39  | E49631-003  | Rubber Bushing                |                  | 3   |
| 40  | LPSP3006ZS  | Ass'y Screw                   |                  | 2   |
| 41  | E47203-004  | Wire Clamp                    |                  | 1   |
| 42  | 52396       | Terminal Lug                  |                  | 2   |
| 43  | E49633-001  | Motor Holder                  |                  | 3   |
| 44  | E49629-001  | Adaptor Holder                |                  | 1   |
| 45  | E48820-001  | EP Adaptor                    |                  | 1   |
| 46  | E21908-001  | Platter                       |                  | 1   |
| 47  | G30005      | Belt                          |                  | 1   |
| 48  | E21910-005  | Platter Cover Sheet           |                  | 1   |
| 49  | See page 20 | Power Cord                    | Refer to Table 1 | 1   |
| 50  | SBSB3006Z   | Tapping Screw                 |                  | 1   |
| 51  | E50670-003  | Wire Clamp                    |                  | 1   |
| 52  | G40437      | "                             |                  | 1   |
| 53  | QML1310-041 | Lug Strip Ass'y               |                  | 1   |
| 54  | See page 20 | Signal Cord Ass'y             | Refer to Table 1 | 1   |
| 55  | E33944-001  | Cord Stopper                  |                  | 1   |
| 56  | E60090-001  | Shield Cover                  |                  | 1   |
| 57  | E61277-002  | C'S' Bracket                  |                  | 1   |
| 58  | QHS3876-162 | Cord Stopper                  |                  | 1   |
| 59  | E60133-003  | Special Screw                 |                  | 2   |
| 60  | E49717-001  | Motor Holder                  |                  | 2   |
| 61  | See page 20 | Power Supply P.C. Board Ass'y | Refer to Table 1 | 1   |
| 62  | See page 20 | Capacitor                     | Refer to Table 1 | 1   |
| 63  | E34530-002  | P.C. Board                    |                  | 3   |

# 11. Exploded View of Parts 3

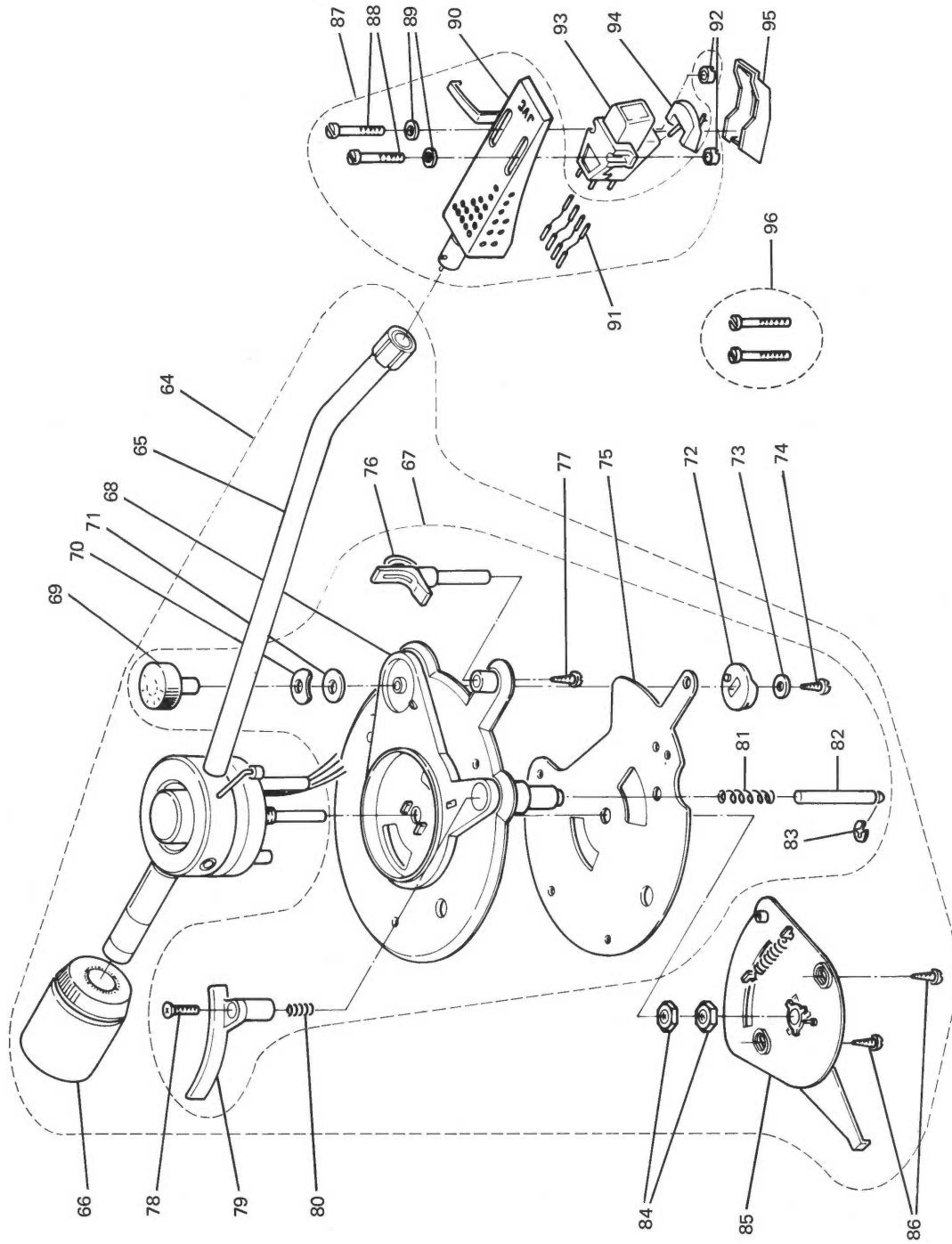

Fig. 29

## 12. List of Parts for Replacement Parts 3

| NO. | PARTS NO.   | PARTS NAME            | REMARKS | QTY |
|-----|-------------|-----------------------|---------|-----|
| 64  | E22325-001  | Tone-arm Ass'y        |         | 1   |
| 65  | *E21985-002 | Arm Ass'y             |         | 1   |
| 66  | E34534-002  | Main Weight Ass'y     |         | 1   |
| 67  | *E22323-001 | Pickup Base Ass'y     |         | 1   |
| 68  | *E22389-001 | Pickup Base Sub Ass'y |         | 1   |
| 69  | *E34962-001 | A.S. Knob             |         | 1   |
| 70  | E49602-002  | Washer                |         | 1   |
| 71  | G4517-1     | Thrust Washer         |         | 1   |
| 72  | E34258-001  | A.S. Cam              |         | 1   |
| 73  | WSS2000Z    | Washer                |         | 1   |
| 74  | SBSB2005Z   | Tapping Screw         |         | 1   |
| 75  | *E34963-001 | Plate                 |         | 1   |
| 76  | E60326-001  | Arm Rest Ass'y        |         | 1   |
| 77  | SBSB2606Z   | Tapping Screw         |         | 1   |
| 78  | SSSP3016MS  | Screw                 |         | 1   |
| 79  | E60475-001  | Elevator Ass'y        |         | 1   |
| 80  | E49649-001  | Spring                |         | 1   |
| 81  | E61194-001  | Spring                |         | 1   |
| 82  | *E49655-004 | Elevator Shaft        |         | 1   |
| 83  | REE3000     | E Ring                |         | 1   |
| 84  | G5053       | Nut                   |         | 1   |
| 85  | *E34241-003 | Arm Lever Ass'y       |         | 1   |
| 86  | SBSB3008Z   | Tapping Screw         |         | 2   |
| 87  | E34991-002  | Head Shell Ass'y      |         | 1   |
| 88  | *E60502-008 | Screw                 | (11mm)  | 2   |
| 89  | Washer      |                       |         | 2   |
| 90  | E34990-002  | Headshell Body Ass'y  |         | 1   |
| 91  | E60501-001  | Wire Ass'y            |         | 1   |
| 92  | E60603-001  | Nut                   |         | 2   |
| 93  | See Page 20 | Cartridge             |         | 1   |
| 94  | See Page 20 | Needle Ass'y          |         | 1   |
| 95  | See Page 20 | Needle Cover          |         | 1   |
| 96  | E60502-002  | Screw                 | (20mm)  | 2   |

\* New Part Item

# 13. Exploded View of Parts 4

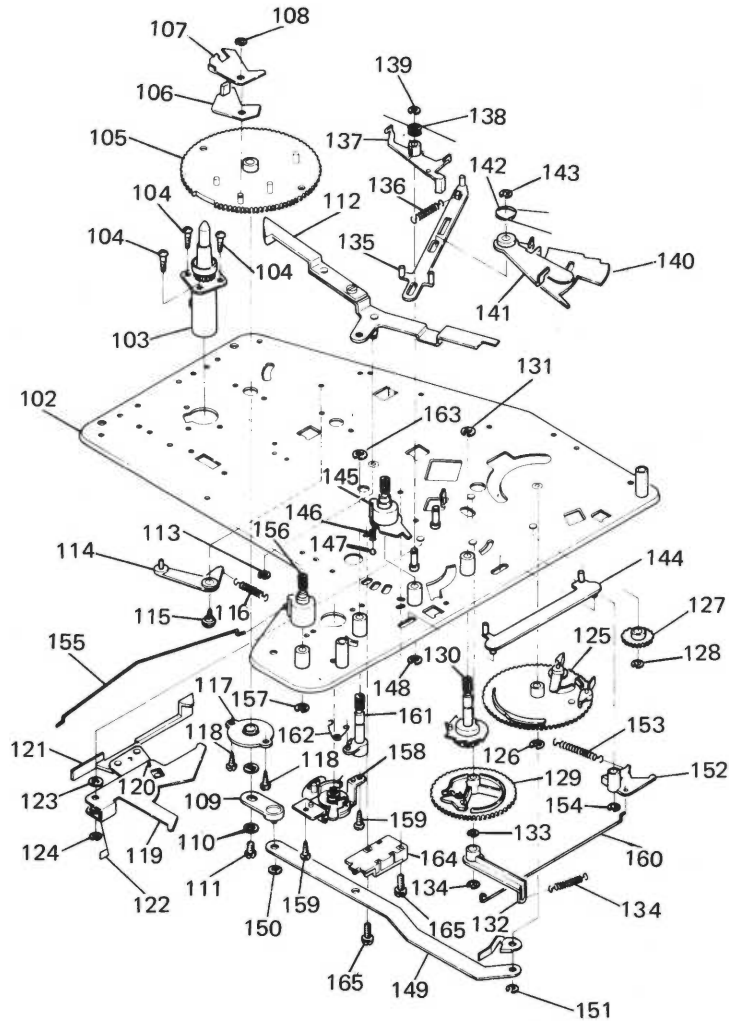

Fig. 30

# 14. List of Parts for Replacement Parts 4

| NO. | PARTS NO.  | PARTS NAME      | REMARKS | QTY |
|-----|------------|-----------------|---------|-----|
| 102 | E10034-001 | Base Sub Ass'y  |         | 1   |
| 103 | E33901-006 | Spindle Ass'y   |         | 1   |
| 104 | SBSB3008Z  | Tapping Screw   |         | 3   |
| 105 | E21913-001 | Main Gear Ass'y |         | 1   |
| 106 | E60380-001 | Lower Trip Pawl |         | 1   |
| 107 | E49627-001 | Engagement Pawl |         | 1   |
| 108 | REE2000    | E Ring          |         | 1   |
| 109 | E60381-001 | Lever           |         | 1   |
| 110 | WNS3000N   | Washer          |         | 1   |
| 111 | LPSP3008ZS | Ass'y Screw     |         | 1   |
| 112 | E34234-001 | Trip Ass'y      |         | 1   |
| 113 | REE3000    | E Ring          |         | 1   |
| 114 | E60383-001 | Stopper         |         | 1   |
| 115 | G41507-2   | Tapping Screw   |         | 1   |



| NO. | PARTS NO.   | PARTS NAME         | REMARKS          | QTY |
|-----|-------------|--------------------|------------------|-----|
| 116 | E60384-001  | Spring             |                  | 1   |
| 117 | E60382-001  | Bushing            |                  | 1   |
| 118 | SBSB3008Z   | Tapping Screw      |                  | 2   |
| 119 | E60395-001  | Reset Plate        |                  | 1   |
| 120 | G41507-2    | Tapping Screw      |                  | 1   |
| 121 | E60394-001  | SW Plate Ass'y     |                  | 1   |
| 122 | E60396-001  | Spring             |                  | 1   |
| 123 | WNS4000N    | Washer             |                  | 1   |
| 124 | REE3000     | E Ring             |                  | 1   |
| 125 | E34236-002  | Driving Gear Ass'y |                  | 1   |
| 126 | REE5000     | E Ring             |                  | 1   |
| 127 | E60400-001  | Idler Gear         |                  | 1   |
| 128 | REE3000     | E Ring             |                  | 1   |
| 129 | E60405-001  | Sub Gear Ass'y     |                  | 1   |
| 130 | E34238-001  | Ratchet Cam Ass'y  |                  | 1   |
| 131 | REE5000     | E Ring             |                  | 1   |
| 132 | E60407-001  | Ratchet Lever      |                  | 1   |
| 133 | REE3000     | E Ring             |                  | 2   |
| 134 | E60489-001  | Spring             |                  | 1   |
| 135 | E60415-001  | Reject Plate       |                  | 1   |
| 136 | E60416-001  | Spring             |                  | 1   |
| 137 | E60417-002  | Reject Lever       |                  | 1   |
| 138 | E60418-001  | Spring             |                  | 1   |
| 139 | REE3000     | E Ring             |                  | 1   |
| 140 | E60425-001  | Index Ass'y        |                  | 1   |
| 141 | E60426-002  | Lever              |                  | 1   |
| 142 | E60427-001  | Spring             |                  | 1   |
| 143 | REE3000     | E Ring             |                  | 1   |
| 144 | E60422-001  | Select Plate       |                  | 1   |
| 145 | E60421-001  | Select Shaft Ass'y |                  | 1   |
| 146 | E60488-001  | Spring             |                  | 1   |
| 147 | G41505-5    | Steel Ball         |                  | 1   |
| 148 | REE5000     | E Ring             |                  | 1   |
| 149 | E34237-001  | Link               |                  | 1   |
| 150 | G4942-4     | Speed Nut          |                  | 1   |
| 151 | REE3000     | E Ring             |                  | 1   |
| 152 | E60390-001  | Elevator Ass'y     |                  | 1   |
| 153 | E49596-001  | Spring             |                  | 1   |
| 154 | REE3000     | E Ring             |                  | 1   |
| 155 | E60428-001  | Rod                |                  | 1   |
| 156 | E60429-001  | Start Shaft Ass'y  |                  | 1   |
| 157 | REE5000     | E Ring             |                  | 1   |
| 158 | E34240-002  | Cueing Ass'y       |                  | 1   |
| 159 | SBSB3006Z   | Tapping Screw      |                  | 2   |
| 160 | E60414-001  | Rod                |                  | 1   |
| 161 | E34239-001  | Cueing Cam Ass'y   |                  | 1   |
| 162 | E49608-002  | Spring             |                  | 1   |
| 163 | REE5000     | E Ring             |                  | 1   |
| 164 | See page 20 | Micro Switch       | Refer to Table 1 | 1   |
| 165 | See page 20 | Screw              | Refer to Table 1 | 2   |
| 166 | See page 20 | Insulation Sheet   | Refer to Table 1 | 1   |

# 15. Final Packing Ass'y

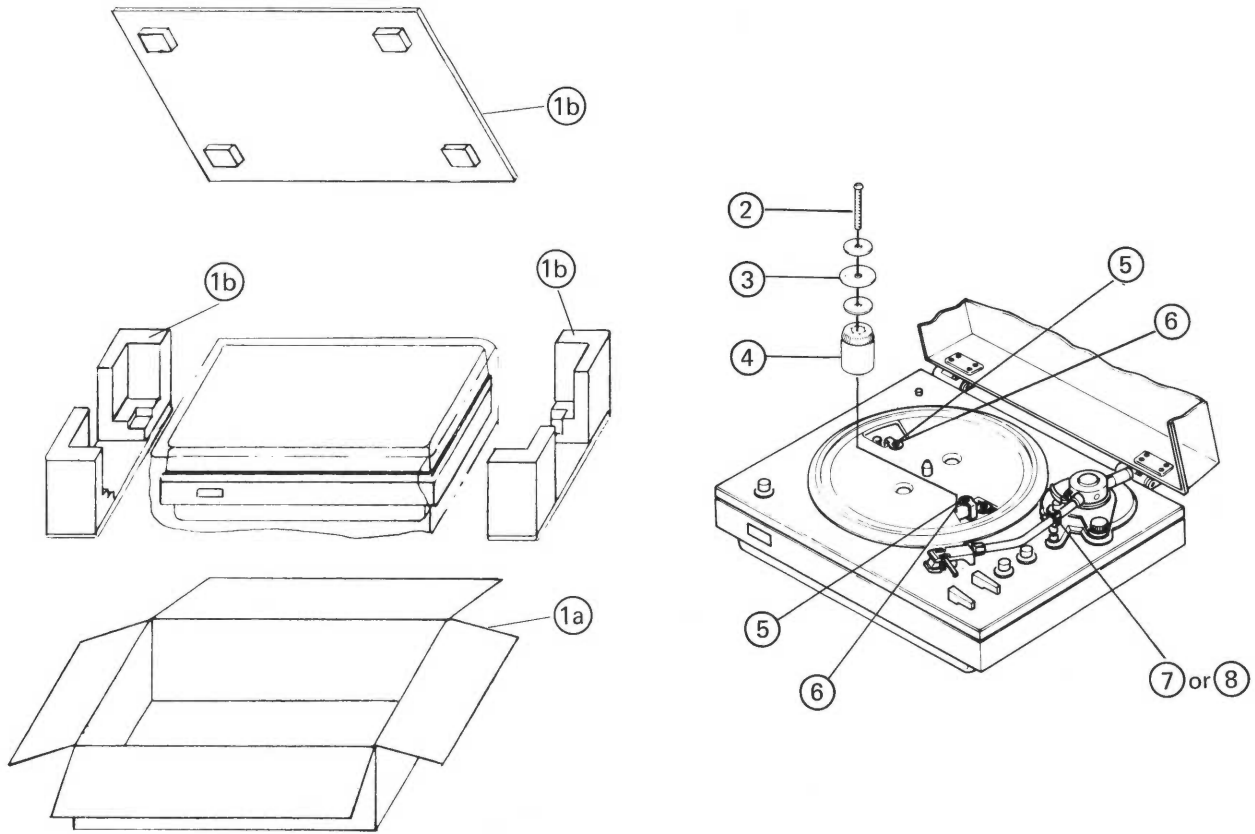

Fig. 31

| NO. | PARTS NO.  | PARTS NAME        | REMARKS                   | QTY |
|-----|------------|-------------------|---------------------------|-----|
| 1a  | JL-F30-PK  | Carton Case       |                           | 1   |
| 1b  | JL-F30-NZ  | Packing Materials | To include pad            | 1   |
| 2   | SPSP4060AS | Screw             | } For Pick-up Main Weight | 1   |
| 3   | Q03091-113 | Washer            |                           | 1   |
| 4   | E60682-001 | Spacer            |                           | 1   |
| 5   | SPSP6050AS | Screw             |                           | 2   |
| 6   | E33939-002 | Platter Protector | } For Platter             | 2   |
| 7   | Q04141-1-K | Wire Clamp        | 50Hz                      | 1   |
| 8   | Q04141-2-K | "                 | 60Hz                      | 1   |

# 16. Accessories

| PARTS NO.         | PARTS NAME                  | REMARKS                              | QTY |
|-------------------|-----------------------------|--------------------------------------|-----|
| See page 20       | Inst. Book                  | Refer to Table 1                     | 1   |
| See page 20       | Inst. Sheet                 | Refer to Table 1                     | 1   |
| See page 20       | Warranty Card               | Refer to Table 1                     | 1   |
| BT-20023          | Service Procedure           | U.S.A. only                          | 1   |
| BT-20024B         | Do It Better                | U.S.A. only                          | 1   |
| E48820-001        | E.P. Adaptor                |                                      | 1   |
| E60962-001 or 002 | Pulley (001 50Hz, 002 60Hz) | U.S. MILITARY MARKET and OTHER AREAS | 1   |
| E64209-003 or 004 | Envelope                    | "                                    | 1   |
| E64207-001        | "                           | "                                    | 1   |

# 17. Schematic Diagram of Model JL-F30

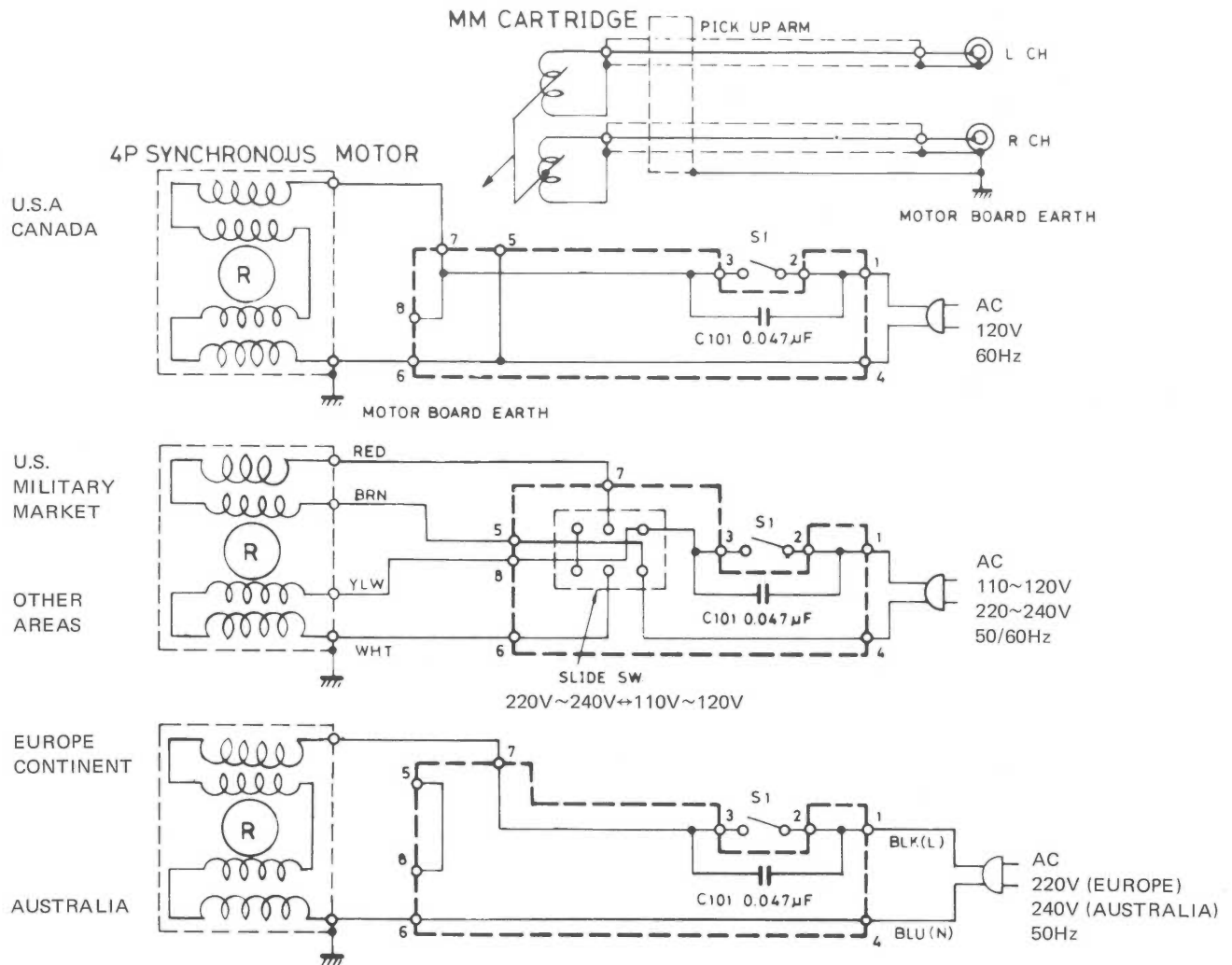

Fig. 32

# 18. Parts List with Specified Numbers for Designated Areas

Table 1 JL-F30

| Page | Item        | PART NAME         | U.S.A.       | CANADA       | AUSTRALIA   | EUROPE      | U.S MILITARY MARKET      | OTHER AREAS                          |
|------|-------------|-------------------|--------------|--------------|-------------|-------------|--------------------------|--------------------------------------|
| 13   | 14          | Pickup Ass'y      | ARM-515      | ARM-515      | MP-168S     | MP-168S     | MP-168SB                 | MP-168S                              |
| "    | 36          | Motor             | M-712L       | M-712L       | M-712M      | M-712M      | M-712C                   | M-712C                               |
| "    | 49          | Power Cord        | QMP1200-244  | QMP1200-244  | QMP2500-200 | QMP3910-244 | QMP1200-244              | QMP1200-244                          |
| "    | 54          | Signal Cord       | E03697-002   | E03697-002   | E03697-002  | E03697-002  | E03697-003               | E03697-002                           |
| "    | 61          | P.C. Board Ass'y  | TSC-60B      | TSC-60G      | TSC-60E     | TSC-60E     | TSC-60C                  | TSC-60C                              |
| "    | 62          | Capacitor         | QFH72BM-473M | QFA72BM-473M | QFZ9017-473 | QFZ9017-473 | QFH53AM-473M             | QFH53AM-473M                         |
| 15   | 93          | Cartridge         | ————         | ————         | MD1025Z     | MD1025Z     | MD1025Z                  | MD1025Z                              |
| "    | 94          | Needle            | ————         | ————         | DT-Z1S      | DT-Z1S      | DT-Z1S                   | DT-Z1S                               |
| "    | 95          | Needle Cover      | ————         | ————         | E34268-001  | E34268-001  | E34268-001               | E34268-001                           |
| 17   | 164         | Micro Switch      | QSM1V01-018  | QSM1V01-018  | QSM1V01-022 | QSM1V01-022 | QSM1V01-018              | QSM1V01-018                          |
| "    | 165         | Screw             | LPSP3014ZS   | LPSP3014ZS   | SPKP3015S   | LPSP3014ZS  | LPSP3014ZS               | LPSP3014ZS                           |
| "    | 166         | Insulation Sheet  | ————         | ————         | E60964-002  | E60964-002  | ————                     | ————                                 |
|      | Accessories | Instruction Book  | E30580-591A  | E30580-591A  | E30580-591A | E30580-591A | E30580-591A              | E30580-591A                          |
|      |             | "                 | ————         | E30580-592A  | ————        | " -592A     | ————                     | ————                                 |
|      |             | "                 | ————         | ————         | ————        | " -593A     | ————                     | ————                                 |
|      |             | Warranty Card     | BT20032      | BT20025      | BT20029     | ————        | BT20014                  | ————                                 |
|      |             | Packing Case      | E22049-140   | E22049-141   | E22049-140  | E22049-140  | E22049-140               | E22049-140                           |
|      |             | Pulley            | E60962-002   | E60962-002   | E60962-001  | E60962-001  | E60962-001<br>E60962-002 | E60962-001(50Hz)<br>E60962-002(60Hz) |
|      |             | Rating Label      | E47330-329   | E49273-009   | E47330-332  | E47330-333  | E47330-330               | E47330-330                           |
|      |             | Service procedure | BT20023      | ————         | ————        | ————        | ————                     | ————                                 |
|      |             | Do It Better      | BT20024B     | ————         | ————        | ————        | ————                     | ————                                 |
|      |             | Caution Tag       | ————         | ————         | ————        | ————        | E64216-002               | E64216-002                           |
|      |             | Inst. Sheet       | ————         | ————         | ————        | ————        | E34705-001               | E34705-001                           |
|      |             | Screw Driver      | ————         | ————         | ————        | ————        | E45557-002               | E45557-002                           |

# 19. Specifications

## MOTOR AND PLATTER

Drive System: Belt drive system  
 Drive Motor: 4-pole synchronous motor  
 Speeds: 33-1/3 and 45 rpm  
 Wow and Flutter: Less than 0.06% (WRMS)  
 Signal to Noise Ratio: Better than 57dB (IEC-B)  
 67dB (DIN-B)  
 Platter: 12-inch (30.9cm) diameter  
 die-cast aluminum alloy

## TO NEARM

Type: Statically-balanced S-shaped tubular arm with JVC developed TH balancing system and with tracking force dial of 0.5 gram steps  
 Effective Arm Length: 220mm  
 Tracking Error: +3° 35', -0° 43'  
 Overhang: 15mm  
 Applicable Tracking Force Range: 0.5 to 3 grams  
 Mountable Cartridge: 14.5~22.5g (Including Headshell)

## CARTRIDGE

(Except U.S.A., Canada and U.K. model)

Type: Moving magnet (MD-1025)  
 Stylus: 0.5mil. diamond for DT-Z1S  
 Optimum Tracking Force: 1.5 to 2.0 grams (DT-Z1S)  
 Output: 3mV (1kHz)  
 Frequency Response: 10 to 25,000Hz (DT-Z1S)  
 Separation: Better than 25dB (1kHz)  
 Load Resistance: 47 to 100k ohms  
 Compliance: 25 x 10<sup>-6</sup> cm/dyne (Static)  
 10 x 10<sup>-6</sup> cm/dyne (Dynamic)

## FEATURES

Tonearm Lifter, Fully Automatic Mechanism, Removable Dust Cover, Anti-skating Device, Repeat Mechanism, etc.

## GENERAL

Dimensions: 46(W) x 36.8(D) x 13(H) cm  
 (18-1/8 x 14-1/2 x 5-1/8 inch)  
 Weight: 7 kg (15.4 lbs.)  
 Power Source: Refer to Table 2  
 Power Consumption: Refer to Table 2

Power Source and Consumption

|                            | Line Voltage & Frequency                   | Power Consumption |
|----------------------------|--|-------------------|
| U.S.A.<br>CANADA           | AC120V, 60Hz                               | 13 watts          |
| EUROPE<br>CONTINENT        | AC220V~, 50Hz                              | 13 watts          |
| U.K.<br>AUSTRALIA          | AC240V~, 50Hz                              | 13 watts          |
| U.S.<br>MILITARY<br>MARKET | AC110~120V/220~240V<br>Selectable, 50/60Hz | 9 watts           |
| OTHER<br>AREAS             | AC110~120V/220~240V<br>Selectable, 50/60Hz | 9 watts           |

Table 2

T.C. Corp  
10 North Main St  
Wharton NJ 07885  
[www.servicemanuals.net](http://www.servicemanuals.net)

**JVC**

RICTOR COMPANY OF JAPAN LIMITED STEREO DIVISION