

TEAC

SERVICE MANUAL

PD-H500i

Compact Disc Player

NOTES

- PC boards shown are viewed from parts side.
- The parts with no reference number or no parts number in the exploded views are not supplied.
- As regards the resistors and capacitors, refer to the circuit diagrams contained in this manual.
- \triangle Parts marked with this sign are safety critical components.
They must be replaced with identical components- refer to the appropriate parts list and ensure exact replacement.
- Parts of [] mark can be used only with the version designated.
[J]: JAPAN [US]: U.S.A. [C]: CANADA
[E]: EUROPE [UK]: U.K. [GE]: GENERAL EXPORT

CONTENTS

SPECIFICATIONS	2
IC PIN FUNCTION	3
WIRING DIAGRAM	13
BLOCK DIAGRAM	15
SCHEMATIC DIAGRAM	17
PRINTED CIRCUIT BOARDS	19
MECHANISM ASS'Y	23
EXPLODED VIEW	27
ELECTRICAL PARTS LIST	30

Specifications

Laser System	: 3-beam laser
Digital Filter	: 8-times oversampling
Frequency Response	: 20-20,000Hz(± 1 dB)
Error Correction Method	: Cross Interleave Reed-Solomon code
S/N Ratio	: More than 100dB (IHF "A" Filter used)
T.H.D	: Less than 0.007(1kHz)
Output Voltage	: 2V RMS

General

Power requirements	: 230V, 50Hz
Power Consumption	: 10W
Dimensions(W×H×D)	: 285×131×292mm
Weight	: 3.9kg

Standard accessories

Remote control cord	1
Signal cord	1

- Improvements may result in specifications and features changing without notice.
- Illustrations may differ slightly from production models.

IC PIN FUNCTION

CXD2529Q (Digital Signal Processor)

NO.	SYMBOL	I/O		DESCRIPTION
1	VDD	-	-	Power supply(+5V).
2	VSS	-	-	GND.
3	LMUT	O	1,0	Left-channel zero detection flag.
4	RMUT	O	1,0	Right-channel zero detection flag.
5	TES2	O	1,0	TEST output pin; normally open.
6	CKOUT	O	1,0	Master clock frequency-divider output. Selects and outputs XTAI×1,× 1/2, × 1/4 or low only.
7	SQCK	I		SQSO readout clock input.
8	SQSO	O	1,0	Sub Q 80-bit serial output.
9	SENS	O	1,0	SENS output to CPU.
10	DATA	I		Serial data input from CPU.
11	XLAT	I		Latch input from CPU. Serial data is latched at the falling edge.
12	CLOK	I		Serial data transfer clock input from CPU.
13	SEIN	I		SENS input from SSP.
14	CNIN	I		Track jump count signal input.
15	DATO	O	1,0	Serial data output to SSP.
16	XLTO	O	1,0	Serial data latch output to SSP. Latched at the falling edge.
17	CLKO	O	1,0	Serial data transfer clock output to SSP.
18	SPOA	I		Microcomputer extended interface (input A).
19	SPOB	I		Microcomputer extended interface (input B).
20	SPOC	I		Microcomputer extended interface (input C).
21	SPOD	I		Microcomputer extended interface (input D).
22	XLON	O	1,0	Microcomputer extended interface (output).
23	FOK	I		Focus OK input. Used for SENS output and the servo auto sequencer
24	VDD	-	-	Power supply (+5V).
25	VSS	-	-	GND.
26	MON	O	1,0	Spindle motor on/off control output.
27	MDP	O	1,Z,0	Spindle motor servo control.
28	MDS	O	1,Z,0	Spindle motor servo control.
29	LOCK	O	1,0	GFS is sampled at 460Hz; when GFS is high, this pin outputs a high signal. If GFS is low eight consecutive samples, this pin outputs low.
30	PWMI	I		Spindle motor external control input.
31	TES0	I		TEST pin; normally GND.
32	TES1	I		TEST pin; normally GND.
33	VPCO2	O	1,Z,0	Wide-band EFM PLL charge pump output. Turned on/off by FCSW of address E.
34	VPCO1	O	1,Z,0	Charge pump output for the wide-band EFM PLL.
35	VCKI	I		VCO2 oscillation input for the wide-band EFM PLL.
36	V16M	O	1,0	VCO2 oscillation output for the wide-band EFM PLL.
37	VCTL	I		VCO2 control voltage input for the wide-band EFM PLL.
38	PCO	O	1,Z,0	Master PLL charge pump output.
39	FILO	I	Analog	Master PLL (slave=digital PLL) filter output.
40	FILI	I		Master PLL filter input.
41	AVSS	-	-	Analog GND.
42	CLTV	I		Master VCO control voltage input.
43	AVDD	-	-	Analog power supply (+5V).
44	RF	I		EFM signal input.
45	BIAS	I		Constant current input of the asymmetry circuit.
46	ASYI	I		Asymmetry comparator voltage input.
47	ASYO	O	1,0	EFM full-swing output (low=VSS, high=VDD)
48	ASYE	I		Low: asymmetry circuit off; high: asymmetry circuit on.
49	WDCK	O	1,0	D/A interface. Word clock = 2fs.
50	LRCK	O	1,0	D/A interface. LR clock output f = fs.
51	LRCKI	I		LR clock input.

NO.	SYMBOL	I/O		DESCRIPTION
52	PCMD	O	1,0	D/A interface. Serial data output (two's complement, MSB first)
53	PCMDI	I		D/A interface. Serial data input (two's complement, MSB first)
54	BCK	O	1,0	D/A interface. Bit clock output.
55	BCKI	I		D/A interface. Bit clock input.
56	Vss	-	-	GND.
57	VDD	-	-	Power supply(+5V).
58	GTOP	O	1,0	GTOP output.
59	XUGF	O	1,0	XUGF output.
60	XPCK	O	1,0	XPLCK output.
61	GFS	O	1,0	GFS output.
62	RFCK	O	1,0	RFCK output.
63	C2PO	O	1,0	C2PO output.
64	XROF	O	1,0	XRAOF output.
65	MNT3	O	1,0	MNT3 output.
66	MNT1	O	1,0	MNT1 output.
67	MNT0	O	1,0	MNT0 output.
68	XTSL	I		Crystal selector input. Low: 16.9344MHz; high: 33.8688MHz.
69	FSTT	O	1,0	2/3 frequency-divider output for pins 89 and 90.
70	C4M	O	1,0	4.2336MHz output. 1/4 frequency-divided VCKI output in CAV-W mode.
71	DOUT	O	1,0	Digital Out output.
72	EMPH	O	1,0	Outputs a high signal when the playback disc has emphasis, and a low signal when there is no emphasis.
73	EMPHI	I		Inputs a high signal when de-emphasis is on, and a low signal when de-emphasis is off.
74	WFCK	O	1,0	WFCK output.
75	SCOR	O	1,0	Outputs a high signal when either subcode sync S0 or S1 is detected.
76	SBSO	O	1,0	Sub P to W serial output.
77	EXCK	I		SBSO readout clock input.
78	Vss	-	-	GND.
79	VDD	-	-	Power supply (+5V).
80	SYSTEM	I		Mute input. Active when high.
81	NC			
82	AVss	-	-	Analog GND.
83	AVDD	-	-	Analog power supply(+5V).
84	AOUT1	O		Left-channel analog output.
85	AIN1	I		Left-channel operational amplifier input.
86	LOUT1	O		Left-channel LINE output.
87	AVss	-	-	Analog GND.
88	XVDD			Power supply for master clock.
89	XTAI	I		Crystal oscillation circuit input. Input the external master clock via this pin.
90	XTAO	O		Crystal oscillation circuit output.
91	XVss			GND for master clock.
92	AVss	-	-	Analog GND.
93	LOUT2	O		Right-channel LINE output.
94	AIN2	I		Right-channel operational amplifier input.
95	AOUT2	O		Right-channel analog output.
96	AVDD	-	-	Analog power supply(+5V).
97	AVss	-	-	Analog GND.
98	NC			
99	NC			
100	XRST	I		System reset. Reset when low.

- Notes)**
- PCMD is an MSB first, two's complement output.
 - GTOP is used to monitor the frame sync protection status. (High: sync protection window released)
 - XUGF is the negative pulse for the frame sync derived from the EFM signal. It is the signal before sync protection.
 - XPLCK is the inverse of the EFM PLL clock. The PLL is designed so that the falling edge of XPLCK and the EFM signal transition point coincide.
 - GFS goes high when the frame sync and the insertion protection timing match.
 - RFCK is derived with the crystal accuracy. This signal has a cycle of 136 μ s (during normal-speed).
 - C2PO represents the data error status.
 - XRAOF is generated when the 16K RAM exceeds the ± 4 F jitter margin.

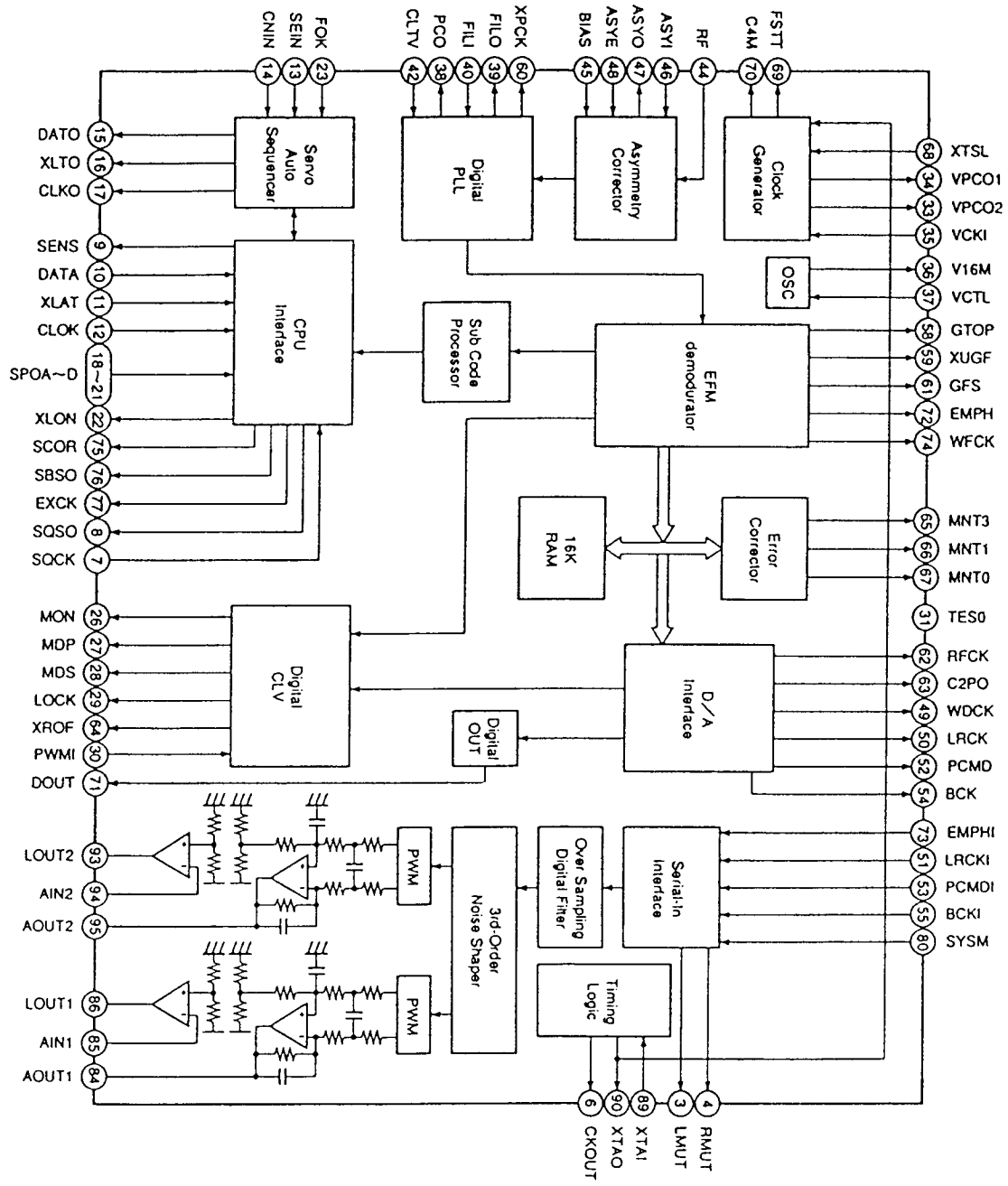

CXA1992BR (RF AMP+Servo signal processor)

NO.	SYMBOL	I/O	DESCRIPTION
1	FEO	O	Focus error amplifier output. Connected internally to the window comparator input for bias adjustment.
2	FEI	I	Focus error input.
3	FDFCT	I	Capacitor connection pin for defect time constant.
4	FGD	I	Ground this pin through a capacitor for cutting the focus servo high-frequency gain.
5	FLB	I	External time constant setting pin for boosting the focus servo low-frequency.
6	FE-O	O	Focus drive output.
13	TA-O	O	Tracking drive output.
16	SL-O	O	Sled drive output.
7	FE-M	I	Focus amplifier inverted input.
8	SRCH	I	External time constant setting pin for generating focus search waveform.
9	TGU	I	External time constant setting pin for switching tracking high-frequency gain.
10	TG2	I	External time constant setting pin for switching tracking high-frequency gain.
11	FSET	I	Peak frequency setting pin for focus and tracking phase compensation amplifier.
12	TA-M	I	Tracking amplifier inverted input.
14	SL-P	I	Sled amplifier non-inverted input.
15	SL-M	I	Sled amplifier inverted input.
17	ISET	I	Connect an external capacitance to set the current which determines the Focus search, Track jump, and Sled kick heights.
18	Vcc	I	Positive power supply.
19	LOCK	I	The sled overrun prevention circuit operates when this pin is low.(no pull-up resistance)
20	CLK	I	Serial data transfer clock input from CPU. (no-pull-up resistance)
21	DATA	I	Serial data input from CPU.(no pull-up resistance)
22	XLT	I	Latch input from CPU.(no pull-up resistance)
23	XRST	I	Reset input; resets at Low.(no pull-up resistance)
24	C. OUT	O	Track number count signal output.
25	SENS1	O	Outputs FZC, DFCT1, TZC, BALH, TGH, FOH, ATSC, and others according to the command from CPU.
26	SENS2	O	Outputs DFCT2, MIRR, BALL, TGL, FOL, and others according to the command from the CPU.
27	FOK	O	Focus OK comparator output.
28	CC2	I	Input for the defect bottom hold output with capacitance coupled.
29	CC1	O	Defect bottom hold output. Connected internally to the interruption comparator input.
30	CB	I	Connection pin for defect bottom hold capacitor.
31	CP	I	Connection pin for MIRR hold capacitor. MIRR comparator non-inverted input.
32	RF-I	I	Input for the RF summing amplifier output with capacitance coupled.
33	RF-O	O	RF summing amplifier output. Eyepattern check point.
34	RF-M	I	RF summing amplifier inverted input. The RF amplifier gain is determined by the resistance connected between this pin and RFO pin.
35	RFTC	I	External time constant setting pin durring RF level control.
36	LD	O	APC amplifier output.
37	PD	I	APC amplifier input.
38	PD1	I	REI-V amplifier inverted input.
39	PD2	I	Connect these pins to the photo diode A+C and B+D pins.
40	FE-BIAS	I	Bias adjustment of focus error amplifier. Leave this pin open for automatic adjustment.
41	F	I	FI-V and EI-V amplifier inverted input.
42	E	I	Connect these pins to photo diode F and E.
43	EI	-	I-V amplifier E gain adjustment. (When not using automatic balance adjustment)
44	VEE	-	Negative power supply.
45	TEO	O	Tracking error amplifier output. E-F signal is output.
46	LPFI	I	Comparator input for balance adjustment. (input from TEO through LPF)
47	TEI	I	Tracking error input.
48	TDFCT	I	Capacitor connection pin for defect time constant.
49	ATSC	I	Window comparator input for ATSC detection.
50	TZC	I	Tracking zero-cross comparator input.
51	VC	O	(VCC+VEE)/2 direct voltage output.
52	FZC	I	Focus zero-cross comparator input.

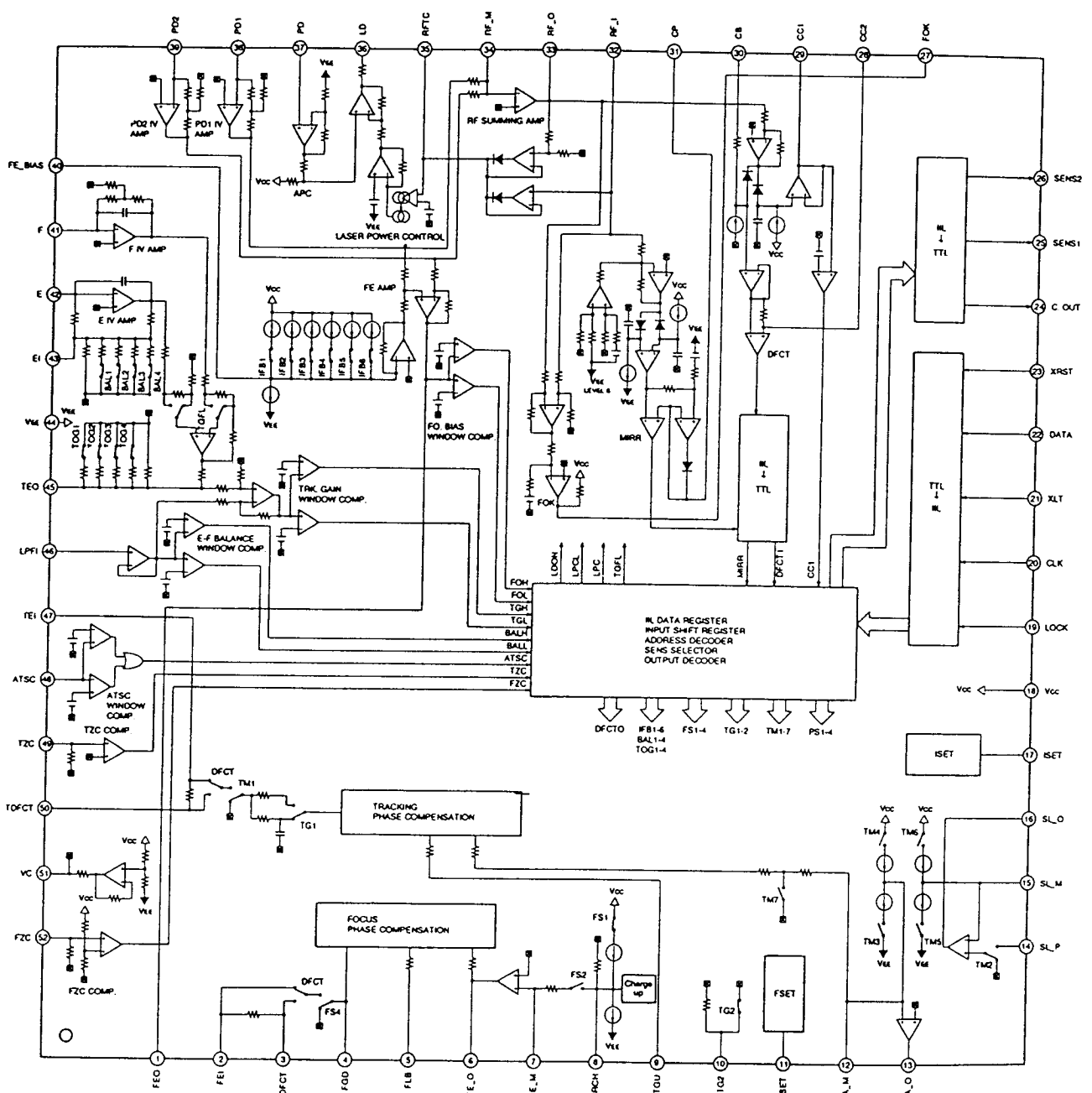

SM5841AP (Digital filter)

NO.	SYMBOL	I/O	DESCRIPTION
1	$\overline{\text{CKLS}}$	IP	Oscillator and input frequency select. 384fs when HIGH, and 256fs when LOW.
2	XTI	I	Oscillator input connection.
3	XTO	O	Oscillator output connection.
4	CKO	O	Oscillator output clock (same frequency as XTI).
5	VSS	—	Ground
6	MDT	IP	Digital attenuator and mode set data .
7	$\overline{\text{MCK}}$	IP	Digital attenuator and mode set clock.
8	MLE	IP	Digital attenuator and mode set latch enable.
9	$\overline{\text{RST}}$	IP	System Reset.
10	DG	O	8fs left/right simultaneous of 4fs left/right alternating de-glitched output.
11	DOR	O	Right-channel data output when in 8fs L/R simultaneous mode, and L/R clock output in 4fs L/R alternating mode.
12	DOL	O	Left-channel data output when in 8fs L/R simultaneous mode, and Left/Right channel data output in L/R alternating mode.
13	WCKO	O	Output word clock.
14	VDD	—	5V supply.
15	BCKO	O	Output bit clock.
16	LRCI	IP	Input data sample rate (fs) clock.
17	BCKI	IP	Input bit clock.
18	DIN	IP	Data input.

BLOCK DIAGRAM

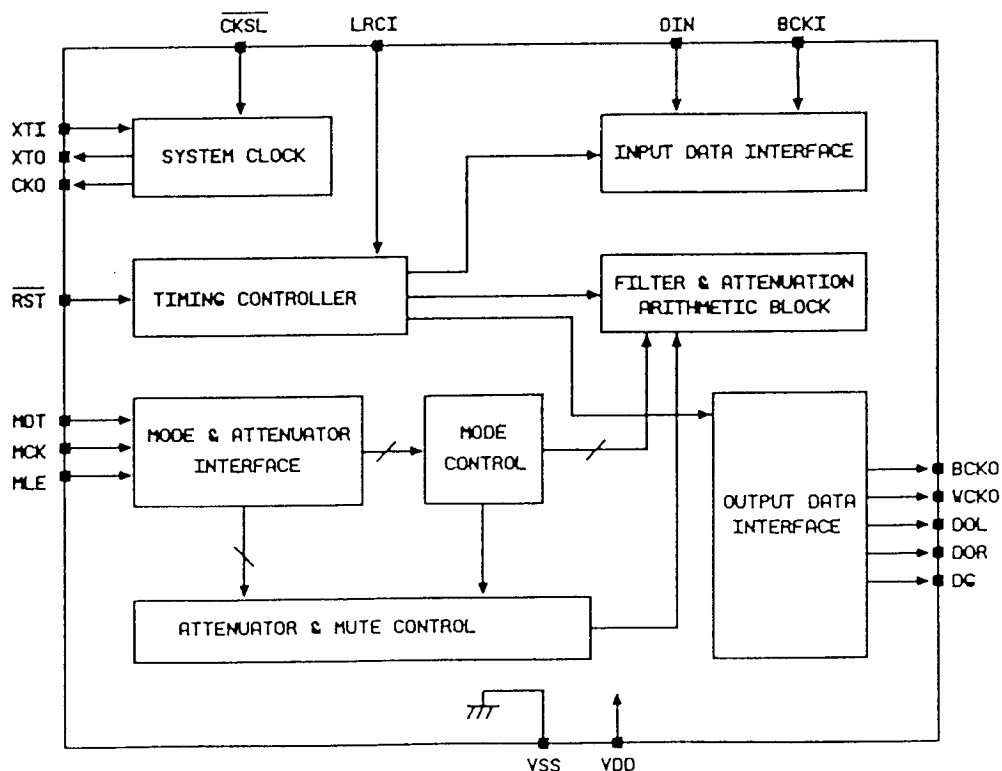

KA9258D (Motor Driver)

NO.	SYMBOL	I/O	DESCRIPTION
1	DO1.1	O	DRIVE OUTPUT
2	DO1.2	O	DRIVE OUTPUT
3	DI1.1	I	DRIVE INPUT
4	DI1.2	I	DRIVE INPUT
5	REG	-	REGULATOR
6	REO	O	REGULATOR OUTPUT
7	MUTE	-	MUTE
8	GND1	-	GROUND
9	DI2.1	I	DRIVE INPUT
10	DI2.2	I	DRIVE INPUT
11	DO2.1	O	DRIVE OUTPUT
12	DO2.2	O	DRIVE OUTPUT
13	GND2	-	GROUND
14	OPOUT	O	OPAMP OUTPUT
15	OPIN (-)	I	OPAMP INPUT(-)
16	OPIN (+)	I	OPAMP INPUT(+)
17	DO3.1	O	DRIVE OUTPUT
18	DO3.2	O	DRIVE OUTPUT
19	DI3.1	I	DRIVE INPUT
20	DI3.2	I	DRIVE INPUT
21	VCC1	-	SUPPLY VOLTAGE
22	VCC2	-	SUPPLY VOLTAGE
23	VREF	-	2.5V BIAS VOLTAGE
24	DI4.1	I	DRIVE INPUT
25	DI4.2	I	DRIVE INPUT
26	DO4.1	O	DRIVE OUTPUT
27	DO4.2	O	DRIVE OUTPUT
28	GND3	-	GROUND

BLOCK DIAGRAM

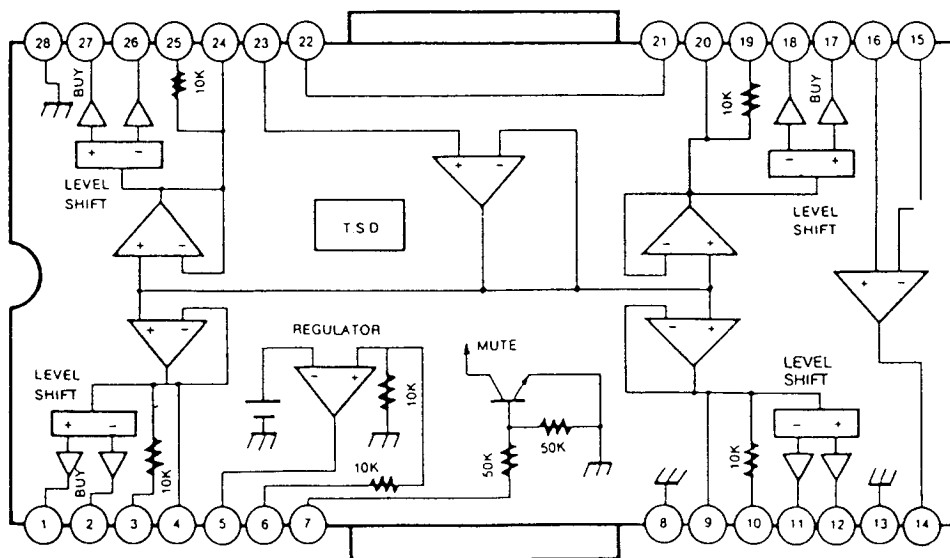

PCM69AP (D/A CONVERTOR)

NO.	SYMBOL	DESCRIPTION
1	VCC	VCC, Analog +5V.
2	Vcom. L-ch	Reference Voltage (3.5V).
3	Lout. L-ch	L-ch current output.
4	Servo DC	Servo filter.
5	REF. DC	Reference filter.
6	Lout. R-ch	R-ch current output.
7	Vcom. R-ch	Reference voltage (3.5V)
8	A-GND	Ground (Analog).
9	D-GND	Ground (Digital).
10	Data, R-ch	R-ch data input.
11	BCK	Bit clock input.
12	SYS CLK	System clock input.
13	WDCK	Word clock input (44.1k).
14	Data, L-ch	L-ch data input.
15	TP1	Select pin for input data format.
16	VDD	VDD, Digital +5V.

BLOCK DIAGRAM

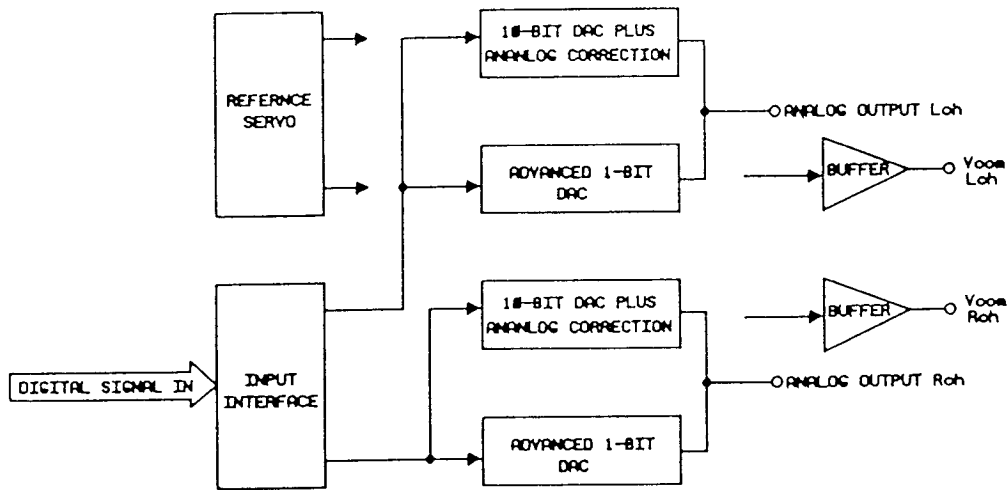

IC70 BVIANAM1232C (μ -COM, TMP87PM78F)

NO.	SYMBOL	I/O	DESCRIPTION
1	VDD	-	+5V POWER SUPPLY PIN
2	F_MOTOR	O	MESHANISM OPEN CONTROL OUTPUT PIN
3	R_MOTOR	O	MESHANISM CLOSE CONTROL OUTPUT PIN
4	/MLE	O	DIGITAL ATTENUATOR AND MODE SET LATCH ENABLE
5	MCK	O	DIGITAL ATTENUATOR AND MODE SET CLOCK
6	MDT	O	DIGITAL ATTENUATOR AND MODE SET DATA
7	REMO SEL	I	REMOTE SELECTOR SWITCH CHECK PIN
8	TEST	I	OPTION(HIGH=AKAI)
9	NC	-	
10	SQCK	O	SUBCODE-Q DATA CLOCK OUTPUT PIN
11	SQSO	I	SUBCODE-Q DATA SERIAL INPUT PIN
12	NC	-	
13	SCOR	I	SUBCODE SYNC SIGNAL (S0+S1) INPUT PIN
14	OP/SW	I	OPEN SWITCH CHECK INPUT PIN
15	CL/SW	I	CLOSE SWITCH CHECK INPUT PIN
16	JOG B	-	SKIP DIAL CONTROL PIN
17	JOG A	-	SKIP DIAL CONTROL PIN
18~21	NC,	-	
22	GND	-	GROUND
23	AGND	-	GROUND
24	VREF	-	+5V POWER SUPPLY PIN
25	VDD	-	+5V POWER SUPPLY PIN
26	NC	-	
27	GND	-	GROUND
28, 29	NC	-	
30	GND	-	GROUND
31	XIN	I	SYSTEM CLOCK OSCILLATION CRYSTAL INTERFACE INPUT PIN
32	XOUT	O	SYSTEM CLOCK OSCILLATION CRYSTAL INTERFACE OUTPUT PIN
33	RESET	I	SYSTEM RESET PIN
34	RE_IN	I	REMOCON DATA INPUT PIN
35	BUS_IN	I	REMOCON DATA INPUT PIN
36	BUS_OUT	O	REMOCON DATA OUTPUT PIN
37	SENS2	I	SSP STATUS INPUT PIN
38	SENS	I	DSP STATUS INPUT PIN
39	COUT	I	TRACK COUNT INPUT PIN
40	MUTE	O	AUDIO MUTE OUTPUT PIN
41	CLOCK	O	CLOCK OUTPUT PIN
42	XLAT	O	LATCH OUTPUT PIN
43	DATA	O	DATA OUTPUT PIN
44	F.OK	I	FOCUS OK INPUT PIN
45	GFS	I	FRAME SYNC STAUS INPUT PIN
46	DSP RESET	O	SYSTEM RESET FROM DSP OUTPUT PIN
47	POWER	O	SYSTM POWER ON/OFF OUTPUT PIN
48	FLT POWER	O	FIP FILAMENT POWER ON, OFF OUTPUT PIN

NO.	SYMBOL	I/O	DESCRIPTION
49	NC	-	
50	-30V	-	FIP VOLTAGE SUPPLY PIN
51	LED	O	STANBY LED ON/OFF OUTPUT PIN
52	LED	O	TIME EDIT LED ON/OFF OUTPUT PIN
53	LED	O	JUST EDIT LED ON/OFF OUTPUT PIN
54	LED	O	MANUAL FADE LED ON/OFF OUTPUT PIN
55	LED	O	AUTO SPACE LED ON/OFF OUTPUT PIN
56~58	NC	-	
59	KS_1	O	KEY SCAN OUTPUT PIN
60	KS_2	O	KEY SCAN OUTPUT PIN
61	KS_3	O	KEY SCAN OUTPUT PIN
62	KS_4	O	KEY SCAN OUTPUT PIN
63	KS_5	O	KEY SCAN OUTPUT PIN
64	KS_6	O	KEY SCAN OUTPUT PIN (NOT USED)
65	KS_7	O	KEY SCAN OUTPUT PIN (NOT USED)
66	KS_8	O	KEY SCAN OUTPUT PIN (NOT USED)
67	P1	O	FIP SEGEMENT SIGNAL OUTPUT PIN
68	P2	O	FIP SEGEMENT SIGNAL OUTPUT PIN
69	P3	O	FIP SEGEMENT SIGNAL OUTPUT PIN
70	P4	O	FIP SEGEMENT SIGNAL OUTPUT PIN
71	P5	O	FIP SEGEMENT SIGNAL OUTPUT PIN
72	P6	O	FIP SEGEMENT SIGNAL OUTPUT PIN
73	P7	O	FIP SEGEMENT SIGNAL OUTPUT PIN
74	P8	O	FIP SEGEMENT SIGNAL OUTPUT PIN
75	P9	O	FIP SEGEMENT SIGNAL OUTPUT PIN
76	P10	O	FIP SEGEMENT SIGNAL OUTPUT PIN
77	P11	O	FIP SEGEMENT SIGNAL OUTPUT PIN
78	P12	O	FIP SEGEMENT SIGNAL OUTPUT PIN
79	P13	O	FIP SEGEMENT SIGNAL OUTPUT PIN
80	P14	O	FIP SEGEMENT SIGNAL OUTPUT PIN
81	P15	O	FIP SEGEMENT SIGNAL OUTPUT PIN
82	P16	O	FIP SEGEMENT SIGNAL OUTPUT PIN
83	1G	O	FIP TIMING SIGNAL OUTPUT PIN
84	2G	O	FIP TIMING SIGNAL OUTPUT PIN
85	3G	O	FIP TIMING SIGNAL OUTPUT PIN
86	4G	O	FIP TIMING SIGNAL OUTPUT PIN
87	5G	O	FIP TIMING SIGNAL OUTPUT PIN
88	6G	O	FIP TIMING SIGNAL OUTPUT PIN
89	7G	O	FIP TIMING SIGNAL OUTPUT PIN
90	8G	O	FIP TIMING SIGNAL OUTPUT PIN
91~94	GND	I	GROUND
95	KI_4	I	KEY SCAN INPUT PIN
96	KI_3	I	KEY SCAN INPUT PIN
97	KI_2	I	KEY SCAN INPUT PIN
98	KI_1	I	KEY SCAN INPUT PIN
99	P17	O	FIP SEGMENT SIGNAL OUTPUT PIN
100	NC	-	

WIRING DIAGRAM

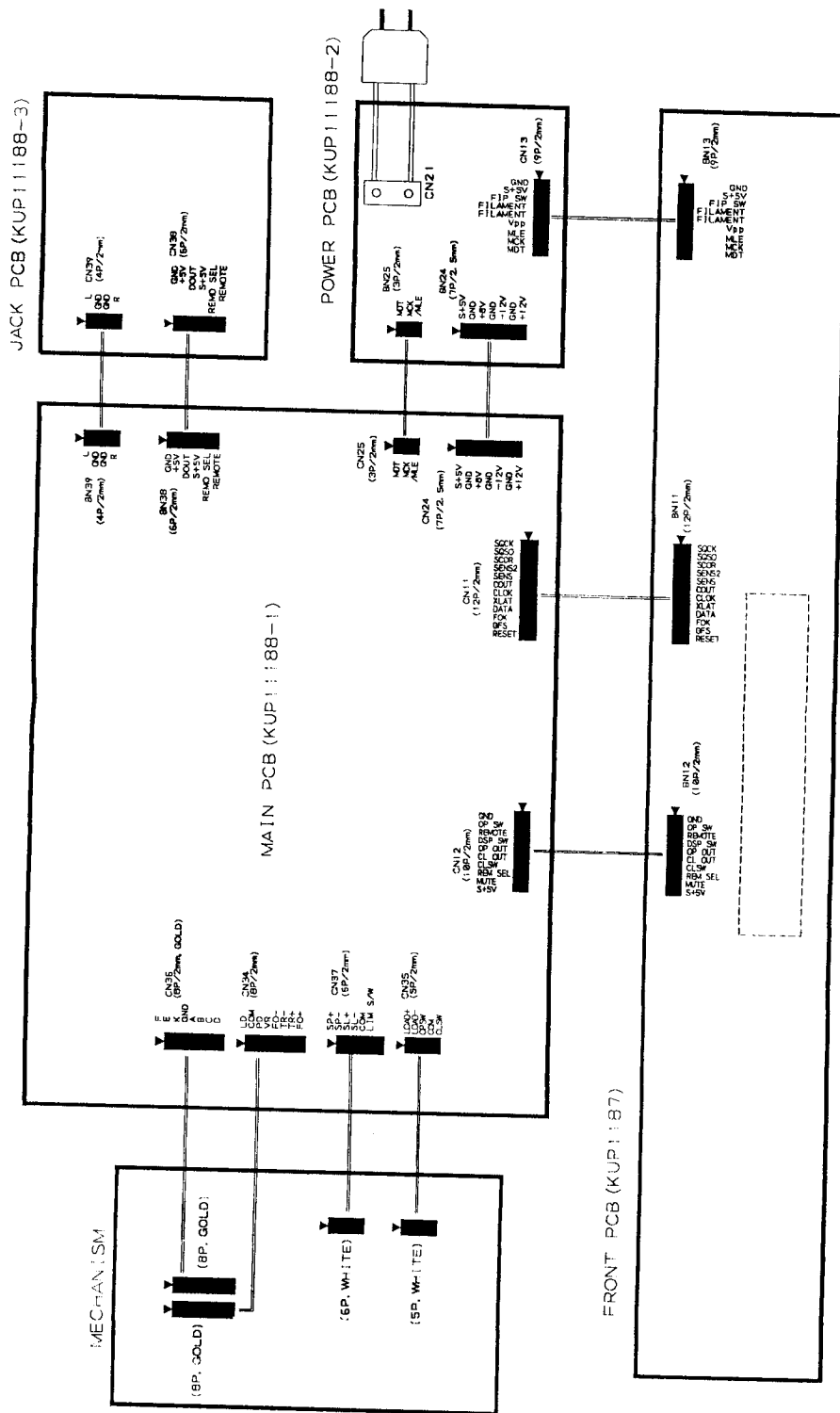

BLOCK DIAGRAM

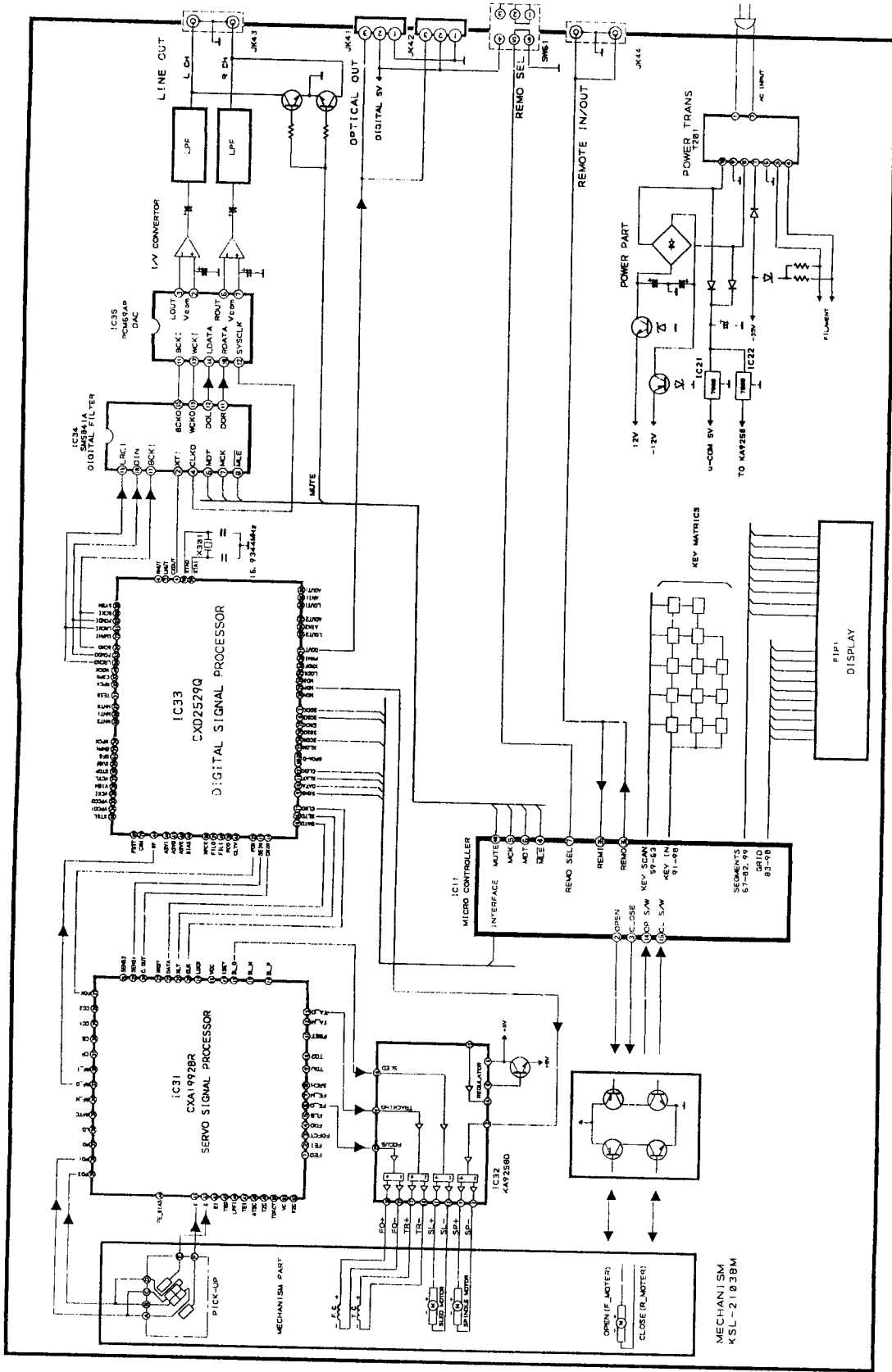

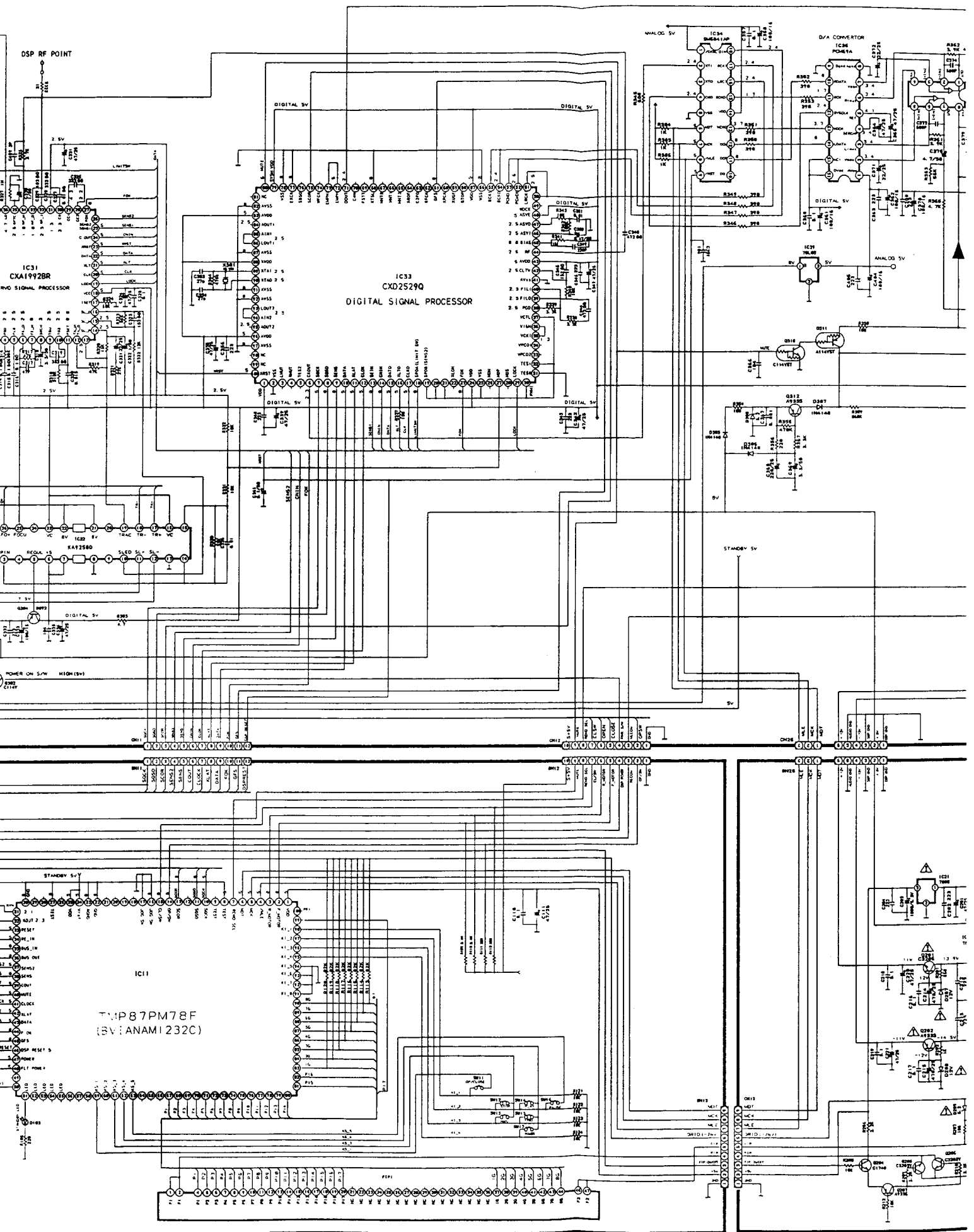

PRINTED CIRCUIT BOARDS

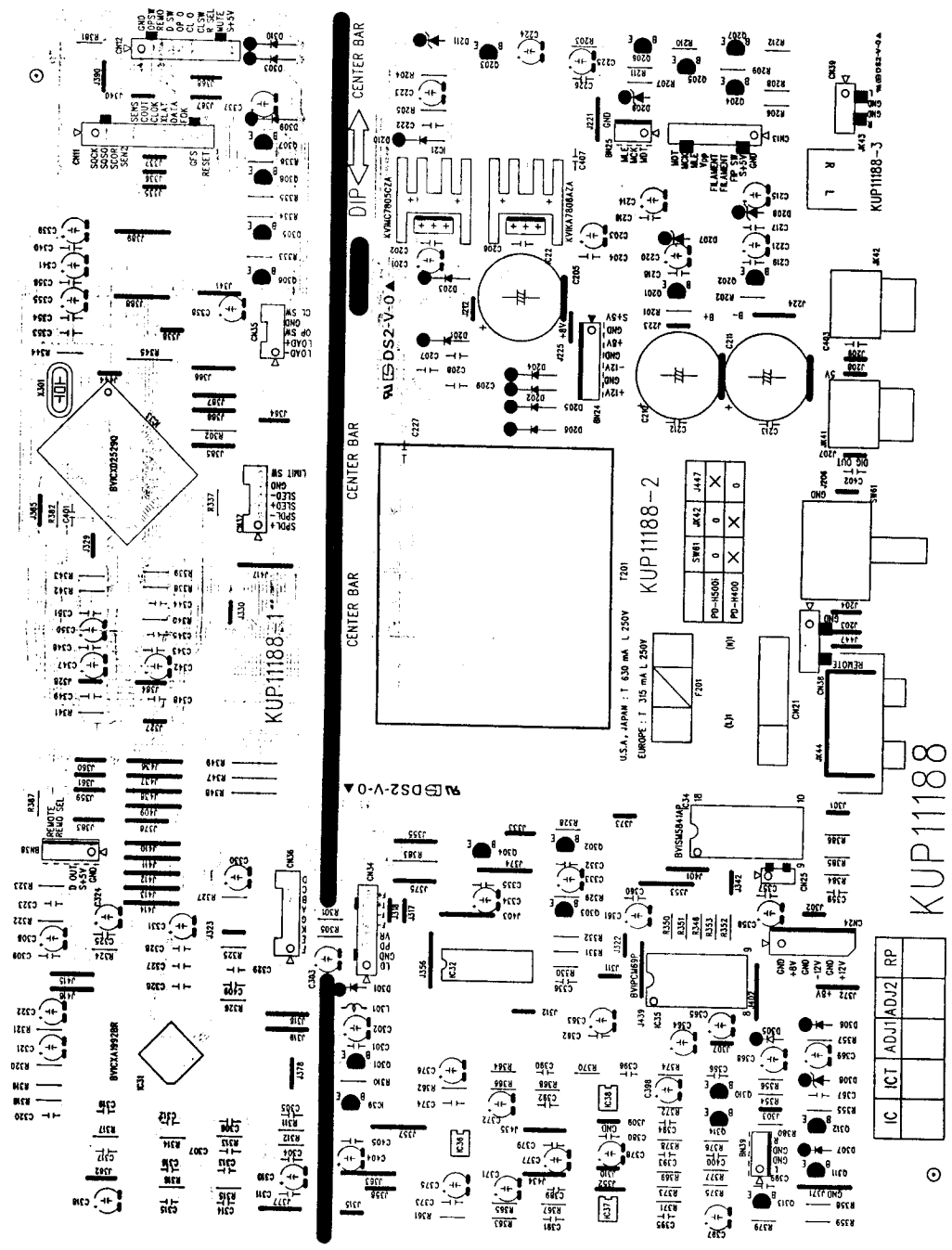

MECHANISM ASS'Y

KSM-2101ABM
Disassembly Drawing

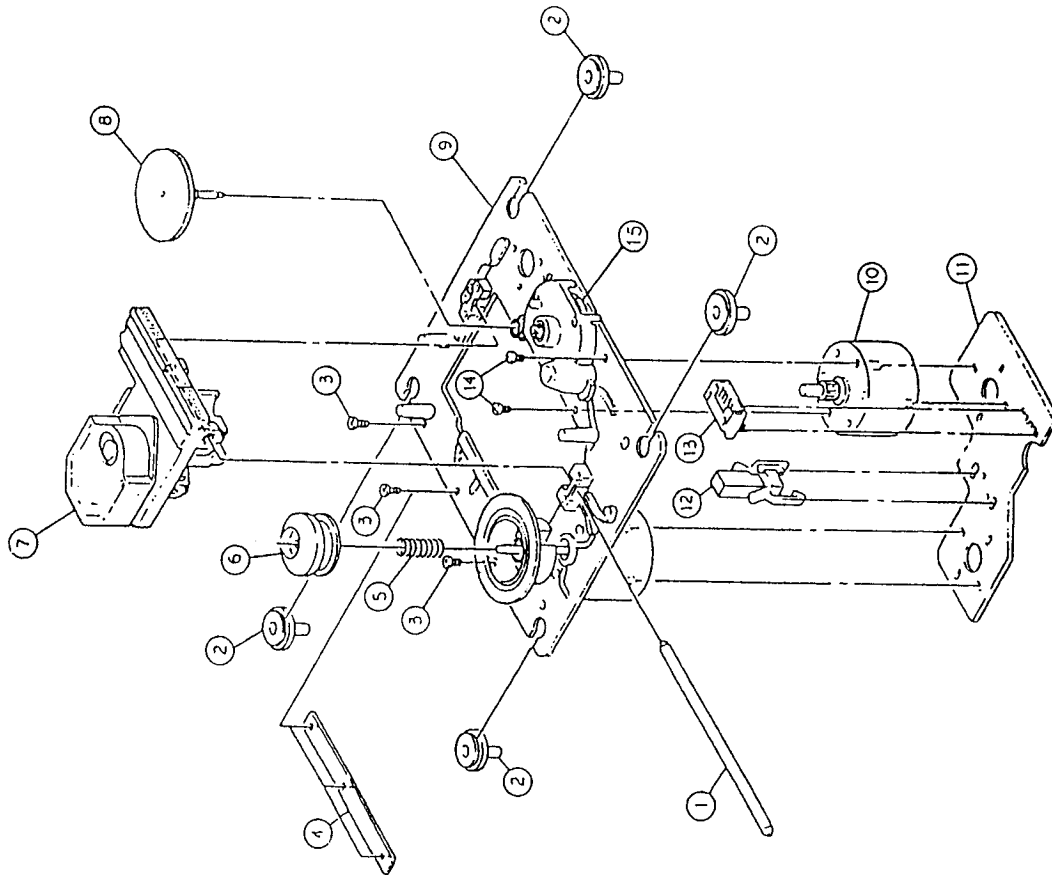

EXPLODED VIEW
REF. NO. PARTS NO.

REF. NO.	PARTS NO.	REMARKS
2-1	9A07269800	SLED SHAFT(S)
2-2	9A06967400	INSULATOR(S)
2-3	9A06967500	SCREW (2X5), TAPPING(S)
2-4	9A06967600	REINFORCEMENT(S)
2-5	9A06967700	SPRING(S), COMPRESSION
2-6	9A06967800	RING (LOX), CENTER
2-7	9A07270000	PIKU UP
2-8	9A07268300	GEAR (AXS)
2-9	9A06968100	CHASSIS ASSY (MB), TT
2-10	9A06968200	GEAR ASSY (MB), MOTOR
2-11	9A07268100	MOTOR PCB (6P)(S)
2-12	9A06968400	SWITCH, LEAF
2-13	9A06968500	PIN, CONNECTOR 6P
2-14	9A06968600	SCREW *P2X3
2-15	9A07269700	GEAR (B)

KSL-2101ABM
Disassembly Drawing

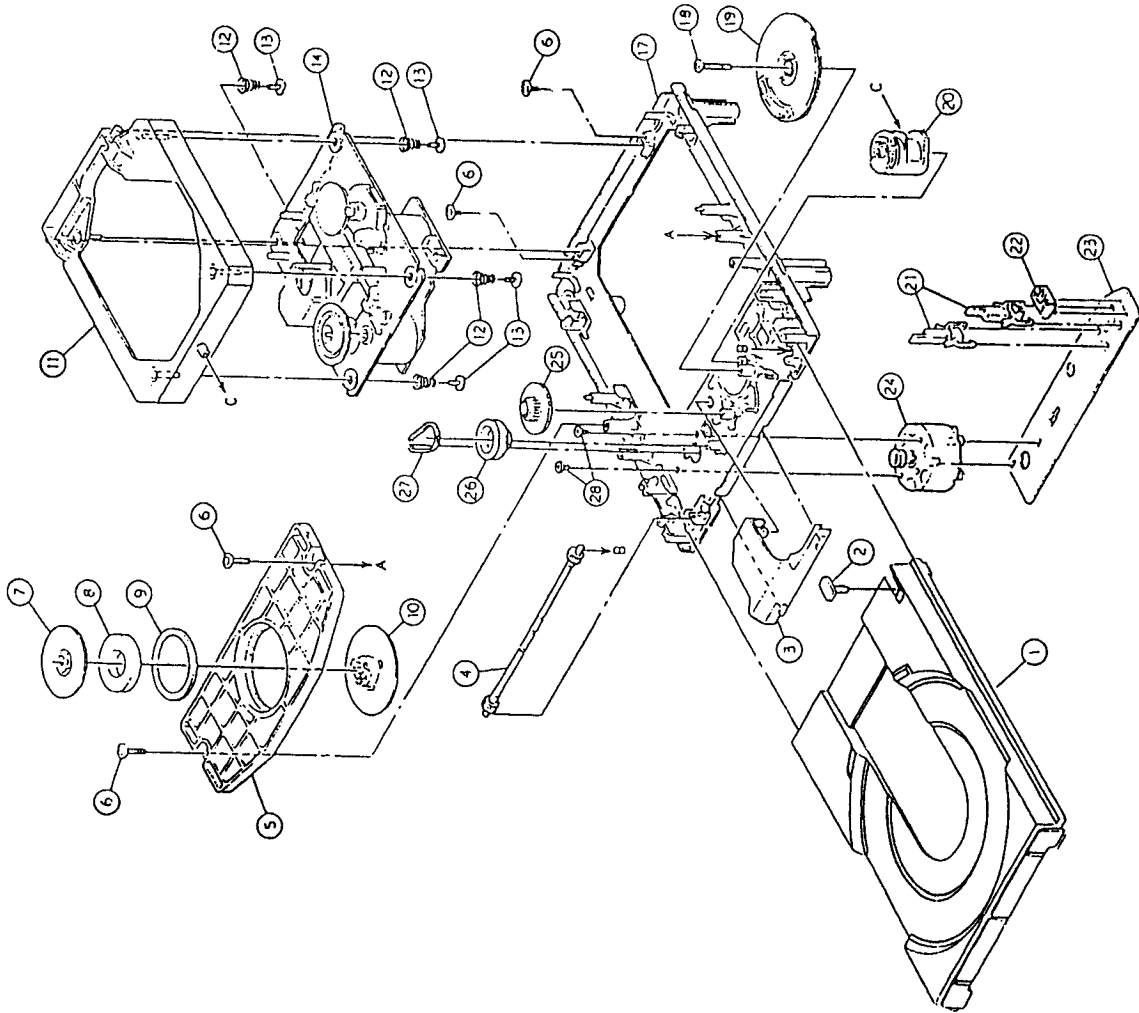

EXPLODED VIEW REF. NO.	PARTS NO.	REMARKS
1-1	9A07269300	TRAY (S)
1-2		VACANT
1-3	9A07268800	GEAR COVER (S)
1-4	9A07268500	TRAY GEAR
1-5	9A07268900	CHUCKING PLATE
1-6	9A07269900	+PTPWH 2.6*7
1-7	9A06965300	YOKE (S), SHUCKING
1-8	9A06965400	MAGNET
1-9	9A07268700	DAMPA
1-10	9A07269200	CHUCKING PULLY
1-11	9A07267600	SUB CHASSIS ASSY (S)
1-12	9A06965800	SPRING (S)
1-13	9A07269900	SCREW
1-14		VACANT
1-15		VACANT
1-16		VACANT
1-17	9A07269400	AUTO SAD MAIN CHSSIS (S)
1-18	9A06966200	SCREW + PTPWH 2.6X16
1-19	9A07269100	DRIVER GEAR (S)
1-20	9A07269000	CONTROL CAM (S)
1-21	9A07268000	LEAF SW
1-22	9A06966600	PIN, CONNECTOR 5P
1-23	9A07267900	LOADING PWB (S)
1-24	9A06966800	MOTOR ASSY, LOADING
1-26	9A07268600	LOADING PULLY
1-28	9A06967200	SCREW +B2.9X2.5

EXPLODED VIEW

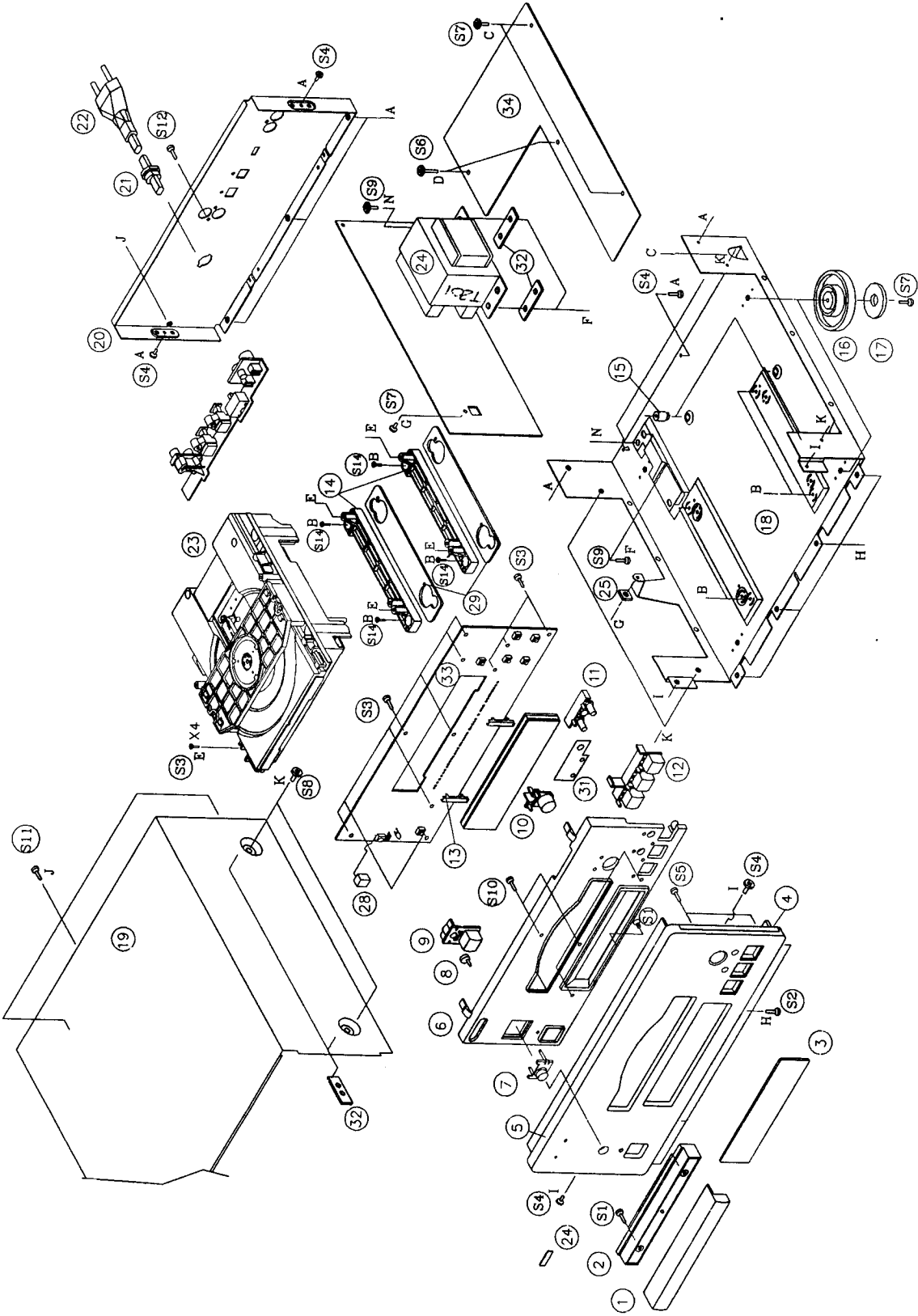

EXPLODED VIEW

REF. NO.	PARTS NO.	REMARKS	
1	9A07264600	ORNAMENT , CD	KGX1A221XC11
2	9A07264300	DOOR , CD	KGR1A152K17
3	9A06240500	WINDOW 1A154Y	KGU1A154Y
4	9A06677600	SIDE BAR	KKM1A062C11
5	9A07270700	PANEL , AL	KKM1A054XC11
6	9A07264500	PANEL , SUB	KGW2A179ZK64
7	9A06863500	WINDOW,SENSOR	KGU2A155
8	9A06227400	INDICATOR,POWER	KGL1A120
9	9A06314500	KNOB , POWER	KBT1A387ZK64
10	9A06314300	KNOB , TACT (OPEN/CLOSE)	KBT1A385YK64
11	9A06239700	KNOB , TACT	KBT1A410C13
12	9A06316000	KNOB , TACT	KBT1A386WK64
13	9A05961600	BRACKET, FLT A4-92-1739	KMD1A209
14	9A07264800	SUPPORT	KHG2A163
15	9A06229100	MOUNT , PCB A4-92-1728	KHE1A023
16	9A06315500	FOOT	KKL1A047ZK63
17	9A06229300	CUSHION, FOOT	KHG1A039Z
18	9A07266100	CHASSIS , MAIN	KUA2A137
19	9A06315900	CABNET, TOP	KKC3B077S21
20	9A07270600	PANEL , REAR	KKF2A127SK59
21	△ 9A01376900	BUSHING, AC CORD HEYCO(SR-	KHR129
22	△ 9A05328100	CORD, POWER [E]	KJA2B019Z
	△ 9A06242000	CORD, POWER [J]	KJA2J026Z
23	9A07263600	CDP MECHANISM ASS'Y	BJDKSL-2101ABM
24	9A06224200	BADGE, TEAC	BGB1A047
25	9A06229400	RUBBER , MECHA	KHG1A115
26		VACANT	
27		VACANT	
28	9A06241300	SUPPORT, SENSOR	KHG1A132
29	9A06241400	RUBBER, SUPPORT	KHG1A135
30		VACANT	
33	9A07270800	CD SUB PCB ASS'Y	KOP11187B
34	9A07270910	CD MAIN PCB ASS'Y [E]	KOP11188B
	9A07270900	CD MAIN PCB ASS'Y [J]	KOP11188D
S1	9A06244200	SCREW KTS3+6J	KTS3+6J
S2	9A01397400	SCREW KTS3+8J	KTS3+8J
S3	9A01377400	SCREW, KTB3+10G	KTB3+10G
S4	9A01535800	SCREW, KTB3+8J	KTB3+8J
S5	9A06229000	SCREW , SPECIAL	KHD1A016
S6	9A06244300	SCREW KTW3+14J	KTW3+14J
S7	9A05339200	SCREW KTW3+8J	KTW3+8J
S8	9A05984300	SCREW KTB4+6FFZ	KTB4+6FFZ
S9	9A06545500	SCREW, SPECIAL	KHD2A018
S10	9A06316300	SCREW KTB+6F	KTB3+6F
S11	9A01377200	SCREW KTB3+8JFZ	KTB3+8JFZ
S12	9A01377300	SCREW, KTB3+10GFZ	KTB3+10GFZ
S13		VACANT	
S14	9A06241200	SCREW , SPECIAL	KHD5A009
	△ 9A06239400	FUSE, 2C0630TLE [J]	KBA2C0630TLE
	△ 9A07270200	FUSE [E]	KBA2C0315TLU

INCLUDED ACCESSORIES

REF. NO.	PARTS NO.	REMARKS	
	9A05935900	CORD, PIN	KJS4M014Y
	9A05936000	CORD, PIN	KJS4N001Y
	9A07124600	OWNER'S MANUAL, E/F/G/I/S PD-H500I [E]	KQX1A476Z
	9A07125600	OWNER'S MANUAL (J) [J]	KQX1A491Z

■ Resistor and Capacitor

- Notes :
- Part numbers are indicated for most mechanical parts.
Please use this part number for parts order.
 - **IMPORTANT SAFETY NOTICE.**
Components identified by \triangle mark have special characteristics important for safety.
When replacing any of these components, use only manufacture's specified parts.
 - The unit of resistance is OHM(Ω)
K=1000(Ω), M=1000(K Ω)
 - The unit of capacitance is MICROFARAD(μ F).
P=10⁻⁶ μ F

■ Numbering System of Resistor

Example

$\frac{\text{KRD}}{\text{Type}}$ $\frac{25}{\text{Wattage}}$ $\frac{\text{F}}{\text{Shape}}$ $\frac{\text{J}}{\text{Tolerance}}$ $\frac{101}{\text{Value}}$

Resistor Type	Wattage	Tolerance
KRD:Carbon	20:1/5W	F:±1%
KRG:Metal Oxide	25:1/4W	J:±5%
	50:1/2W	K:±10%
KRF:Metal Cement	1:1W	
	2:2W	
	3:3W	

■ Numbering System of Capacitor

Example

$\frac{\text{KCKT}}{\text{Type}}$ $\frac{1\text{H}}{\text{Voltage}}$ $\frac{101}{\text{Value}}$ $\frac{\text{K}}{\text{Tolerance}}$ $\frac{\text{B}}{\text{Peculiarity}}$

Capacitor Type	Voltage		Tolerance
	ECEA Type	Other	
KCB: Ceramic	OJ:6.3V	1H:50V DC	C:±0.25pF
KCC: Ceramic	1A:10V	1:125V DC	G:±2%
KCK: Ceramic	1C:16V	KC:400V AC	J:±5%
KCFR: Semiconductor	1E:25V		K:±10%
KCQI: Polyester	1H:50V		Z: +80%, -20%
KCQP: Polypropylene	1V:35V		
KCQS: Polystyrol			

CD MAIN PCB ASS'Y
REF. NO. PARTS NO.

REF. NO.	PARTS NO.	REMARKS
	9A07265600	CD MAIN PCB ASS'Y
	9A07266300	CD MAIN PCB
	9A05341500	IC, KA7805-ABTU
	9A05218300	IC,KA7808-ABTU
	9A05328200	HOLDER,FUSE KJCF5S
C205	△ 9A06246900	CAP, ELECT KCEA1EH332E
C210.211	△ 9A06240300	CAP, ELECT KCEA1EAH102E
C214.215	△ 9A07264000	CAP, ELECT KCEA1EAHS471E
D201-204	△ 9A05194700	DIODE,1N4003ST
D207.208	△ 9A05359600	DIODE,ZENER MTZJ12BT
D209	△ 9A06236200	DIODE,ZENER MTZJ6.2BT
D210	△ 9A05194700	DIODE,1N4003ST
D211	△ 9A05193700	DIODE,ZENER MTZJ24BT
D301	△ 9A01390500	DIODE,1N4148MT
D303	△ 9A05194700	DIODE,1N4003ST
D305-307	9A01390500	DIODE,1N4148MT
D308	△ 9A06236200	DIODE,ZENER MTZJ6.2BT
D309.310	△ 9A05194700	DIODE,1N4003ST
IC31	9A06867800	I.C, SSP CXA1992BR
IC32	9A05218500	IC,KA9258D
IC33	9A06867900	I.C, DSP CXD2529Q
IC34	9A07263800	I.C, DIGITAL FILTER
IC35	9A07263700	I.C BVIPCM69P
IC36-38	9A06871800	I.C KA4558D
IC39	△ 9A06883400	I.C KA78L05AZTA
JK41	9A06239100	MODULE, OPTICAL
JK43	9A06242100	JACK, LINE IN TERMINAL
JK44	9A06242200	JACK, BOARD
L301	9A05356900	COIL, AXAIL 10UH,K
Q201	9A06871900	TR,KTC3205YT
Q202	△ 9A05911600	TR,2SA933SR
Q203	△ 9A05196700	TR,KSA916-Y-SHTA
Q204	9A05939500	TR,2SC1740SR
Q205.206	△ 9A05197400	TR,KTC3203YT
Q207	9A05911600	TR,2SA933SR
Q301	9A05895900	TR,KTA1266YT
Q302	△ 9A05196500	TR,DTC114YST
Q303.304	△ 9A05219100	TR,2SB892T
Q305.306	△ 9A06871900	TR,KTC3205YT
Q307.308	△ 9A05197200	TR,KTA1271YT
Q310	△ 9A05196500	TR,DTC114YST
Q311	△ 9A05196400	TR,DTA114YST
Q312	9A05911600	TR,2SA933SR
Q313.314	△ 9A05197500	TR,KTD1302T
T201	△ 9A07265300	TRANS, POWER
X301	9A05193100	CRYSTAL, 16934A120C
		KOP11188G
		KUP11188Z
		KVIMC7805C
		KVIKA7808A
		KJCF5S
		KCEA1EH332E
		KCEA1EAH102E
		KCEA1EAHS471E
		KVD1N4003ST
		KVDMTZJ12BT
		KVDMTZJ6.2BT
		KVD1N4003ST
		KVDMTZJ24BT
		KVD1N4148MT
		KVD1N4003ST
		KVD1N4148MT
		KVD1N4003ST
		KVD1N4148MT
		KVD1N4003ST
		KVD1N4148MT
		KVD1N4003ST
		KVD1N4148MT
		KVICXA1992BR
		KVIKA9258D
		BVICXD2529Q
		BVISM5841AP
		BVIPCM69P
		KVIKA4558D
		BVICXD2529Q
		BVISM5841AP
		BVIPCM69P
		KVIKA4558D
		KVIKA78L05A
		BJS9L001Z
		KJJ4N005Y
		KJJ4N016Z
		KLQ02C100KT
		KVTKTC3205YT
		KVT2SA933SRT
		KVTKSA916YT
		KVT2SC1740SRT
		KVTKTC3203YT
		KVT2SA933SRT
		KVTKTA1266YT
		KVTDTC114YST
		BVT2SB892T
		KVTKTC3205YT
		KVTKTA1271YT
		KVTDTC114YST
		KVTDTA114YST
		KVT2SA933SRT
		KVTKTD1302T
		KLT5M016ZE
		KOX16934A120C

CD SUB PCB ASS'Y
REF. NO. PARTS NO.

REF. NO.	PARTS NO.	REMARKS
	9A07265500	CD SUB PCB ASS'Y
	9A05961600	BRACKET, FLT A4-92-1739
	9A07266200	CD SUB PCB
C108	△ 9A06904800	CAP,ELECT ACKS470T
D101.102	9A01390500	DIODE,1N4148MT
D103	9A05195000	LED,RED SLR342VCF02
FIP1	9A07313300	F.I.P. SVA08MS14
IC11	9A06867700	I.C,MICOM ANAM1232C
Q101.103	9A05196500	TR,DTC114YST
Q102	9A05196400	TR,DTA114YST
SW11-17	9A06671200	SW.TACT EVQ21505R
X101	9A05193000	CRYSTAL, 08000E160C
		KOP11187C
		KMD1A209
		KUP11187Z
		KCEA1CKS470T
		KVD1N4148MT
		KVD342VCF02T085
		KFLSVA08MS14
		BVIANAM1232C
		KVTDTC114YST
		KVTDTA114YST
		BST1A014ZT
		KOX08000E160C