

Service Manual

MB-1s MB-2s MB-3s

MusicBank CD Player

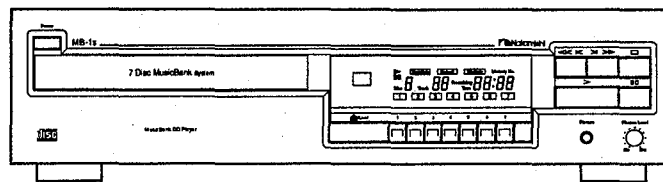

 Nakamichi

CONTENTS

1. General	1
2. Removal Procedures	4
2.1. Mechanism Ass'y	4
2.2. Mechanism Top Cover	4
2.3. Drawing the Tray Ass'y	5
2.4. Laser Pickup	5
2.5. Tray Ass'y	5
2.6. Drive Unit Section	6
2.7. Side Chassis R Section	7
2.8. Side Chassis L	8
2.9. Stocker Ass'y and Main Chassis Section	8
3. Mechanical Adjustments	9
3.1. Gear Positioning in the Side Chassis R Section	9
3.2. Positioning the Tray Ass'y	9
3.3. Lubrication	10
4. Measurement Instruments and Jigs	11
5. Parts Location for Electrical Adjustment	12
6. Electrical Adjustments	13
7. Mechanism Ass'y and Parts List	17
7.1. Synthesis	17
7.2. Front Escutcheon Section (A01)	19
7.3. Mechanism Ass'y (A02)	20
7.4. Side Chassis R Section (B01)	21
7.5. Main Chassis Section (B02)	22
7.6. Drive Unit Section (B03)	23
8. Mounting Diagrams and Parts List	24
8.1. Main P.C.B. Ass'y	24
8.2. Transformer P.C.B. Ass'y	25
8.3. Power Switch P.C.B. Ass'y	25
8.4. Key P.C.B. Ass'y	25
8.5. Display P.C.B. Ass'y	25
8.6. Headphone P.C.B. Ass'y (MB-1s and -2s)	25
8.7. DAC P.C.B. Ass'y (MB-1s)	25
9. IC Block Diagrams	32
10. Block Diagrams	35
11. Wiring Diagrams	37
12. Schematic Diagram (DAC Circuit [MB-1s])	40

Specifications

Schematic Diagram (See attached sheet except for DAC circuit [MB-1s].)

1. GENERAL

1.1. Product Code

V328 (MB-1s)
V329 (MB-2s)
V330 (MB-3s)

1.2. Destinations

USA, CAN, EP, UK, AUS, OTR, JPN

Abbreviations

USA — U.S.A.
CAN — Canada
EP — Europe
UK — United Kingdom
AUS — Australia
OTR — Other
JPN — Japan

1.3. Cautions/Warnings

(1) Product Safety Notice

Parts marked with the symbol  in the schematic diagram have critical characteristics.

Use ONLY replacement parts recommended by the manufacturer. It is recommended that the unit be operated from a suitable DC supply or batteries during initial check-out procedures.

(2) Leakage Current Check/Resistance Check

Before returning the unit to the customer, make sure you make either (1) a leakage current check or (2) a line to chassis resistance check. If the leakage current exceeds 0.5 milliamp, or if the resistance from chassis to either side of the power cord is less than 240 k ohms, the unit is defective.

WARNING — DO NOT return the unit to the customer until the problem is located and corrected.

(3) Protection of Eyes from Laser Beam

To protect eyes from invisible laser beam during servicing,
DO NOT LOOK AT THE LASER BEAM.

• Laser Diode Properties

Material: GaAlAs
Laser output: 0.5mW Max.
Wavelength: 790 ± 25 nm
Emission duration: Continuous

(4) Laser Caution CAUTION

Adjusting the knobs, switches, and controls, etc. or taking actions not specified herein may result in a harmful emission of laser beams. This Compact Disc Player must be adjusted and repaired only by qualified service personnel.

OBSERVERA!

Sådana inställningar av rattarna, omkopplarna eller övriga kontrollknappar som inte är beskrivna i bruksanvisningen kan resultera i farlig laserstrålning. Justering eller reparation av denna kompaktskivspelare skall endast utföras av kvalificerad servicepersonal.

OBS!

Indstilling af knapper, omskiftere og øvrige kontrolknapper, som ikke følger den i brugsanvisningen beskrevne måde, kan resultere i farlig laserudstråling. Justering eller reparation af denne CD-afspiller må kun udføres af kvalificeret servicepersonale.

OBS!

Justering av ratt, brytere og kontroller andre enn de som er beskrevet her, kan resultere i farlig laserbestråling. Justering eller reparasjon av denne kompaktdiskspilleren må bare utføres av kvalifiserte fagfolk.

HUOMAUTUS

Jos nuppeja, kytkimiä ja säätimiä ym, säädetään tai laitetta käytetään toisella tavalla kuin on selostettu, tuloksena saattaa olla vaarallista lasersäteiden vuotoa. CD-soittimen säätö ja korjaus on jätettävä aina asiantuntevan huoltoteknikon tehtäväksi.

ADVERSEL: USYNLIG LASERSTRÅLING VED ÅBNING.
UNDGÅ UDSAETTELSE FOR STRÅLING.

VARO! AVATTAESSA OLET ALTTIINA
NÄKYMÄTTÖMÄLLE LASERSÄTEILYLLE.
ÄLÄ KATSO SÄTEESEEN.

VARNING — OSYNLIG LASERSTRÅLNING NÄR
DENNA DEL ÄR ÖPPNAD. BETRAKTA
EJ STRÅLEN.



THIS COMPACT DISC PLAYER IS CLASSIFIED
AS A CLASS 1 LASER PRODUCT.
THE CLASS 1 LASER PRODUCT LABEL IS
LOCATED ON THE REAR EXTERIOR.

1.4. Voltage Selectors

Voltage selector is installed on the Rear Panel of the MB-1s/2s/3s (OTR). The voltage selector can select either 110-127V or 220-240V at customer's disposal.

1.5. Handling the Laser Pickup

In case of repair or replacement of the Laser Pickup, pay attention to the following handling instructions since the laser diode in the Laser Pickup is not resistant to static electricity.

(1) Grounding

When you repair a Laser Pickup, first ground the human body, as well as the measuring instruments and other tools (with particular caution to soldering iron). What's more, your workbench and floor should desirably be grounded using conductive sheet or copper plate. See Fig. 1.1 on next page.

NOTE: Be careful so as not to let your clothes touch the Laser Pickup, as static electricity on the clothes will not be released even if your body is grounded.

(2) Discharge of Electricity

Be sure to discharge electricity from objects brought into contact with the Laser Pickup (i.e., soldering iron, tweezers, probes, volt-ohm-meter probes, etc.) before starting work by contacting them with the body chassis. Besides, never touch the Laser Pickup while power is applied.

(3) Soldering Iron to be Used

The soldering iron for use in repair work should be: (1) a ceramic soldering iron, (2) a soldering iron with its metal part grounded, or (3) a soldering iron whose insulation resistance after five minutes of power application is 10 M-ohm or more at 500 VDC. Soldering should be completed promptly, at a soldering iron temperature of 320° max (39 W). A soldering iron heated above this temperature can break down the laser diode.

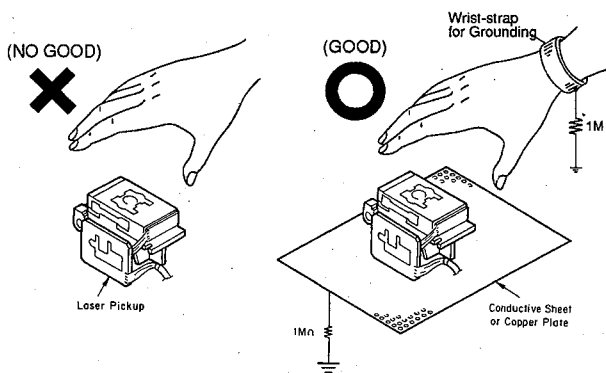

Fig. 1.1 Handling the Laser Pickup

1.6. Sticker Operation Check Function at Power ON

A series of sticker operation can be checked at power ON by grounding the RAM Reset signal line on the Main P.C.B. Ass'y. This function is useful to check whether any CD is left in the sticker before returning the unit to the customer.

- (1) Turn OFF the power.
- (2) Remove the Top Cover Ass'y.
- (3) Short the RAM Reset jumper wires. See Fig. 1.2.
- (4) Turn ON the power and then remove shorting.
- (5) The sticker raises to the uppermost position, and then starts a series of CD unload operation as follows:

Disc No.: 7 → 6 → 5 → 4 → 3 → 2 → 1

- (6) After completion of the sticker operation, the unit returns to standby condition.

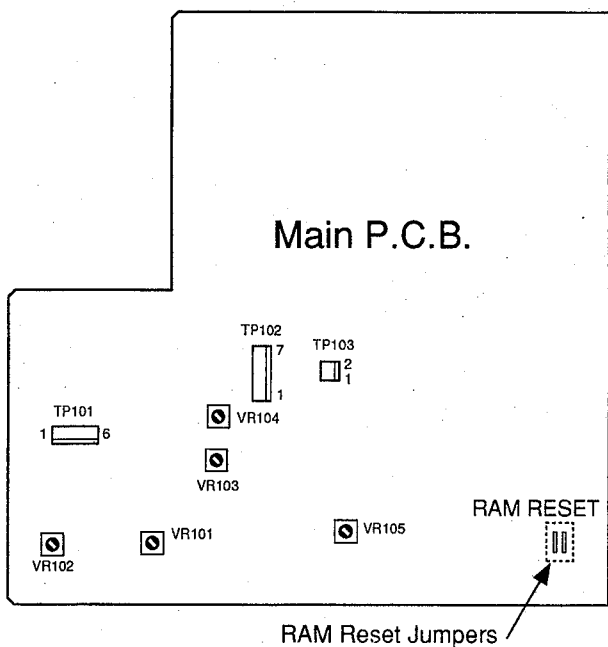

Fig. 1.2 Sticker Operation Check at Power ON

1.7. Package Ass'y and Accessory Ass'y

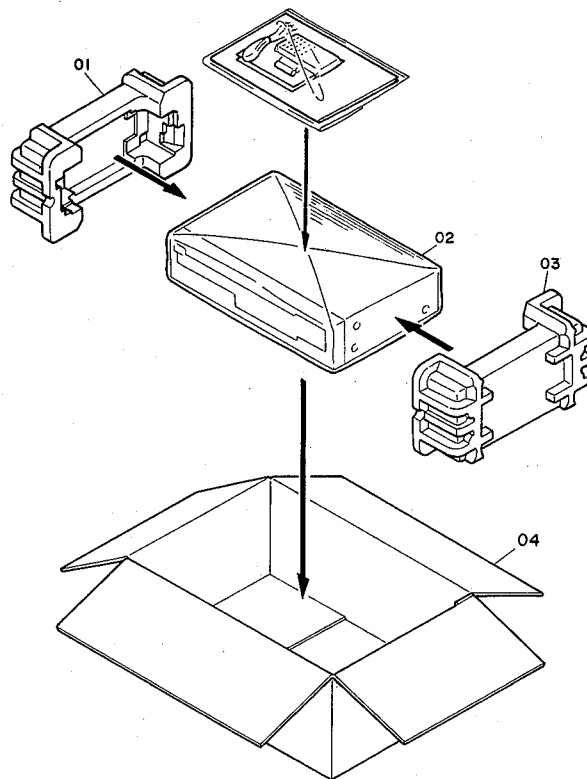

Fig. 1.3

Schematic Ref. No.	Part No.	Description	Q'ty
Package Ass'y			
01	0F04817A	Packing L	1
02	0F04818A	Soft Sheet	1
03	0F04822B	Packing R	1
04	0F04813A	Carton Box [MB-1s]	1
	0F04814A	Carton Box [MB-2s]	1
	0F04815A	Carton Box [MB-3s]	1

Schematic Ref. No.	Part No.	Description	Q'ty
Accessory Ass'y			
DA04777A		Accessory Ass'y [MB-1s, 2s] (USA, CAN)	1
DA04782A		Accessory Ass'y [MB-1s, 2s] (EP)	1
DA04779A		Accessory Ass'y [MB-1s, 2s] (UK)	1
DA04781A		Accessory Ass'y [MB-1s, 2s] (AUS, OTR)	1
DA04780A		Accessory Ass'y [MB-1s, 2s] (JPN)	1
DA04778A		Accessory Ass'y [MB-3s] (USA, CAN)	1
DA04786A		Accessory Ass'y [MB-3s] (EP)	1
DA04783A		Accessory Ass'y [MB-3s] (UK)	1
DA04785A		Accessory Ass'y [MB-3s] (AUS, OTR)	1
DA04784A		Accessory Ass'y [MB-3s] (JPN)	1
DG04773A		Remote Control Unit [MB-1s, 2s]	1
DG04775A		Remote Control Unit [MB-3s]	1
0B90462A		Battery UM4x1	2
0D03092B		Poly Bag	1
0D06142A		W Pin Pin Cord Ass'y [MB-1s, 2s]	1
0D06431A		Pin Plug Cord [MB-3s]	1
0D06503B		Owner's Manual (English)	1
0D06504B		Owner's Manual (French)	1
0D06505B		Owner's Manual (German)	1
0D06506B		Owner's Manual (Japanese)	1

2. REMOVAL PROCEDURES

2.1. Mechanism Ass'y

- (1) Remove the Top Cover.
- (2) Turn ON the power and press the Eject/Load button to eject the Tray Ass'y.
- (3) Remove the Tray Panel Ass'y from the Tray Ass'y upwardly.
- (4) Press the Eject/Load button to load the Tray Ass'y.
- (5) Turn OFF the power and unplug the power cord from the wall outlet.
- (6) To disassemble the Front Panel Ass'y, remove 4 screws at both ends and 4 screws (3 screws for MB-3s) on the bottom.
- (7) Shortcircuit the lands "A" of the Laser Pickup. Refer to Fig. 2.1.

CAUTIONS: 1. Use a soldering iron whose metal part is grounded, or a ceramic soldering iron.

2. Do not forget shortcircuiting the lands "A" as the laser diode in the Laser Pickup will be damaged when the connectors of the Laser Pickup are removed from the Main P.C.B. Ass'y.

- (8) Disconnect 5 connectors of the Mechanism Ass'y.
- (9) Remove screws F01 (3 pcs.) and F02 (2 pcs.), and disassemble F03 (Mechanism Ass'y) and F04 (Mecha Holder).
- (10) Remove 7 screws to remove F04 (Mecha Holder) from F03 (Mechanism Ass'y).

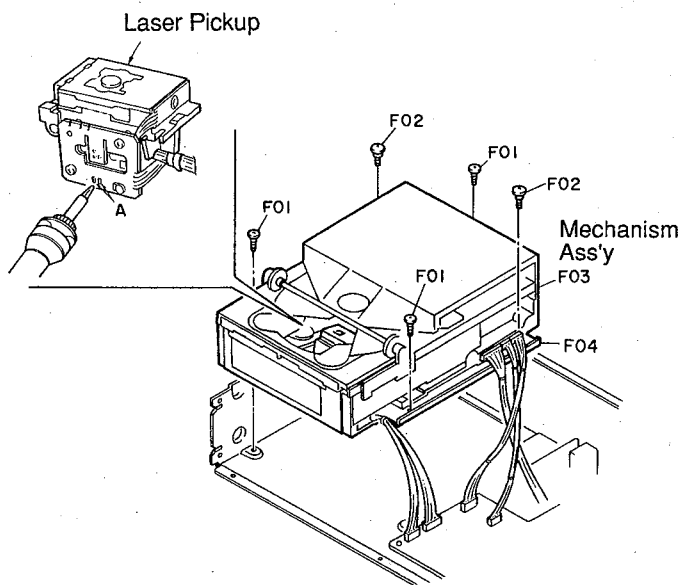

Fig. 2.1

2.2. Mechanism Top Cover

Refer to Figs. 2.2.1 and 2.2.2.

- (1) Remove the Mechanism Ass'y. Refer to item 2.1.
- (2) Remove screws F01 (4 pcs.) and disassemble F02 (Top Cover).
- (3) Remove F03 (Assist Arm).

NOTE: When assembling F03 (Assist Arm), make sure that F03 (Assist Arm) is in place as shown in the figure.

Also, make sure that the lowest carriage is held by the angle "B" of F03 (Assist Arm) as shown in Fig. 2.2.2 so that the carriages are in horizontal position. (Refer to "Leveling the carriages at the left side" in item 2.7.3.)

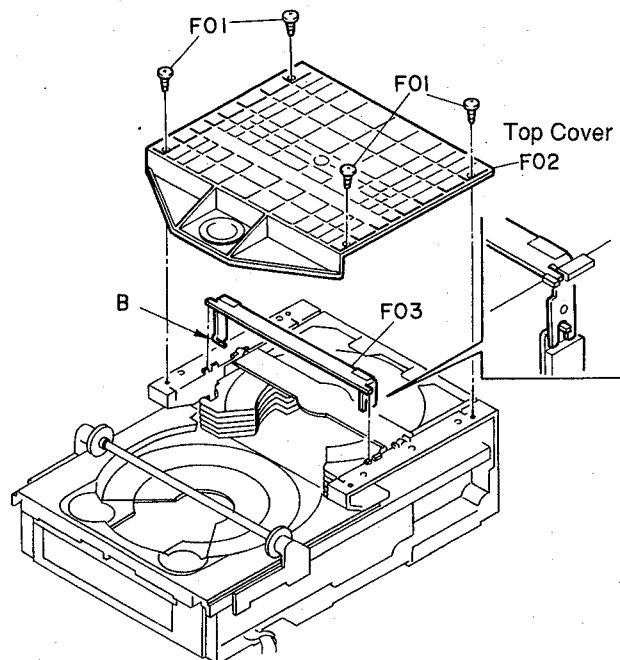

Fig. 2.2.1

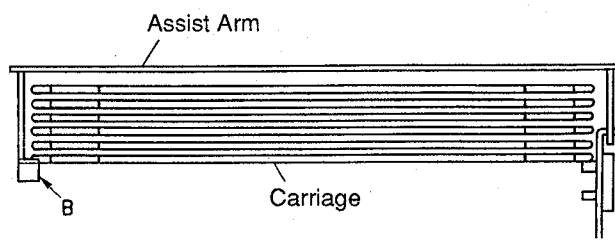

Fig. 2.2.2 Leveling the carriages at the left side

2.3. Drawing the Tray Ass'y

Refer to Fig. 2.3.

- (1) Remove the Mechanism Ass'y. Refer to item 2.1.
- (2) Turn the pulley in the direction of the arrow to draw the Tray Ass'y. (You can only access to the bottom part of the pulley.)
- (3) After drawing the Tray Ass'y about 3cm or so, you can draw the rest of it by hand.

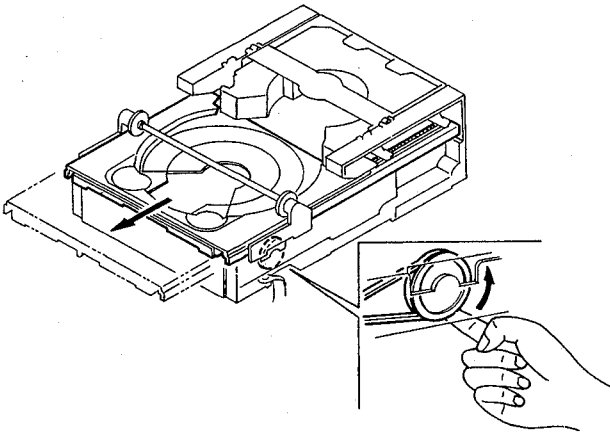

Fig. 2.3

2.4. Laser Pickup

2.4.1. Removing the Laser Pickup

Refer to Fig. 2.4.1.

- (1) Draw the Tray Ass'y. Refer to item 2.3.
- (2) Remove screws F01 (2 pcs.) and disassemble F02 (Plate Rack).
- (3) Remove screws F03 (4 pcs.) and disassemble F04 (Laser Pickup with Guide Bars A and B).
- (4) Pull out the Guide Bars A and B from the Laser Pickup.

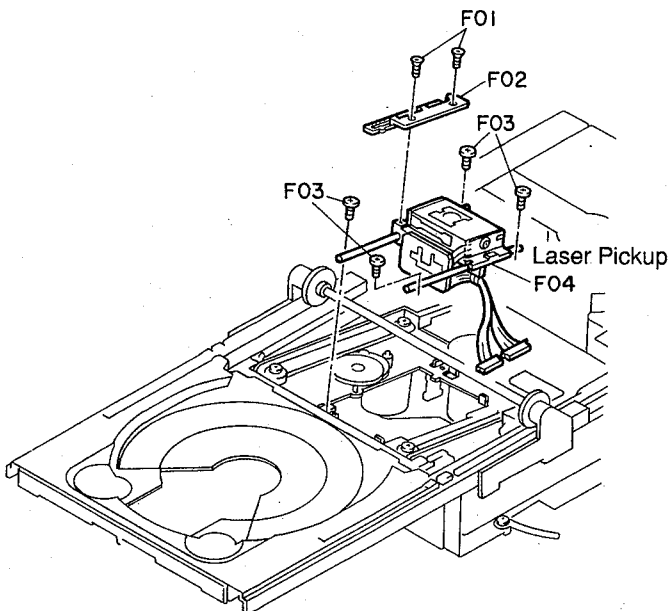

Fig. 2.4.1

2.4.2. Installing a New Laser Pickup

Refer to Fig. 2.4.2.

NOTE: As a Laser Pickup is packed in a conductive pack, do not take it out of the pack until you need it.

- (1) Install the Laser Pickup by reversing the above procedure.
- (2) Before fixing the Mechanism Ass'y with screws F01 and F02, connect the connectors of the Laser Pickup to the Main P.C.B. Ass'y. Then, remove the soldering bridge on the lands "A" shown in the figure with a soldering iron whose metal part is grounded or with a ceramic iron.

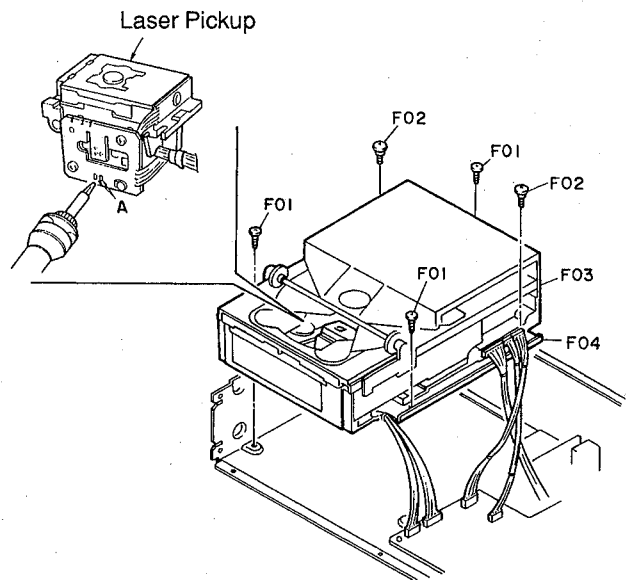

Fig. 2.4.2

2.5. Tray Ass'y

2.5.1. Removing the Tray Ass'y

Refer to Fig. 2.5.1.

- (1) Draw the Tray Ass'y. Refer to item 2.3.
- (2) Remove screws F01 (4 pcs.) and disassemble F02 (Tray Holder L) and F03 (Tray Holder R).
- (3) Remove F04 (Timing Ass'y).
- (4) Remove F05 (Tray Ass'y).

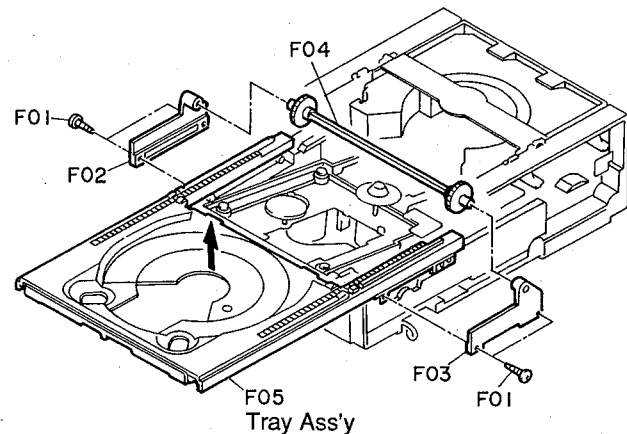

Fig. 2.5.1

2.5.2. Installing the Tray Ass'y

When installing the Tray Ass'y, perform positioning as follows:

- (1) Turn the pulley in the direction of the arrow until it stops. Refer to Fig. 2.5.2.
- (2) Turn the pulley in the opposite direction a little so that the center of two marks (holes) "C" on the S-F-Gear is in the vertical position. Refer to Fig. 2.5.2.
- (3) Place the Tray Ass'y so that the protrusion "D" of the Tray Ass'y is positioned between the marks (holes) "C" on the S-F-Gear. Refer to Fig. 2.5.3.
- (4) Reverse the removal procedure in item 2.5.1.

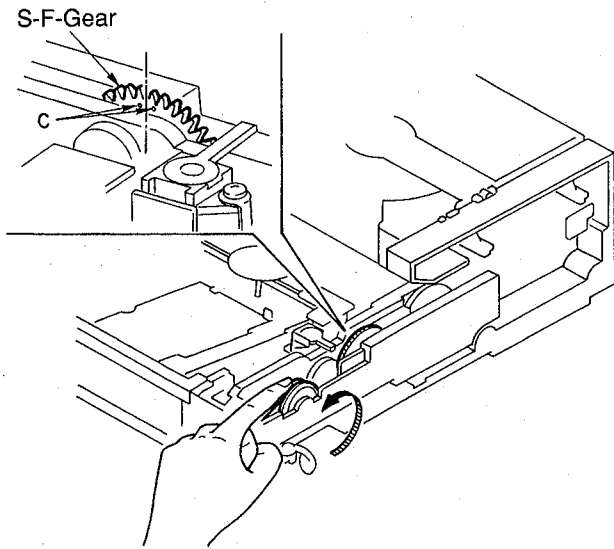

Fig. 2.5.2

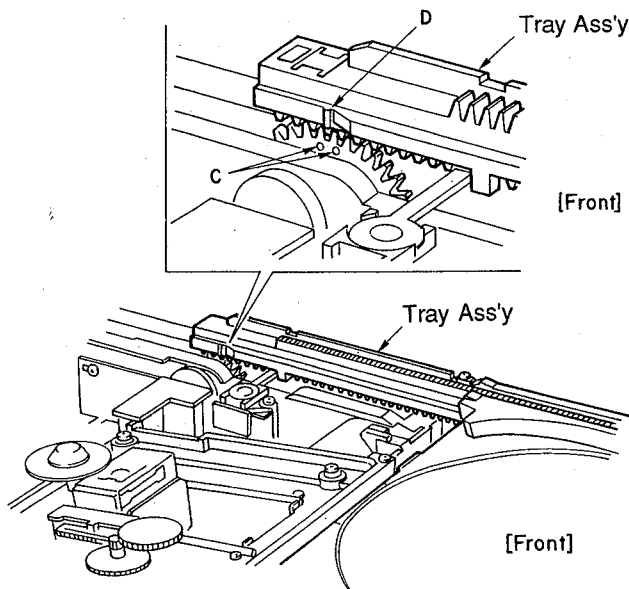

Fig. 2.5.3

2.6. Drive Unit Section

Refer to Fig. 2.6.

- (1) Remove the Laser Pickup. Refer to item 2.4.
- (2) Remove the Tray Ass'y. Refer to item 2.5.
- (3) Remove screws F01 (2 pcs.) and disassemble F02 (Disc Det. P.C.B.).
- (4) Remove screws F03 (2 pcs.) and disassemble F04 (Mecha B Stopper).
- (5) Disconnect a connector and remove F05 (Drive Unit Section).

NOTE: When installing F05 (Drive Unit Section), insert the pin "E" of the Drive Unit Section into the groove of the Mecha UD Cam as shown in the figure.

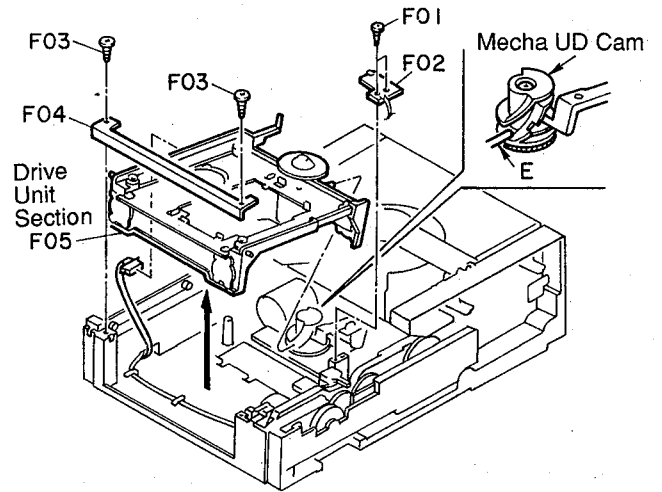

Fig. 2.6

2.7. Side Chassis R Section

2.7.1. Removing the Side Chassis R Section

Refer to Fig. 2.7.1.

- (1) Remove the Drive Unit Section. Refer to item 2.6.
- (2) Remove a screw F01 and F02 (Wire Clamper), and disassemble F03 (Eject/Close P.C.B.).
- (3) Remove a screw F04 and disassemble F05 (Store P.C.B.).
- (4) Disconnect 2P connector of the Loading Motor from the Connector P.C.B. at the back of the Mechanism Unit.
- (5) Remove screws F06 (2 pcs.) and F07 (3 pcs.), and disassemble F08 (Side Chassis R Section) in the direction of the arrow.

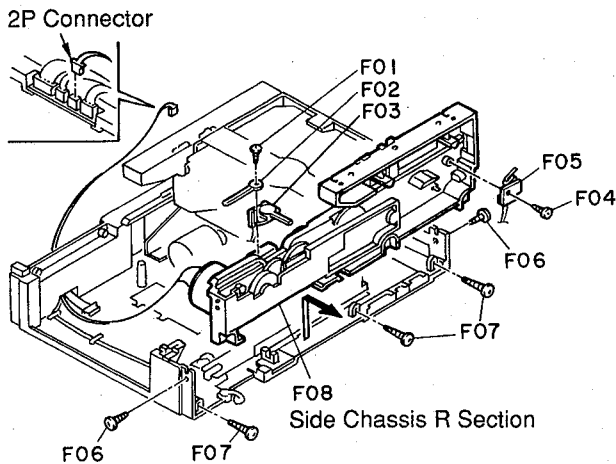

Fig. 2.7.1

2.7.2. Accessing to the Gears and Loading Motor Belt

Refer to Fig. 2.7.2.

- (1) Remove screws F09 (3 pcs.), F10 (1 pce.) and F11 (2 pcs.), and disassemble F12 (Gear Holder). Then, you can access to the gears (S-F-Gear, S-I-Gear and S-M-Gear) and Loading Motor Belt F13 (Belt-C-S).

NOTE: When you replace one of gears, perform gear positioning according to 3.1 "Gear Positioning".

- (2) Remove screws F14 (3 pcs.) and disassemble F15 (Change Plate Ass'y) and F16 (Carriage Opener). Then, you can access to the Change Gear.

NOTE: When you replace the Change Gear, perform gear positioning according to 3.1 "Gear Positioning".

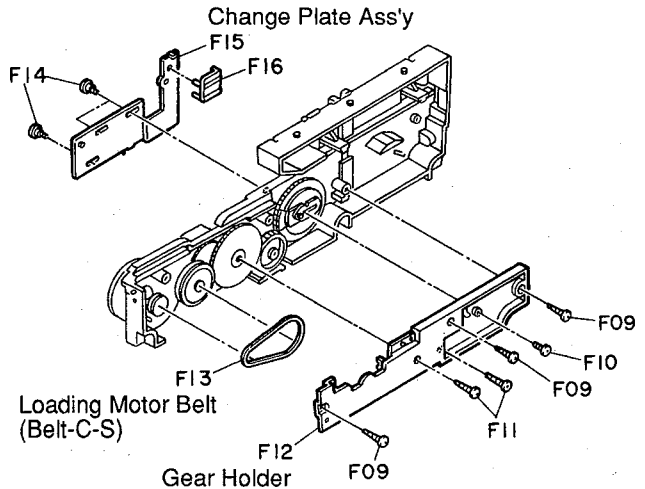

Fig. 2.7.2

2.7.3. Installing the Side Chassis R Section

NOTE: When you replace one of gears in the Side Chassis R Section, perform 3.1 "Gear Positioning" before installing the Side Chassis R Section.

- (1) Push the Change Arm against the D6-ST-Gear so that they are engaged each other. Refer to Fig. 2.7.3.
- (2) Place the Side Chassis R Section so that the pin "F" of the Side Chassis R Section is inserted into the hole in the Change Arm, as shown in Fig. 2.7.3.

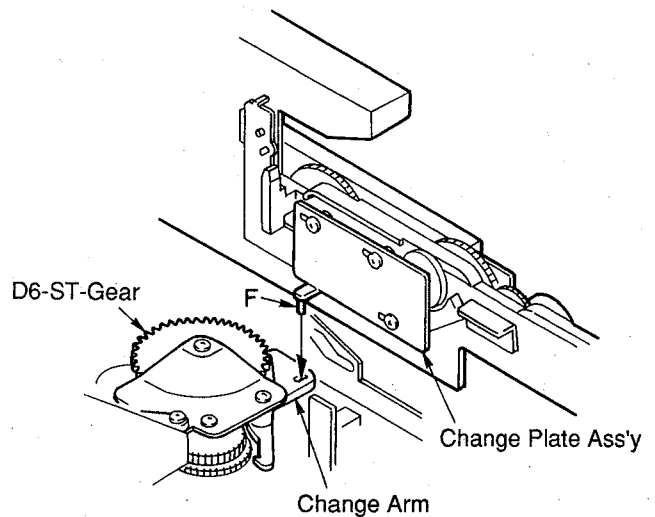

Fig. 2.7.3

- (3) Leveling the carriages:
The carriages must be set in correct position where they are in horizontal position.

• **Leveling carriages at the right side**

Lift the right end of the carriages (6 pcs.) with your finger tip as shown in Fig. 2.7.4, and place the lowest carriage onto the pin "G" (white one).

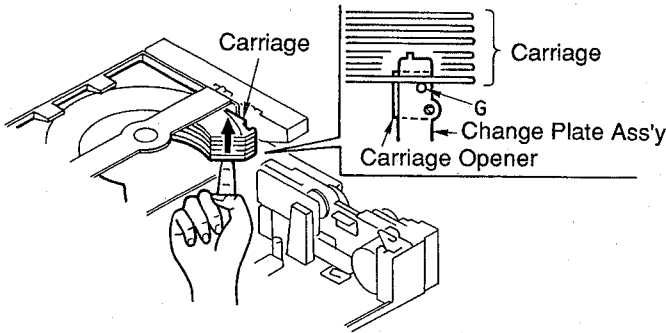

Fig. 2.7.4 Leveling the carriages at the right side

• **Leveling the carriages at the left side**

Lift the left end of the carriages (6 pcs.) with your finger tip and place the lowest carriage onto the angle "B" of the Assist Arm. Refer to Fig. 2.7.5.

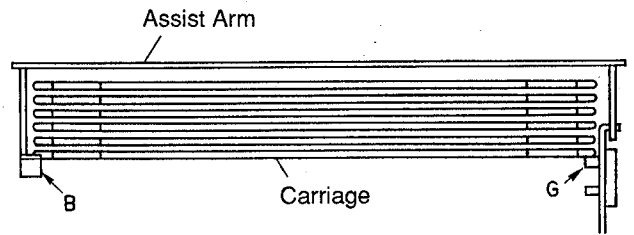

Fig. 2.7.5 Leveling the carriages

2.8. Side Chassis L

Refer to Fig. 2.8.

- (1) Remove the Drive Unit Section. Refer to item 2.6.
- (2) Remove screws F01 (3 pcs.) and F02 (2 pcs.), and disassemble F03 (Side Chassis L).

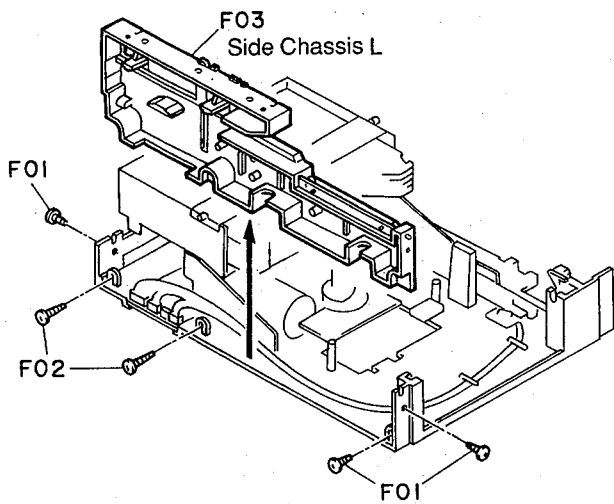

Fig. 2.8

2.9. Stoker Ass'y and Main Chassis Section

Refer to Fig. 2.9.

- (1) Remove the Side Chassis R Section and Side Chassis L. Refer to items 2.7 and 2.8.
- (2) Remove F01 (Stoker Ass'y including the carriages) from F02 (Main Chassis Section) as shown in the figure.

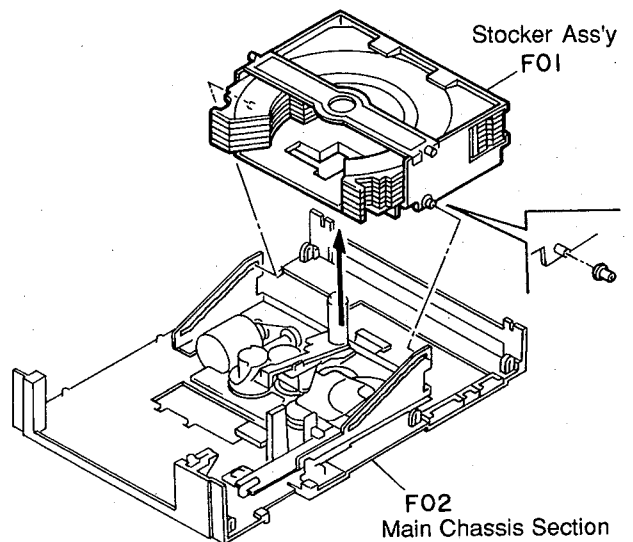

Fig. 2.9

3. MECHANICAL ADJUSTMENTS

3.1. Gear Positioning in the Side Chassis R Section

When one of the gears in the Side Chassis R section is replaced, perform the following gear positioning. (To access to the gears, refer to 2.7 "Side Chassis R Section".)

3.1.1. Positioning Three Gears

Refer to Fig. 3.1.1.

- (1) Align the marks (holes) of the S-I-Gear with the mark (hole) of the S-F-Gear and S-M-Gear as shown in the figure.

NOTE: The S-F-Gear and S-M-Gear have another mark (hole). Pay attention so as not to align with the wrong hole.

- (2) Insert the pin of the Tray Arm Ass'y into the groove of the S-M-Gear as shown in the figure.

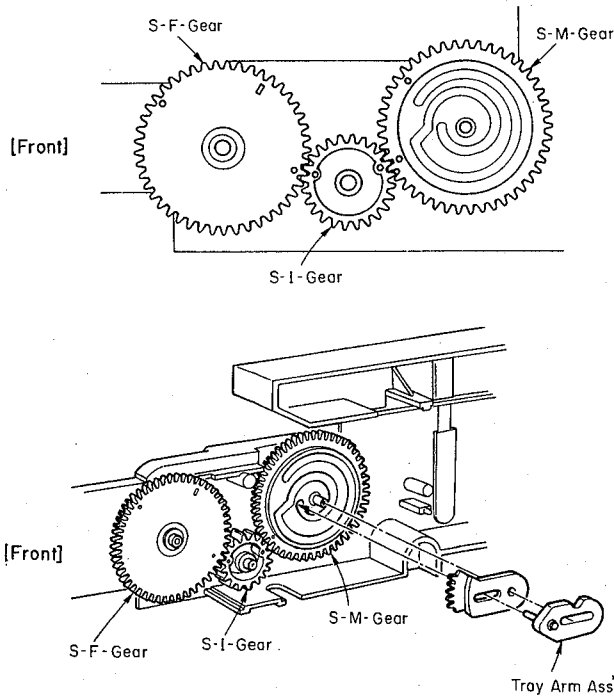

Fig. 3.1.1 Positioning of Three Gears

3.1.2. Positioning the Change Gear

Refer to Fig. 3.1.2.

- (1) Position the Change Gear so that the notch of the Change Gear meets the mark "A" of the S-F-Gear.
- (2) Insert the pin of the Change Plate Ass'y into the groove of the Change Gear, and mount the Change Plate Ass'y with three screws.

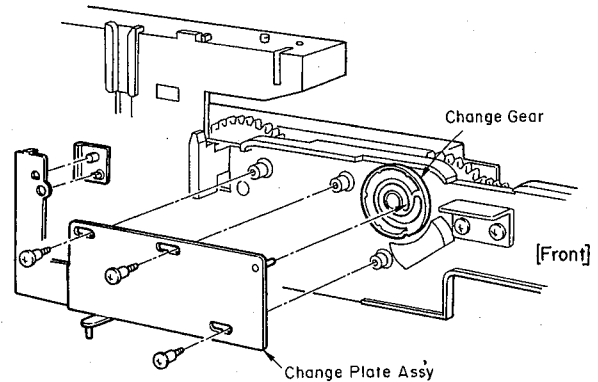
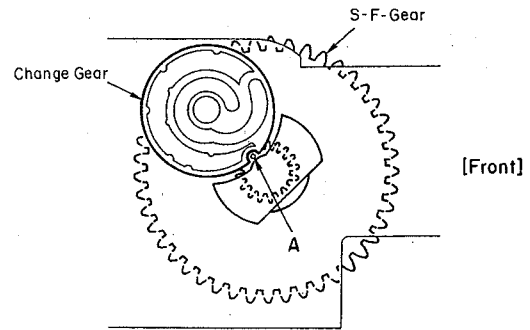

Fig. 3.1.2 Positioning of the Change Gear

3.2. Positioning the Tray Ass'y

When installing the Tray Ass'y on the mechanism unit, perform the following positioning. (Refer to 2.5.2 "Installing the Tray Ass'y".)

- (1) Install the Tray Ass'y so that the protrusion "B" of the Tray Ass'y is positioned between two marks (holes) "C" of the S-F-Gear. Refer to Fig. 3.2.

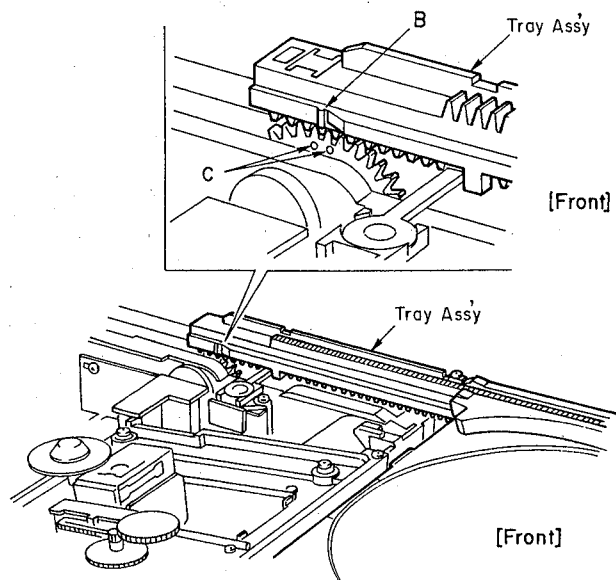

Fig. 3.2 Positioning of the Tray Ass'y

3.3. Lubrication

Apply the specified lubricant (grease) to the following places when parts are replaced. (Refer to Figs. 7.3 to 7.5.)

<u>Fig.</u>	<u>Ref. No.</u>	<u>Location</u>	<u>Lubricant</u>
(Mechanism Ass'y)			
7.3	07	Stocker Ass'y	
		• Carriage contacting surface (both sides)	FLOIL FL777
		• Boss (both sides)	FLOIL G425
	09	Side Chassis L	FLOIL G425, FL777
	10	Side Chassis Section	FLOIL G425, FL777
	13	Tray Ass'y	
		• Carriage contacting surface (Upper/Lower, both sides)	FLOIL FL777
		• Carriage Shaft R	FLOIL G425
		• Carriage Shaft L	FLOIL FL777
(Side Chassis R Section)			
7.4	01	Change Plate Ass'y (3 places)	FLOIL G425
	03	Change Gear (Groove)	FLOIL G425
	06	Side Chassis R Sub Ass'y (5 places)	FLOIL G425
	09	Side Idler	FLOIL G425
	12	S-M-Gear (Groove)	FLOIL G425
	13	Tray Stopper	FLOIL G425
	14	Tray Arm Ass'y	FLOIL G425
	15	Gear Holder (Groove)	FLOIL G425
(Main Chassis Section)			
7.5	04	Mecha UD Cam	FLOIL G425
	11	D5-ST-Gear	FLOIL G425
	12	Lock Idler	FLOIL G425
	13	D7-ST-Gear	FLOIL G425
	14	D6-ST-Gear	FLOIL G425
	16	Stocker Cam (5 places)	FLOIL G425
	18	ST-Worm-Gear	FLOIL FL777
	20	Worm Shaft (Shaft head and shaft end)	FLOIL G425
	24	Main Chassis Ass'y (7 places)	FLOIL G425

NOTE: We suggest that you use the above specified lubricant or equivalent type.

The company dealing in the above lubricant is as follows:

Kanto Chemicals CO., Ltd., 2-7 Kanda Sakuma-cho, Chiyoda-Ku, Tokyo, Japan

• Name of Lubricant: FLOIL G425/FLOIL FL777

4. MEASUREMENT INSTRUMENTS AND JIGS

- (1) Oscilloscope (15 MHz or more)
- (2) DC Voltmeter
- (3) Oscillator
- (4) Frequency Counter
- (5) Distortion Meter (MB-1s only)
- (6) Philips Test Disc 5/5A or 444/444A
- (7) SONY Test Disc YEDS-7 (Type 3)
- (8) CD Player Test Unit Set (DA09157A)

Consisting of the following items:

- CD Player Test Unit 1 pce.
- Test Unit Cable for MB-1s/2s/3s/4s, 1000Mb, CD Player 1/2/3, Sound Space 7 (DA09158A) 1 pce.
- CD Player 4 Test Unit Cable (DA09156A) 1 pce.
- CD Cassette Player 1 Test Unit Cable (DA09162A) 1 pce.

NOTE: If you already have the CD Player Test Unit for the following Models, you can use it for MB-1s/2s/3s.

- MB-4s
- Sound Space 7
- 1000Mb/i, 1000Mb
- CD Player 1/2/3
- CD Cassette Player 1
- CD Player 4 (The test unit cable is not compatible with that for MB-1s/2s/3s.)

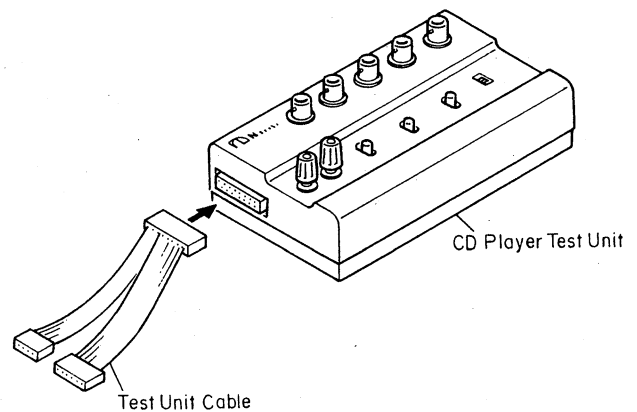

Fig. 4.1 Test Unit

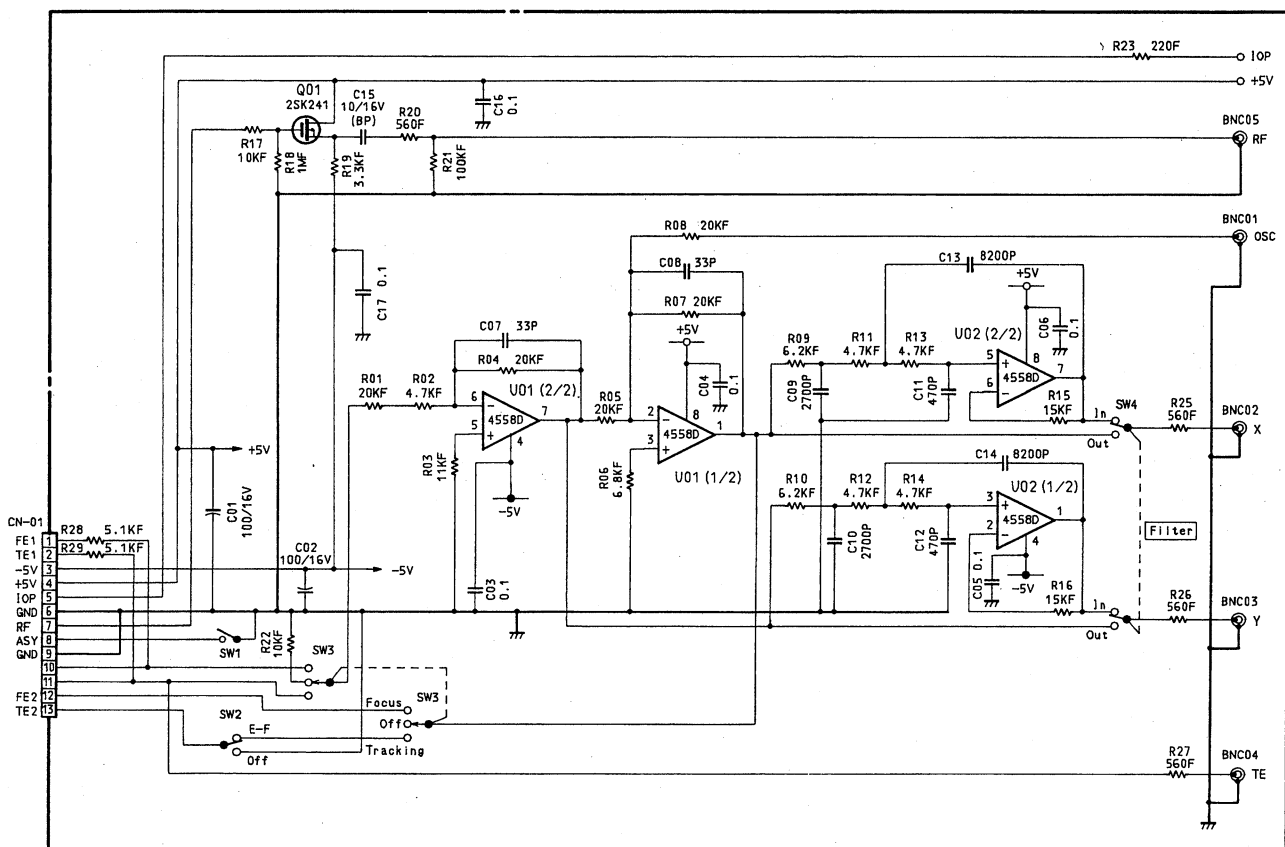

Fig. 4.2 Circuit of the Test Unit

5. PARTS LOCATION FOR ELECTRICAL ADJUSTMENT

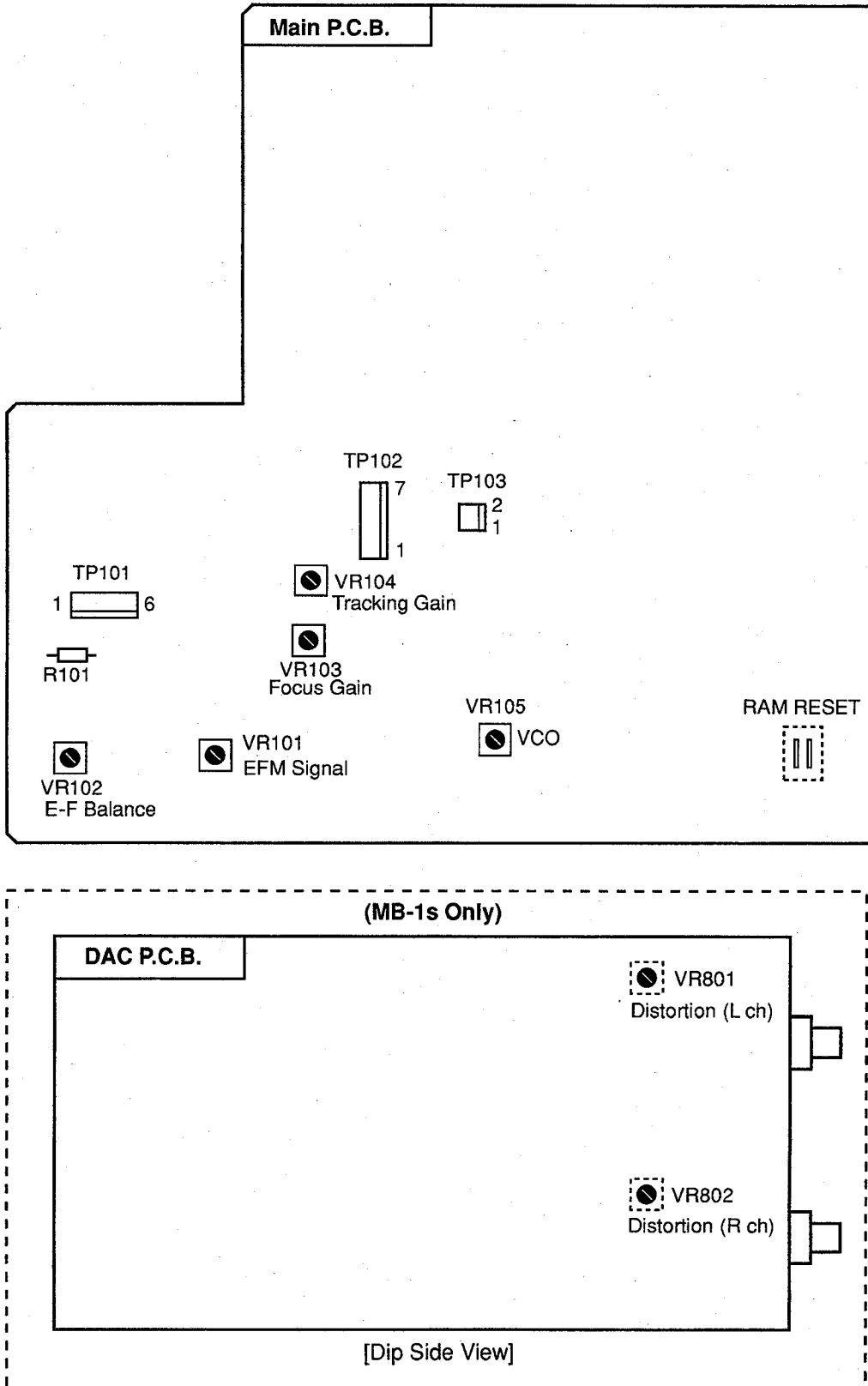

Fig. 5

6. ELECTRICAL ADJUSTMENTS

NOTES:

1. Preset position of the semi-fixed volumes:

When the Main P.C.B. Ass'y or semi-fixed volume VR101, VR102, VR103, or VR104 is replaced with new one, preset the following semi-fixed volumes to their mechanical center positions before starting adjustment.
VR101, VR102, VR103 and VR104

2. Connecting the Test Unit:

For adjusting the steps 4 through 6, the Test Unit is required. In steps 4 through 6 **ONLY**, connect the 7P cable of the Test Unit to the test connector TP102 on the Main P.C.B. Ass'y.

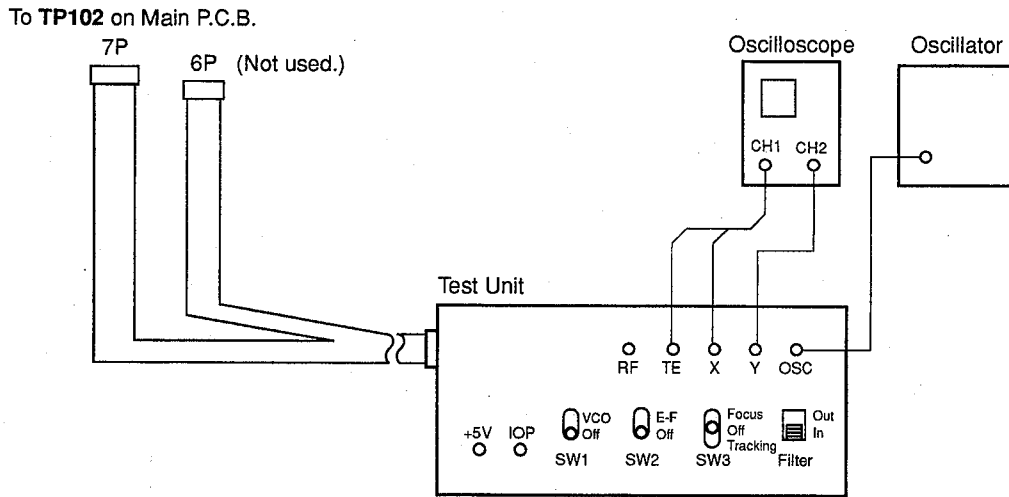
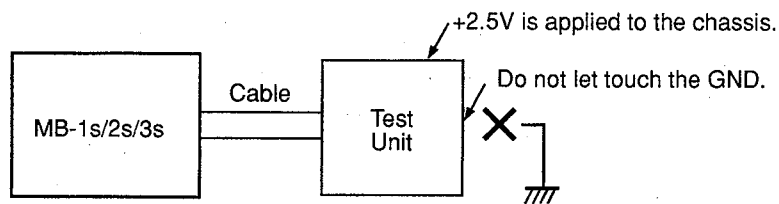
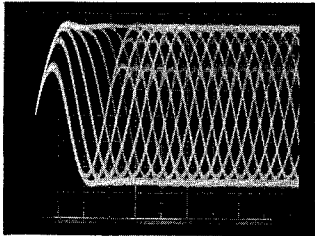
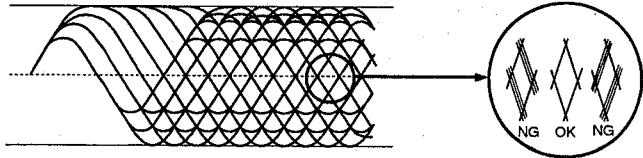

Fig. 6 Test Unit Connecting Diagram

CAUTION:

DO NOT let touch the chassis of the Test Unit to the measurement instrument as well as the MB-1s/2s/3s since +2.5V is applied to the chassis of the Test Unit when the test unit cable is connected to the MB-1s/2s/3s.

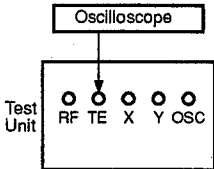
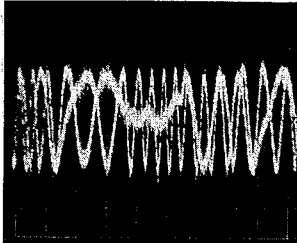
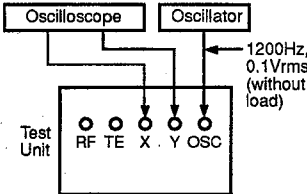
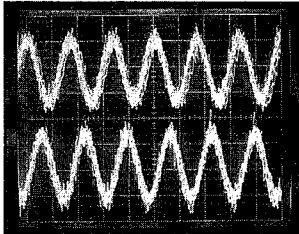
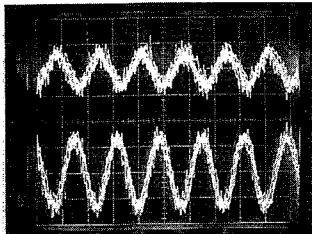

STEP	ITEM	SIGNAL SOURCE	OUTPUT CONNECTION	ADJUSTMENT	REMARKS
1	Laser Current Check	Philips Test Sample 5 or 444	DC Voltmeter between pins 1 (IOP) and 3 (+5V) of TP101 on Main P.C.B. DC Voltmeter Common: Pin 3 (+5V)		<ol style="list-style-type: none"> Turn the power ON and load the test disc. Play back the test disc and calculate the current flowing into R101 on the Main P.C.B. Ass'y from the following formula. $I = \frac{\text{Voltmeter Value}}{R101 (10 \text{ Ohms})} = \text{oo.o mA}$ Check that the calculated current is in a range of 50 to 60 mA. <p>Note: If the current doubles, pickup will be defective.</p>
2	VCO Frequency Adjustment	None	Frequency Counter (10/1 probe) between pins 2 (PLCK) and 1 (GND) of TP-103 on Main P.C.B.	Main P.C.B. VR105	<ol style="list-style-type: none"> Set the shorting pin between pins 5 (GND) and 6 (ASY) of TP101 on Main P.C.B. Adjust VR105 to obtain 4.322 ± 0.005 MHz on the frequency counter. Remove the shorting pin.
3	EFM Signal Adjustment	Philips Test Sample 5 or 444	Oscilloscope between pins 2 (RF) and 4 (VR) of TP101 on Main P.C.B. Oscilloscope Common: Pin 4 (VR)	Main P.C.B. VR101	<ol style="list-style-type: none"> Play back the first track of the test disc. Adjust VR101 until waveform amplitude becomes maximum and the waveform becomes clear (not thick) as shown below: <div style="text-align: center;">  </div> <p>Oscilloscope Setting: AC Mode, 0.2 V/div, 0.5 μs/div</p>
					
4	E-F Balance Adjustment (Supplementary Beam Balance Adjustment)	Philips Test Sample 5 or 444	Oscilloscope to TE Connector of Test Unit	Main P.C.B. VR102	<ol style="list-style-type: none"> Connect the 7P cable of the Test Unit to TP102 on the Main P.C.B. Ass'y. Play back the first track of the test disc. Set SW2 of the Test Unit to E-F position. Adjust VR102 so that the center level of the waveform is within the range of $0 \text{ V} \pm 0.1 \text{ V DC}$ as shown below: <p>(To be continued.)</p>

STEP	ITEM	SIGNAL SOURCE	OUTPUT CONNECTION	ADJUSTMENT	REMARKS
	SW1: OFF SW2: E-F	SW3: OFF Filter: OUT	 <p>Connecting Diagram</p>		 <p>--- Center Level</p> <p>Oscilloscope Setting: DC Mode, 1 V/div, 1 ms/div</p> <ol style="list-style-type: none"> Set SW2 to OFF position. Remove the 7P cable from TP102.
5	Tracking Gain Adjustment	Philips Test Sample 5 or 444	Oscillator to OSC Connector of Test Unit Oscilloscope to Test Unit <ul style="list-style-type: none"> • CH1 to X • CH2 to Y 	Main P.C.B. VR104	<ol style="list-style-type: none"> Connect the 7P cable of the Test Unit to TP102 on the Main P.C.B. Ass'y. Set the output of oscillator to 1200 Hz, 0.1 Vrms without connecting it to the Test Unit. Note the position of the output control of the oscillator. Connect the oscillator output to OSC connector of the Test Unit and set its output to 0 V. Set the Filter switch of the Test Unit to IN position. Play back the first track of the test disc. Set the output control of the oscillator to the position noted in 3. Set SW3 of the Test Unit to TRACKING position. Adjust VR104 so that the amplitude of both waveforms on the oscilloscope are equal. (a=b) Set SW3 to OFF position. Remove the 7P cable from TP102. <p>SW1: OFF SW3: TRACKING SW2: OFF Filter: IN</p>  <p>Connecting Diagram</p> <div style="display: flex; justify-content: space-around;"> <div data-bbox="715 1447 887 1469"> <p>Good waveforms</p>  <p>CH1</p> <p>CH2</p> <p>a = b</p> </div> <div data-bbox="1134 1447 1286 1469"> <p>NG waveforms</p>  </div> </div> <p>Oscilloscope Setting: CH1, CH2: 0.2 V/div, DC Mode Time: 0.5 ms/div Mode: Auto, ALT Trigger: CH1</p>

STEP	ITEM	SIGNAL SOURCE	OUTPUT CONNECTION	ADJUSTMENT	REMARKS
6	Focus Gain Adjustment	Philips Test Sample 5 or 444	Oscillator to OSC connector of Test Unit Oscilloscope to Test Unit • CH1 to X • CH2 to Y	Main P.C.B. VR103	<ol style="list-style-type: none"> 1. Connect the 7P cable of the Test Unit to TP102 on the Main P.C.B. Ass'y. 2. Set the output of oscillator to 1000 Hz, 0.1 Vrms without connecting it to the Test Unit. 3. Note the position of the output control of the oscillator. 4. Connect the oscillator output to OSC connector of the Test Unit and set its output to 0 V. 5. Set the Filter switch of the Test Unit to IN position. 6. Play back the first track of the test disc. 7. Set the output control of the oscillator to the position noted in 3. 8. Set SW3 of the Test Unit to FOCUS position. 9. Adjust VR103 so that the amplitude of both waveforms on the oscilloscope are equal. (a=b) 10. Set SW3 to OFF position. 11. Set the Filter switch to OUT position. 12. Remove the 7P cable from TP102. 13. After adjustment, perform "EFM Signal Adjustment" in Step 3.
<p>SW1: OFF SW3: FOCUS SW2: OFF Filter: IN</p> <p>Connecting Diagram</p> <div style="display: flex; justify-content: space-around;"> <div style="text-align: center;"> <p>Good waveforms</p> <p>CH1</p> <p>CH2</p> <p>a = b</p> </div> <div style="text-align: center;"> <p>NG waveforms</p> </div> </div> <p>Oscilloscope Setting: CH1, CH2: 0.2 V/div, DC Mode Time: 0.5 ms/div Mode: Auto, ALT Trigger: CH1</p>					
7	Distortion Adjustment (MB-1s only)	Sony YEDS-7 (Type 3)	Distortion Meter to Output Jacks	DAC P.C.B. VR801 (L) VR802 (R)	<ol style="list-style-type: none"> 1. Play back the first program (1 kHz, 0 dB) of the test disc. 2. Adjust VR801 (L ch) and VR802 (R ch) to obtain minimum distortion.
8	Operation Check	Philips Test Sample 5A or 444A			<p>Play back the following test programs on the test disc (Philips Test Sample 5A or 444A) and make sure that there is no noise and track-jumping.</p> <ul style="list-style-type: none"> • Interruption 500 μm: 6th program • Black Dot 800 μm: 17th program • Simulated fingerprint: 19th program

7. MECHANISM ASS'Y AND PARTS LIST

7.1. Synthesis

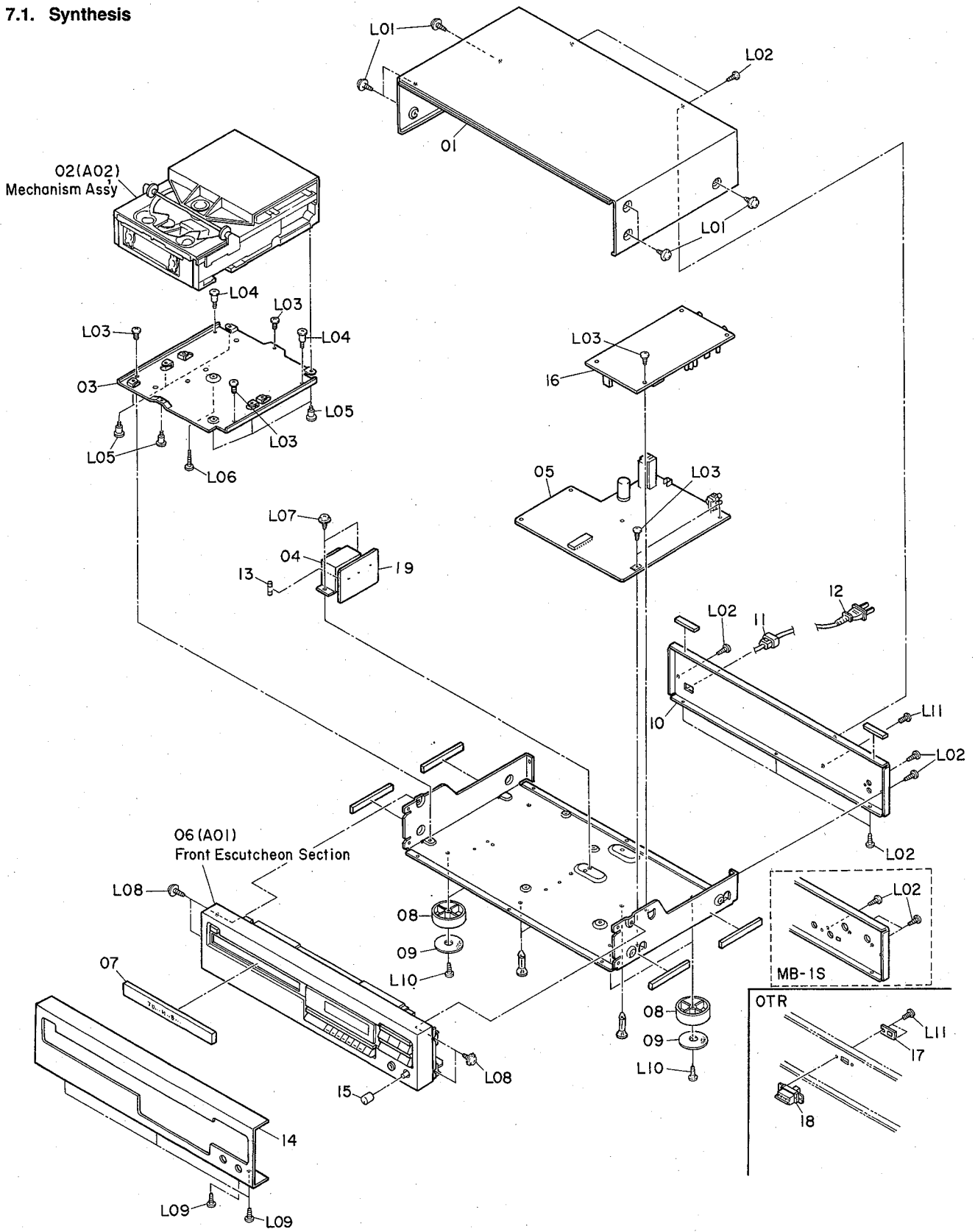

Fig. 7.1

7.1. Synthesis

Schematic Ref. No.	Part No.	Description	Q'ty
		Synthesis	
01	0H06737A	Top Cover	1
02	CG09210A	Mechanism Ass'y	1
03	0J07235D	Mecha Holder	1
04	0B50249A	Power Transformer 120V [MB-1s] (USA, CAN)	1
	0B50252A	Power Transformer 230V [MB-1s] (EP, UK, AUS)	1
	0B50253A	Power Transformer 115/230V [MB-1s] (OTR)	1
	0B50251A	Power Transformer 100V [MB-1s] (JPN)	1
	0B50250A	Power Transformer 120V [MB-2s, 3s, 4s] (USA, CAN)	1
	0B50255A	Power Transformer 230V [MB-2s, 3s, 4s] (EP, UK, AUS)	1
	0B50256A	Power Transformer 115/230V [MB-2s, 3s, 4s] (OTR)	1
	0B50254A	Power Transformer 100V [MB-2s, 3s, 4s] (JPN)	1
05	BA09068A	Main P.C.B. Ass'y [MB-1s]	1
	BA09076A	Main P.C.B. Ass'y [MB-2s]	1
	BA09078A	Main P.C.B. Ass'y [MB-3s]	1
06	—	Front Escutcheon Section	1
07	HA06848A	Tray Panel Ass'y [MB-1s, 2s]	1
	HA06849A	Tray Panel Ass'y [MB-3s]	1
08	0J07247B	Leg	4
09	0J07283A	Leg Cushion	4
10	0H06729A	Rear Panel [MB-1s] (Except OTR)	1
	0H06730A	Rear Panel [MB-1s] (OTR)	1
	0H06731A	Rear Panel [MB-2s] (Except OTR)	1
	0H06732A	Rear Panel [MB-2s] (OTR)	1
	0H06733A	Rear Panel [MB-3s] (Except OTR)	1
	0H06734A	Rear Panel [MB-3s] (OTR)	1
11	0B90280A	Cord Bushing	1
12	0B90205A	Power Cord (USA, CAN)	1
	0B08093U	Power Cord (EP)	1
	0B08348A	Power Cord (UK)	1
	0B05241A	Power Cord (AUS)	1
	0B80336A	Power Cord KP-235 (OTR, JPN)	1
13	0B90376A	Fuse 2A/125V (GGS2) (USA, CAN, OTR, JPN) [F401]	1
	0B90382A	Fuse T1.25A/250V (EP, UK, AUS) [F401]	1
14	0H06714A	Front Panel [MB-1s]	1
	0H06715A	Front Panel [MB-2s]	1
	0H06716A	Front Panel [MB-3s]	1
15	0H06725A	VR Knob [MB-1s, 2s]	1
16	BA09074A	DAC P.C.B. Ass'y [MB-1s] (Except EP)	1
	BA09188A	DAC P.C.B. Ass'y [MB-1s] (EP)	1
17	0H06746A	V. Lock Plate-C (OTR)	1
18	0B07092U	Voltage Selector (OTR)	1
19	—	Transformer P.C.B. Ass'y	1
L01	0E03592A	BT4x6 + Binding Washer-Faced (Black Chromate)	
L02	0E00921A	BT3x8 + Binding (Black Chromate)	
L03	0E00800A	ST3x6 + Binding	
L04	0E03803A	BT3x7 + Binding	
L05	0E03805A	PT3x9.5 + Binding	
L06	0E03806A	PT3x12 + Binding	
L07	0E03664A	ST4x8 + Tapping	
L08	0E03634A	BT3x6 + Binding Washer-Faced	
L09	0E03366A	BT3x8 + Binding Projected (Black Chromate)	
L10	0E03217A	BT4x8 + Binding (Black Chromate)	
L11	0E00985A	M3x6 + Binding	

7.2. Front Escutcheon Section (A01)

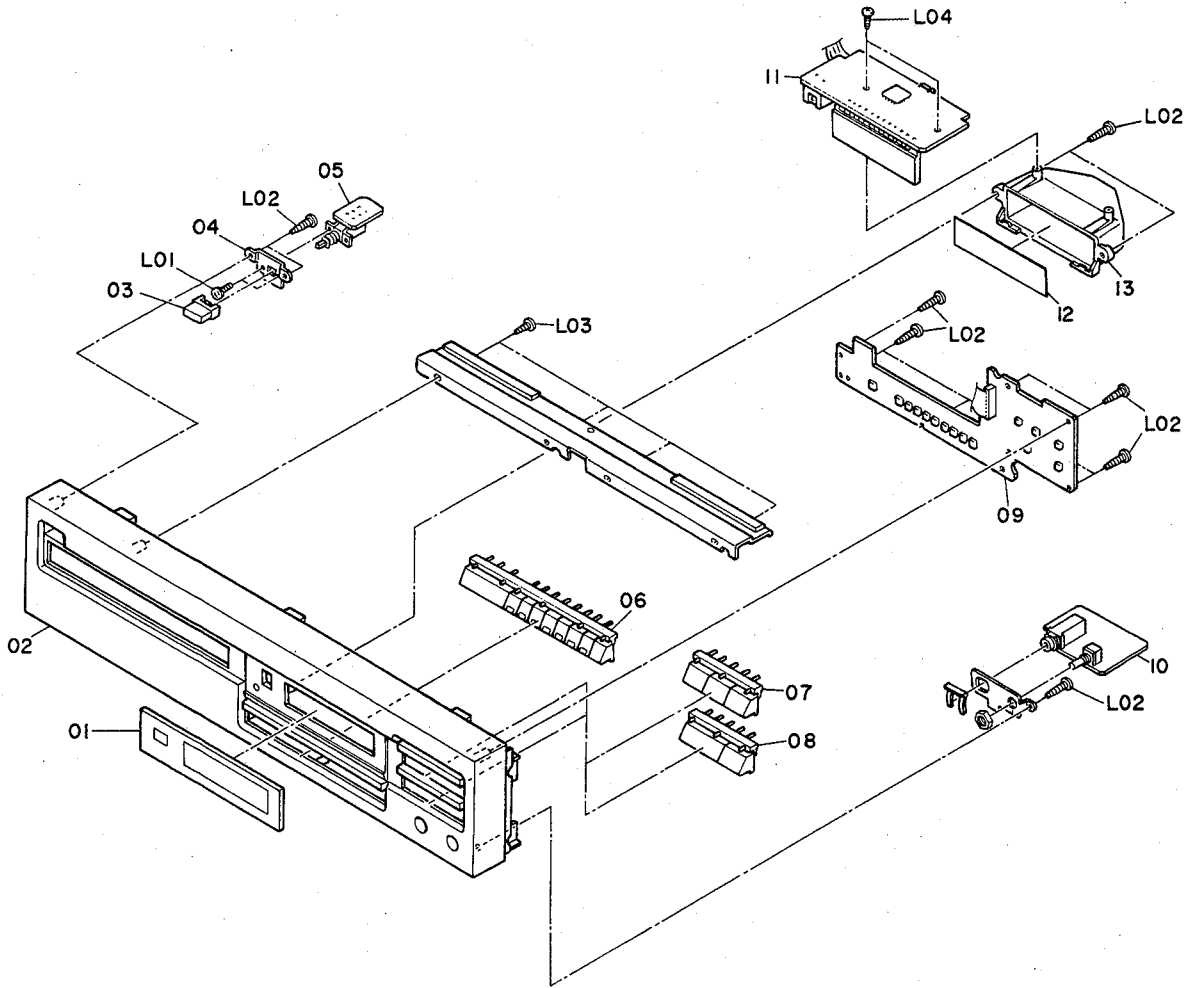

Fig. 7.2

7.2. Front Escutcheon Section

Schematic Ref. No.	Part No.	Description	Q'ty
A01	—	Front Escutcheon Section	1
01	0H06722B	Window	1
02	0H06717B	Front Escutcheon [MB-1s, 2s]	1
	0H06742A	Front Escutcheon [MB-3s]	1
03	0H06724A	Power Knob	1
04	0J07245B	Power Switch Holder	1
05	BA09071A	Power Switch P.C.B. Ass'y	1
06	0H06719A	Control Knob 9	1
07	0H06720A	Control Knob 3	1
08	0H06721A	Control Knob 2	1
09	BA09070A	Key P.C.B. Ass'y	1
10	BA09072A	Headphone P.C.B. Ass'y [MB-1s]	1
	BA09084A	Headphone P.C.B. Ass'y [MB-2s]	1
11	BA09069A	Display P.C.B. Ass'y	1
12	0J07241A	LCD Sheet	1
13	0J07239A	LCD Holder	1
L01	0E00696A	M2x5 + Pan	
L02	0E03769A	PT2.6x8 + Binding	
L03	0E03813A	PT2.6x6 + Binding	
L04	0E03638A	PT2x6 + Binding	

7.3. Mechanism Ass'y (A02)

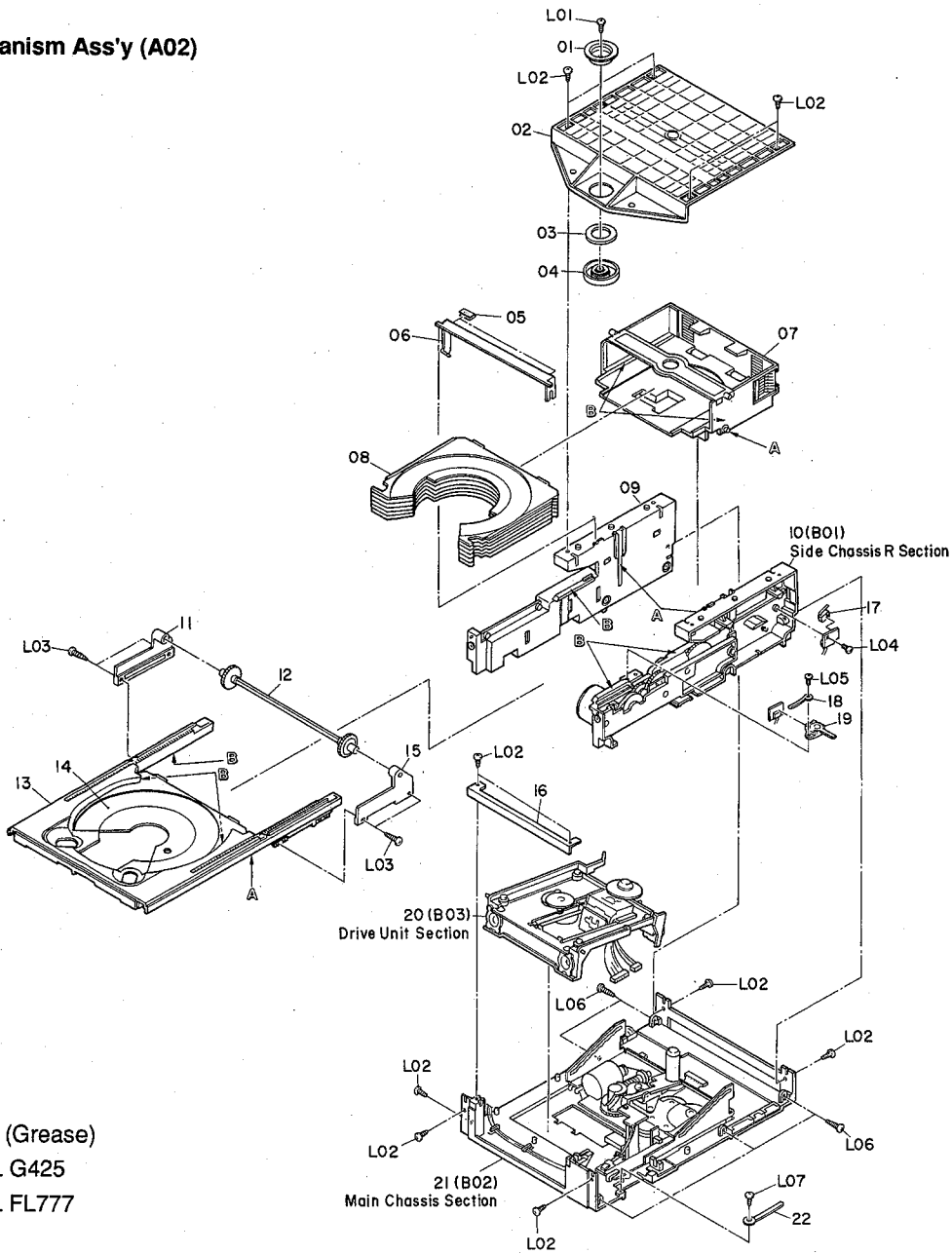
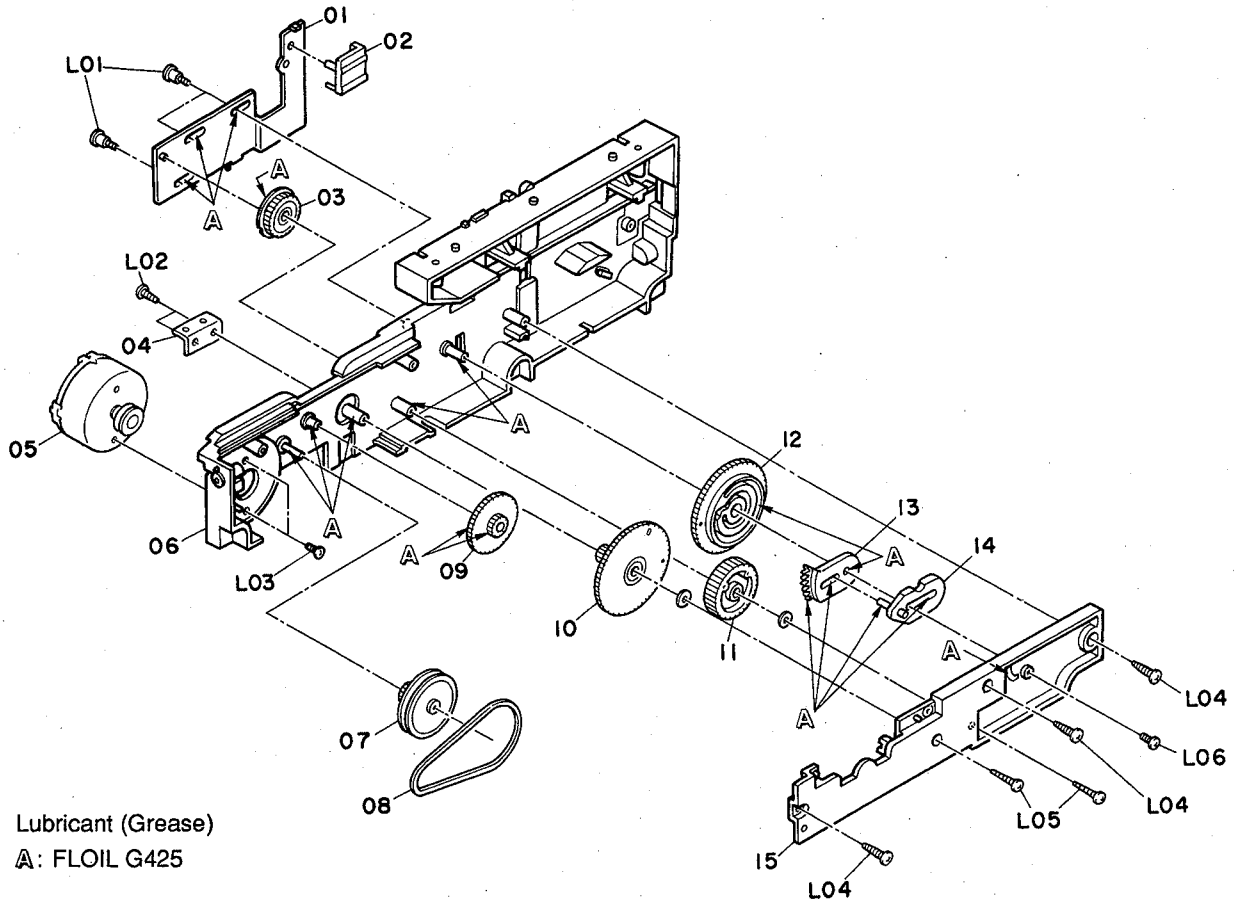

Fig. 7.3

7.3. Mechanism Ass'y

Schematic Ref. No.	Part No.	Description	Q'ty	Schematic Ref. No.	Part No.	Description	Q'ty
A02	CG09210A	Mechanism Ass'y	1	15	2C00097A	Tray Holder R	1
01	2C00014A	Clamper HI	1	16	2C00086A	Mecha B Stopper	1
02	2C00094A	Top Cover	1	17	2B70009A	Store Switch MSS-10L2-1	1
03	2C00016A	Magnet 17x27x5	1	18	2C00107A	Wire Clamper 3B40	1
04	2C00015A	Clamper LO	1	19	2B70007A	Eject /T-Close Switch SSS-13	1
05	2C00101A	A Arm Cushion	1	20	—	Drive Unit Section	1
06	2C00071A	Assist Arm	1	21	—	Main Chassis Section	1
07	CB00215A	Stocker Ass'y	1	22	2C00106A	Wire Clamper 3A60	1
08	2C00012A	Carriage	6	L01	0E03610A	BT2.6x6 + Binding (Black Chromate)	1
09	2C00090A	Side Chassis L	1	L02	0E00825A	BT2.6x8 + Binding (Black Chromate)	1
10	—	Side Chassis R Section	1	L03	2E00005A	M2.6x12 + Binding	1
11	2C00098A	Tray Holder L	1	L04	0E00961A	BT2x5 + Binding	1
12	CB00230A	Timing Ass'y	1	L05	0E03442A	ST2.6x5 + Pan	1
13	CB00214A	Tray Ass'y	1	L06	0E03612A	BT2.6x10 + Binding (Black Chromate)	1
14	2C00013A	Carriage S	1	L07	0E00873A	BT2.6x5 + Binding	1

7.4. Side Chassis R Section (B01)



Lubricant (Grease)
A: FLOIL G425

Fig. 7.4

7.4. Side Chassis R Section

Schematic Ref. No.	Part No.	Description	Q'ty
B01	—	Side Chassis R Section	1
01	CB00223A	Change Plate Ass'y	1
02	2C00072A	Carriage Opener	1
03	2C00039A	Change Gear	1
04	2C00093A	SW-Bracket	1
05	CB00216A	Loading Motor Ass'y	1
06	CB00222A	Side Chassis R Sub Ass'y	1
07	2C00044A	S-P-Gear	1
08	2C00017A	Belt-C-S	1
09	2C00041A	Side Idler	1
10	2C00054A	S-F-Gear	1
11	2C00042A	S-I-Gear	1
12	2C00043A	S-M-Gear	1
13	2C00045A	Tray Stopper	1
14	CB00225A	Tray Arm Ass'y	1
15	2C00040A	Gear Holder	1
L01	2E00002A	BT2.0x1.4x5.9	
L02	0E03610A	BT2.6x6 + Binding (Black Chromate)	
L03	0E00945A	M2.6x4 + Binding (Black Chromate)	
L04	0E00825A	BT2.6x8 + Binding (Black Chromate)	
L05	0E03756A	BT2x10 + Binding (Black Chromate)	
L06	2E00013A	M2x4 + Binding (Black Chromate)	

7.5. Main Chassis Section (B02)

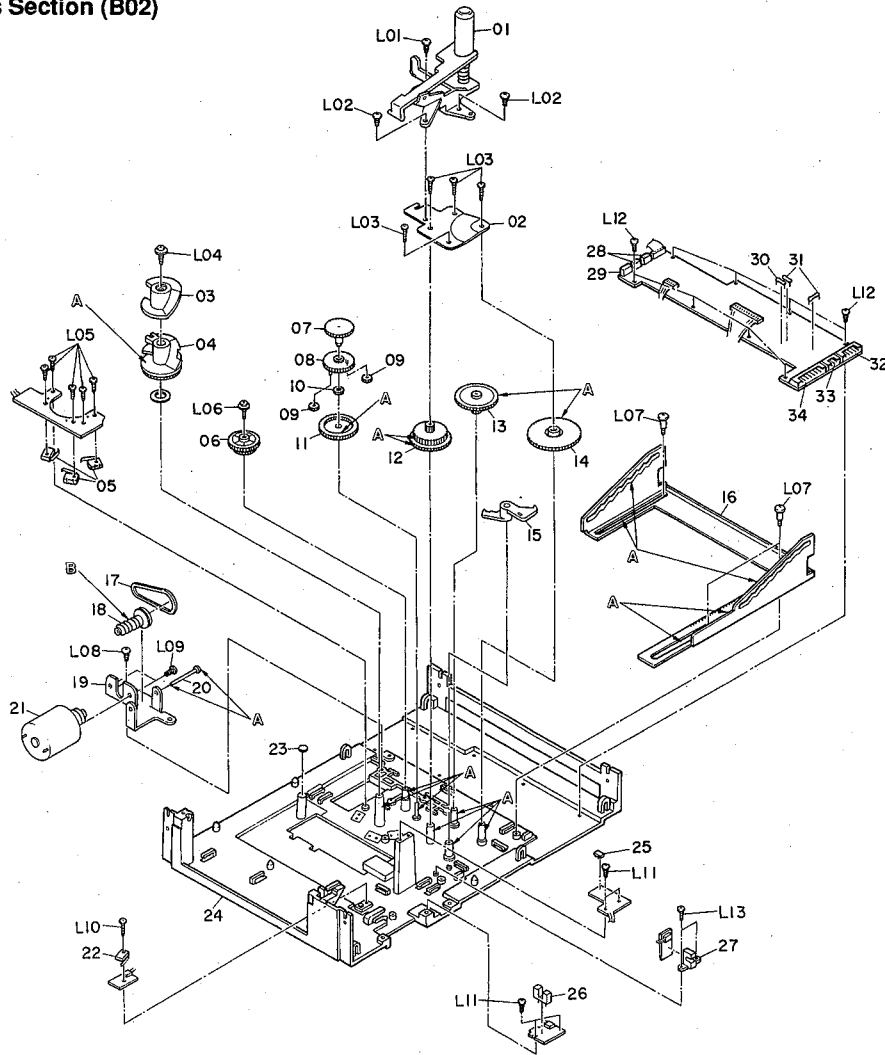

Lubricant (Grease)
A: FLOIL G425
B: FLOIL FL777

Fig. 7.5

7.5. Main Chassis Section

Schematic Ref. No.	Part No.	Description	Q'ty	Schematic Ref. No.	Part No.	Description	Q'ty
B02	—	Main Chassis Section	1	27	2B10020A	Photo Interrupter GS1S51V	1
01	CB00224A	Disc Lock Arm Ass'y	1	28	0B81459A	B2B-PH-K-S	2
02	2C00081A	Gear Plate	1	29	0B81460A	B3B-PH-K-S	1
03	2C00085A	ME UD Cam Top	1	30	0B09665A	RK 270 1/ 6WJ	1
04	2C00084A	Mecha UD Cam	1	31	0B09663A	RK 330 1/6W J	2
05	2B70008A	Cam Switch MSS-10R2-16	3	32	0B81470A	S6B-PH-K-S	1
06	2C00082A	ID-ST-Gear	1	33	0B81468A	S4B-PH-K-S	1
07	2C00074A	D1-ST-Gear	1	34	0B84475A	S12B-PH-K-S	1
08	CB00226A	D2-ST-Gear Ass'y	1	L01	0E03610A	BT2.6x6 + Binding (Black Chromate)	
09	2C00075A	D3-ST-Gear	2	L02	0E00945A	M2.6x4 + Binding (Black Chromate)	
10	2C00076A	D4-ST-Gear	1	L03	0E00969A	BT2x8 + Binding	
11	2C00077A	D5-ST-Gear	1	L04	2E00010A	BT3x10 + Binding Washer-Faced	
12	2C00083A	Lock Idler	1	L05	2E00008A	BT1.7x5.5 + Binding	
13	2C00079A	D7-ST-Gear	1	L06	2E00009A	BT2x8 + Binding Washer-Faced	
14	2C00078A	D6-ST-Gear	1	L07	2E00001A	BT2.6x1.4x7.4	
15	2C00073A	Change Arm	1	L08	0E00873A	BT2.6x5 + Binding	
16	2C00091A	Stocker Cam	1	L09	0E00501A	M3x3 + Pan	
17	2C00018A	Belt-T-C	1	L10	2E00007A	BT1.7x8 + Binding	
18	2C00092A	ST-Worm-Gear	1	L11	0E00961A	BT2x5 + Binding	
19	2C00088A	Motor Bracket	1	L12	2E00006A	BT1.7x4 + Binding	
20	2C00100A	Worm Shaft	1	L13	0E00869A	BT2.6x4 + Binding	
21	CB00213A	Stocker Motor Ass'y	1	—	2B80006A	Wire CNW-W6P	1
22	2B70012A	Home Position MSS-10R2-17	1	—	2B80007A	Wire CNW-2P175	1
23	2C00099A	Mecha Cushion	2	—	2B80008A	Wire CNW-2P330	1
24	CB00221A	Main Chassis Ass'y	1	—	2B80009A	Wire CNW-W4P	1
25	2B10019A	Photo Reflector GP2S40	1	—	2B80010A	Wire CNW-W2P50	1
26	2B10021A	Photo Interrupter GP1S52V	1	—	2B80011A	Wire CNW-W11P	1
				—	2B80012A	Wire CNW-3P	1

7.6. Drive Unit Section (B03)

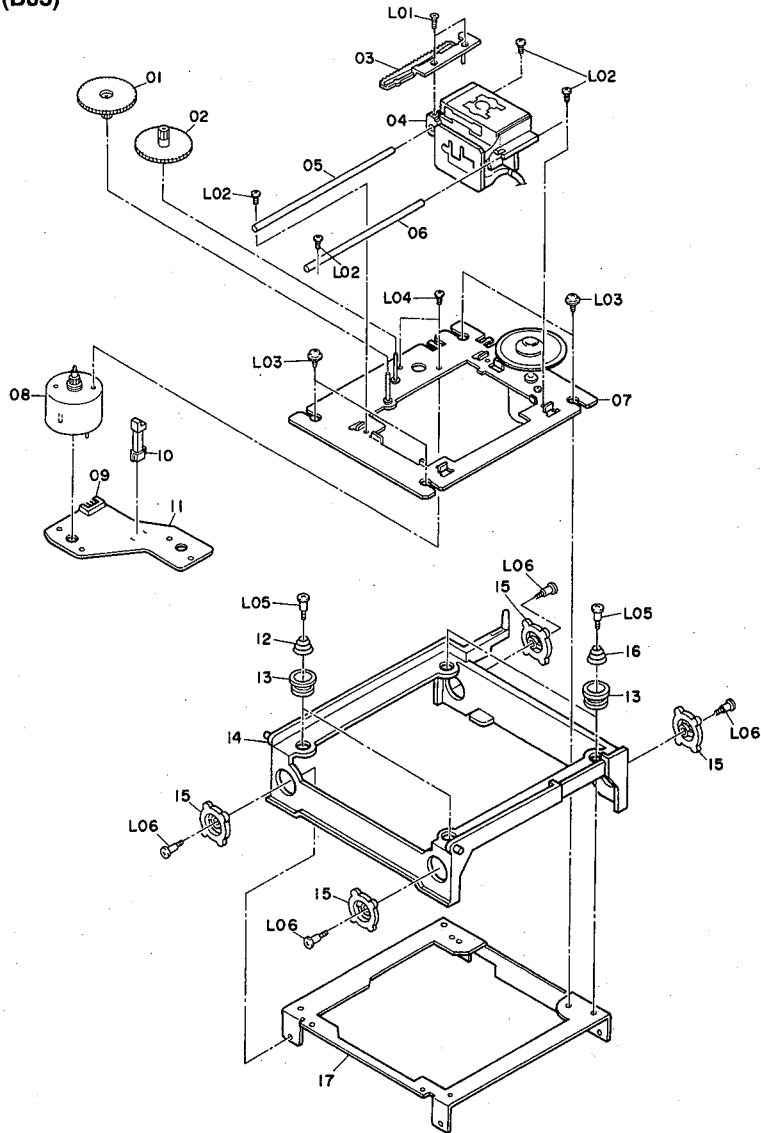

Fig. 7.6

7.6. Drive Unit Section

Schematic Ref. No.	Part No.	Description	Q'ty	Schematic Ref. No.	Part No.	Description	Q'ty
B03	—	Drive Unit Section	1	L02	2E00011A	ST2.6x6 + Binding	
01	2C00023A	Gear Power	1	L03	2E00012A	ST2.6x6 + Cup Screw	
02	2C00022A	Gear Middle	1	L04	0E03439A	M2x2.5 + Pan (Black Chromate)	
03	2C00105A	Plate Rack	1	L05	2E00004A	ST2.0x10x15	
04	2C00019A	Pick-up SF91NC	1	L06	2E00003A	ST2.0x3.0x8.0	
05	2C00021A	Guide Bar B	1				
06	2C00020A	Guide Bar A	1				
07	CB00217A	Disc Motor Ass'y	1				
08	CB00218A	Feed Motor Ass'y	1				
09	0B81470A	6P S-Post S6B-PH	1				
10	2B70011A	Leaf SW BSW-333A	1				
11	2B60002A	Motor P.C.B. 90V1-M	1				
12	2C00027A	Mecha SP B	2				
13	2C00025A	Mecha Limit	4				
14	CB00227A	Mecha Base Ass'y	1				
15	2C00024A	Mecha Sus	4				
16	2C00026A	Mecha SP A	2				
17	2C00087A	Mecha Chassis	1				
L01	0E03648A	M2x5 + Countersunk	1				

8. MOUNTING DIAGRAMS AND PARTS LIST

8.1. Main P.C.B. Ass'y

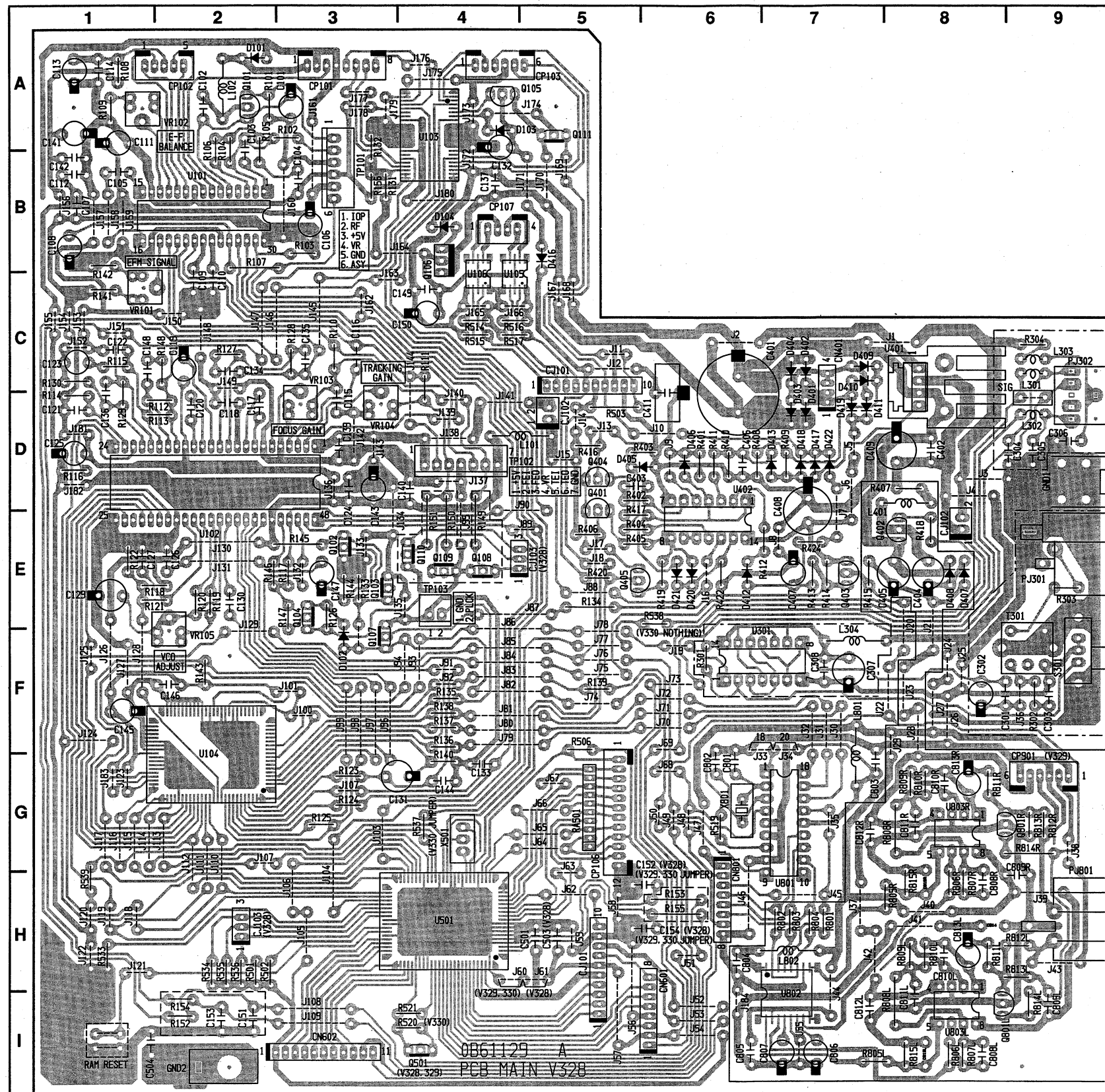

Fig. 8.1

•Semiconductor Location

Ref. No.	Location
U101	B-2
U102	D-2
U103	A-4
U104	G-2
U105	C-4
U106	C-4
U301	F-6
U401	C-8
U402	E-6
U501	H-4
U801	G-7
U802	I-7
U803L	I-8
U803R	G-8
Q101	A-2
Q102	E-3
Q103	E-3
Q104	E-3
Q105	A-4
Q106	B-4
Q107	F-3
Q108	E-4
Q109	E-4
Q110	E-4
Q111	A-5
Q401	D-5
Q402	E-8
Q403	E-7
Q404	D-5
Q405	E-5
Q501	I-4
Q801L	I-9
Q801R	G-9
D101	A-2
D102	F-3
D103	A-4
D104	B-4
D401	D-7
D402	C-7
D403	D-7
D404	C-7
D405	D-5
D406	D-6
D407	E-8
D408	E-8
D409	C-7
D410	C-7
D411	D-7
D412	E-6
D413	D-7
D416	B-5
D417	D-7
D418	D-7
D419	D-7
D420	E-6
D421	E-6
D422	D-7

8.2. Transformer P.C.B. Ass'y

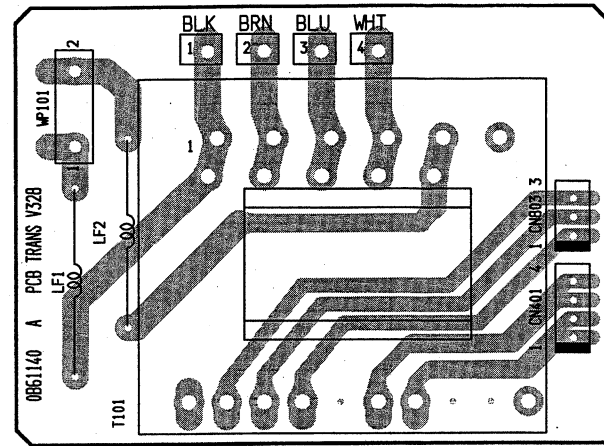

Fig. 8.2

8.3. Power Switch P.C.B. Ass'y

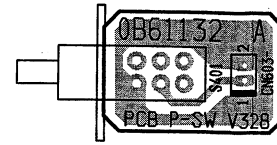

Fig. 8.3

8.7. DAC P.C.B. Ass'y (MB-1s)

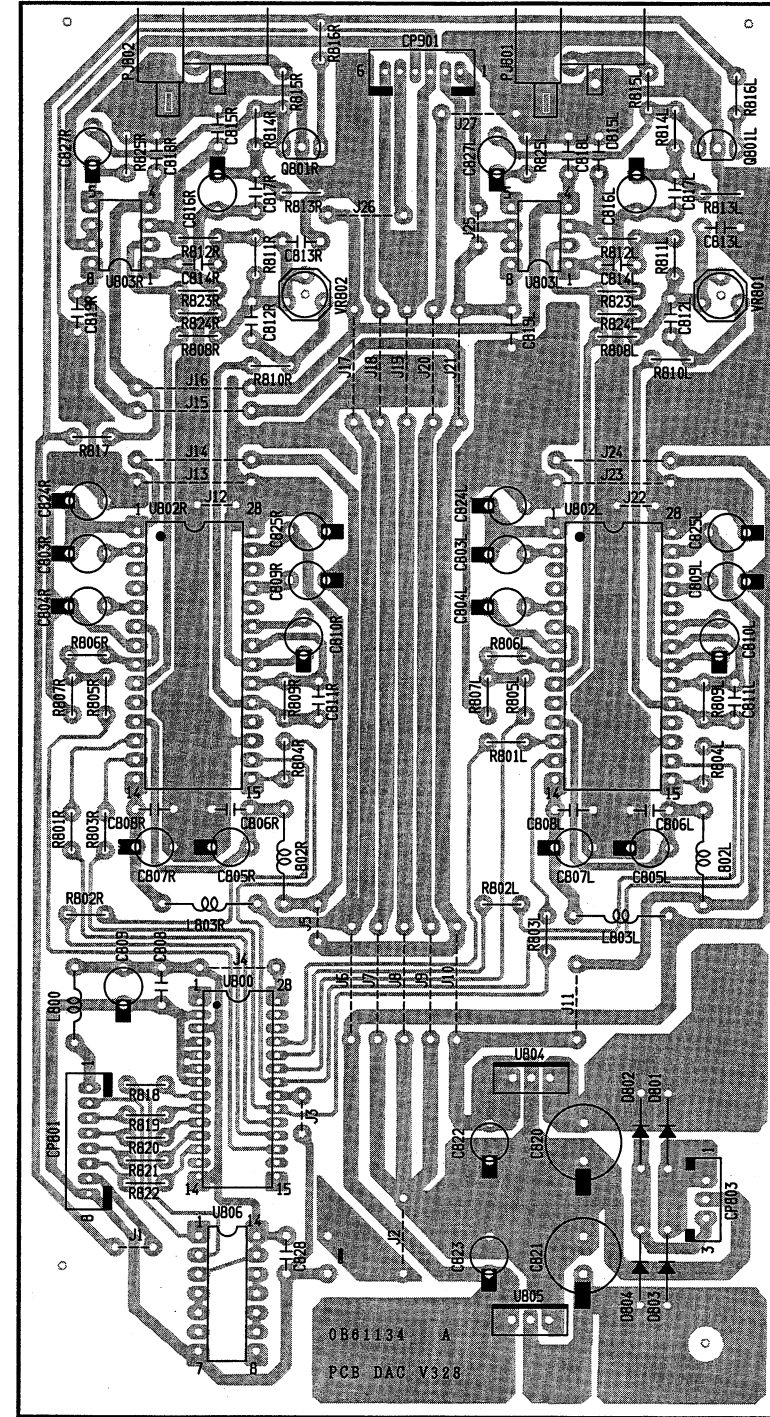

Fig. 8.7 (MB-1s)

8.4. Key P.C.B. Ass'y

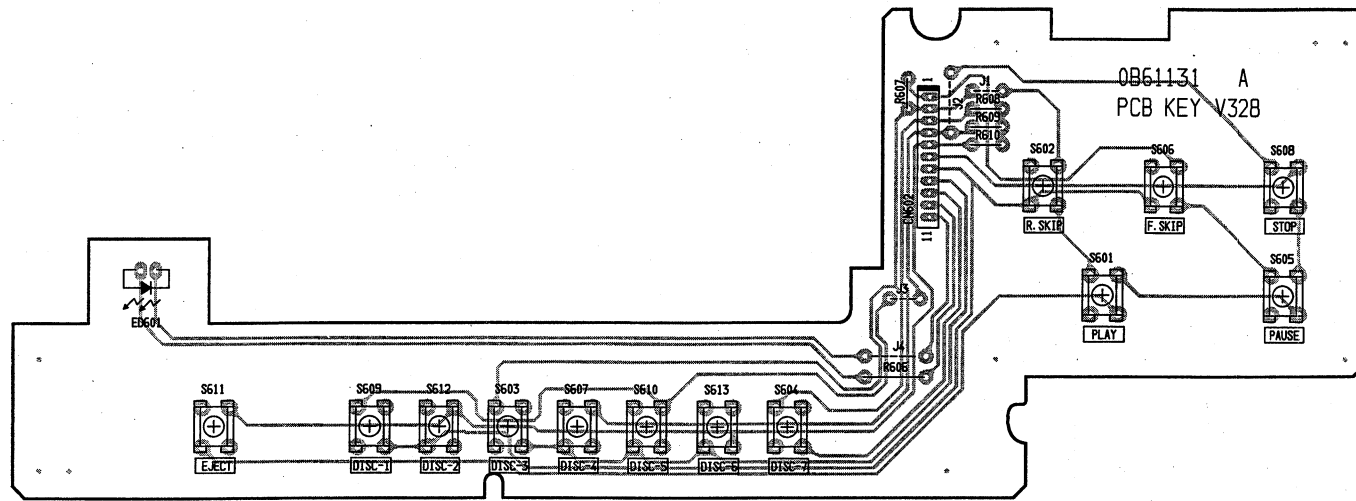

Fig. 8.4

8.5. Display P.C.B. Ass'y

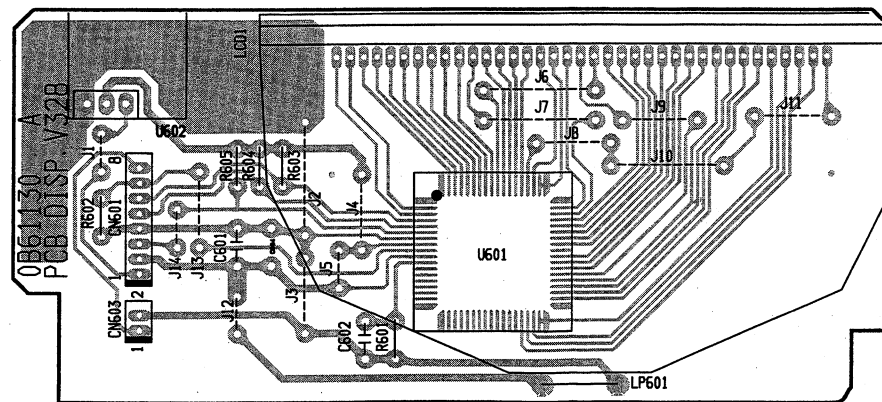

Fig. 8.5

8.6. Headphone P.C.B. Ass'y (MB-1s and -2s)

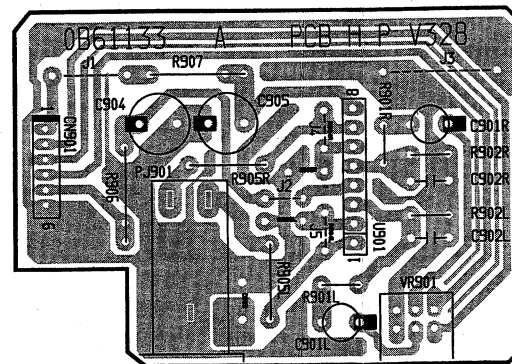

Fig. 8.6 (MB-1s and -2s)

MB-1s Electrical Parts list (1/2)

NOTES: 1. Abbreviations

TR – Transistor, SID – Silicon Diode, ZD – Zener Diode, Varicap – Variable Capacitance Diode
 RK – Carbon Resistor, RM – Metal Film Resistor, RF – Fail Safe Type Resistor,
 RC – Cement Resistor, CE – Electrolytic Capacitor, CML – Mylar Capacitor,
 CC – Ceramic Capacitor, CPP – PP Capacitor, CMM – Metalized Mylar Capacitor,
 CSP – Polystyrene Capacitor, C – Mica Capacitor, CT – Tantalum Capacitor

2. Description of capacitor: 10 16V = 10µ 16V

3. Parts marked with * show chip parts.

8.1. Main P.C.B. Ass'y

Schematic Ref. No.	Part No.	Description	Schematic Ref. No.	Part No.	Description	Schematic Ref. No.	Part No.	Description
	BA09068A	Main P.C.B. Ass'y	R117	0B09713A	RK 33K 1/6W J	R534,535	0B09717A	RK 47K 1/6W J
			R118	0B25291A	RM 10K 1/4W F	R536	0B09717A	RK 47K 1/6W J
			R119	0B25666A	RM 3.6K 1/4W F	R537	0B09677A	RK 1K 1/6W J
			R120	0B09734A	RK 240K 1/6W J	R538	0B09701A	RK 10K 1/6W J
U101	0B11818A	IC CXA1081S	R121	0B09701A	RK 10K 1/6W J	R539	0B09725A	RK 100K 1/6W J
U102	0B11819A	IC CXA1082BS	R122	0B25291A	RM 10K 1/4W F	R540,541	0B09701A	RK 10K 1/6W J
U103	0B10558A	IC BA6296FP	R123	0B09721A	RK 68K 1/6W J	C101	0B40063A	CE 100 10V
U104	0B11946A	IC CXD1167Q	R124	0B09701A	RK 10K 1/6W J	C102	0B41944A	CC 1000P 50V K
U105,106	0B10465A	IC LB1638M	R125,126	0B09725A	RK 100K 1/6W J	C103	0B41521A	CML 3300P 50V J
U301	0B11564A	IC TC74HC00AP	R127	0B09737A	RK 330K 1/6W J	C104	0B41708A	CC 22P 50V J
U401	0B10554A	IC PQ05RF1	R128	0B09729A	RK 150K 1/6W J	C105	0B41294A	CML 0.047 50V J
U402	0B11611A	IC TC4584BP	R129	0B09720A	RK 62K 1/6W J	C106	0B40076A	CE 33 16V
U501	0B10556A	IC UPD75517-230	R130	0B09704A	RK 13K 1/6W J	C107	0B47137A	CC 0.047 25V Z
U801	0B10551A	IC SM5841CP	R131	0B09710A	RK 24K 1/6W J	C108	0B40111A	CE 0.47 50V
Q101	0B10097A	TR 2SA952	R132	0B09701A	RK 10K 1/6W J	C109	0B41522A	CML 4700P 50V J
Q102	0B10068A	TR DTC114ES	R133	0B09725A	RK 100K 1/6W J	C110	0B41525A	CML 0.015 50V J
Q103,104	0B10368A	TR DTC144TS	R134	0B09701A	RK 10K 1/6W J	C111	0B40076A	CE 33 16V
Q105,106	0B10563A	TR 2SB1482	R135	0B09677A	RK 1K 1/6W J	C112	0B47133A	CC 0.01 50V Z
Q107,108	0B10368A	TR DTC144TS	R136,137	0B09653A	RK 100 1/6W J	C113	0B40114A	CE 3.3 50V
Q109,110	0B10368A	TR DTC144TS	R138,139	0B09653A	RK 100 1/6W J	C114	0B47137A	CC 0.047 25V Z
Q111	0B10058A	TR DTA114ES	R140	0B09749A	RK 1M 1/6W J	C115,116	0B41278A	CML 2200P 50V J
Q401	0B06100A	TR 2SC945	R141,142	0B09705A	RK 15K 1/6W J	C117	0B41298A	CML 0.1 50V J
Q403	0B10094A	TR 2SA1015 (Y)	R143	0B09701A	RK 10K 1/6W J	C118	0B41294A	CML 0.047 50V J
Q404,405	0B06100A	TR 2SC945	R144	0B09713A	RK 33K 1/6W J	C119	0B40115A	CE 4.7 50V
Q501	0B10068A	TR DTC114ES	R145	0B09701A	RK 10K 1/6W J	C120	0B41298A	CML 0.1 50V J
D101,102	0B06398A	SID 1SS176	R146,147	0B09713A	RK 33K 1/6W J	C121	0B41823A	CML 0.01 50V J
D103,104	0B06398A	SID 1SS176	R148	0B09731A	RK 180K 1/6W J	C122	0B41298A	CML 0.1 50V J
D401,402	0B12693A	SID S5688B	R149	0B09697A	RK 6.8K 1/6W J	C123	0B09163A	CE 10 16V (BP)
D403,404	0B12693A	SID S5688B	R150	0B09708A	RK 20K 1/6W J	C124	0B47117A	CC 0.1 50V Z
D405,406	0B06398A	SID 1SS176	R151	0B09701A	RK 10K 1/6W J	C125	0B40076A	CE 33 16V
D409,410	0B06398A	SID 1SS176	R152,153	0B09709A	RK 22K 1/6W J	C126	0B41298A	CML 0.1 50V J
D411	0B12693A	SID S5688B	R154,155	0B09709A	RK 22K 1/6W J	C127	0B41974A	CC 100P 50V J
D412,413	0B06398A	SID 1SS176	R156	0B09701A	RK 10K 1/6W J	C129	0B40078A	CE 100 16V
D416,417	0B06398A	SID 1SS176	R157	0B09697A	RK 6.8K 1/6W J	C130	0B41274A	CML 1000P 50V J
D418	0B06398A	SID 1SS176	R158	0B09701A	RK 10K 1/6W J	C131	0B40111A	CE 0.47 50V
D419	0B12693A	SID S5688B	R301	0B09701A	RK 10K 1/6W J	C132	0B40063A	CE 100 10V
D420,421	0B06398A	SID 1SS176	R302	0B09655A	RK 120 1/6W J	C133	0B41823A	CML 0.01 50V J
D422	0B06398A	SID 1SS176	R303	0B09650A	RK 75 1/6W J	C134	0B41283A	CML 5600P 50V J
T101	0B51351A	Pulse Transformer	R304	0B09637A	RK 22 1/6W J	C135	0B41885A	CC 220P 50V J
L101,102	0B51369A	Inductor 10uH	R401	0B09749A	RK 1M 1/6W J	C136	0B41823A	CML 0.01 50V J
L301,302	0B51311A	Inductor 100uH	R402	0B09701A	RK 10K 1/6W J	C137	0B47117A	CC 0.1 50V Z
L303	0B51311A	Inductor 100uH	R403	0B09749A	RK 1M 1/6W J	C139,140	0B47133A	CC 0.01 50V Z
L304	0B51369A	Inductor 10uH	R404	0B09701A	RK 10K 1/6W J	C141	0B40076A	CE 33 16V
L801	0B51369A	Inductor 10uH	R405	0B09717A	RK 47K 1/6W J	C142	0B47133A	CC 0.01 50V Z
X501	0B92033A	Crystal 4.0MHz	R406	0B09693A	RK 4.7K 1/6W J	C143	0B40074A	CE 10 16V
X801	0B92039A	X'tal 16.9344MHz	R408,409	0B09701A	RK 10K 1/6W J	C144	0B41526A	CML 0.018 50V J
VR101	0B32145A	Semi VR 10K	R410	0B09749A	RK 1M 1/6W J	C145	0B40078A	CE 100 16V
VR102,103	0B32146A	Semi VR 20K	R411	0B09701A	RK 10K 1/6W J	C146	0B47117A	CC 0.1 50V Z
VR104	0B32146A	Semi VR 20K	R412	0B09677A	RK 1K 1/6W J	C147	0B40115A	CE 4.7 50V
VR105	0B30170A	Semi VR 1K	R413	0B09718A	RK 51K 1/6W J	C148	0B41525A	CML 0.015 50V J
RA501	0B20656A	R Array 47Kx9	R414	0B09701A	RK 10K 1/6W J	C149	0B47117A	CC 0.1 50V Z
R101	0B09629A	RK 10 1/6W J	R416	0B09693A	RK 4.7K 1/6W J	C150	0B40063A	CE 100 10V
R102	0B09677A	RK 1K 1/6W J	R417	0B09717A	RK 47K 1/6W J	C151	0B41298A	CML 0.1 50V J
R103	0B09701A	RK 10K 1/6W J	R419	0B09717A	RK 47K 1/6W J	C152	0B41294A	CML 0.047 50V J
R104	0B09699A	RK 8.2K 1/6W J	R420	0B09701A	RK 10K 1/6W J	C153	0B41298A	CML 0.1 50V J
R105	0B09685A	RK 2.2K 1/6W J	R422	0B09717A	RK 47K 1/6W J	C154	0B41294A	CML 0.047 50V J
R106	0B09699A	RK 8.2K 1/6W J	R424	0B09653A	RK 100 1/6W J	C155	0B41885A	CC 220P 50V J
R107	0B09725A	RK 100K 1/6W J	R501,502	0B09701A	RK 10K 1/6W J	C301	0B41823A	CML 0.01 50V J
R108	0B09677A	RK 1K 1/6W J	R503	0B09701A	RK 10K 1/6W J	C302	0B40076A	CE 33 16V
R109	0B09709A	RK 22K 1/6W J	R506	0B09713A	RK 33K 1/6W J	C303	0B47109A	CC 47P 50V J
R110,111	0B09701A	RK 10K 1/6W J	R514,515	0B09725A	RK 100K 1/6W J	C304,305	0B47215A	CC 330P 50V J
R112	0B09731A	RK 180K 1/6W J	R516,517	0B09725A	RK 100K 1/6W J	C306	0B47117A	CC 0.1 50V Z
R113	0B09735A	RK 270K 1/6W J	R519	0B09725A	RK 100K 1/6W J	C307	0B40078A	CE 100 16V
R114	0B09742A	RK 510K 1/6W J	R521	0B09725A	RK 100K 1/6W J	C308	0B47117A	CC 0.1 50V Z
R115	0B09719A	RK 56K 1/6W J	R533	0B09725A	RK 100K 1/6W J	C401	0B40085A	CE 4700 16V
R116	0B09725A	RK 100K 1/6W J						

MB-1s Electrical Parts list (2/2)

Schematic Ref. No.	Part No.	Description
C402	0B41298A	CML 0.1 50V J
C403	0B41300A	CML 0.15 50V J
C406	0B41823A	CML 0.01 50V J
C407	0B40074A	CE 10 16V
C408	0B40082A	CE 1000 16V
C409	0B40052A	CE 470 6.3V
C411	0B42054A	Gold Cap 0.22F 5.5V
C412	0B41298A	CML 0.1 50V J
C501	0B47117A	CC 0.1 50V Z
C503	0B47117A	CC 0.1 50V Z
C504,505	0B47133A	CC 0.01 50V Z
C506	0B47133A	CC 0.01 50V Z
C801,802	0B41975A	CC 10P 50V C
C803	0B47117A	CC 0.1 50V Z
CJ101	0B80638B	Ribbon Cable 10P
CJ102	0B80639B	Ribbon Cable 2P
CJ103	0B80656A	3P Ribbon Cable
CN103	0B80642A	Connector Ass'y CN103
CN106	0B80643A	Connector Ass'y CN106
CN107	0B80644A	Connector Ass'y CN107
CN401	0B80658A	4P Connector Ass'y
CN601	0B80631B	Connector Ass'y CN601
CN602	0B80632A	Connector Ass'y CN602
CN801	0B80636A	Connector Ass'y
CP101	0B81465A	8P T-Post
CP102	0B81462A	5P T-Post
CP103	0B81463A	6P T-Post
CP106	0B84087A	12P T-Post
CP107	0B81461A	4P T-Post
S301	0B70165A	Slide Switch
TP101	0B08182A	6P T-Post
TP102	0B02244A	7P T-Post
TP103	0B02233A	2P T-Post
PJ301	0B84544A	1P Pin Jack
PJ302	0B84028A	Stereo Mini
GND1	0B84388A	Screw Terminal
GND2	0J05898C	Earth Plate
	0B80657A	Lead Wire (1)
	0B80659A	Lead Wire (1)
	0B90019A	SK Binder SKB80 (6)
	0B90464A	Heat Sink (1)

8.2. Transformer P.C.B. Ass'y

Schematic Ref. No.	Part No.	Description
		Transformer P.C.B. Ass'y
	0B61140A	Transformer P.C.B.
LF1,2	0B51397A	Inductor 15uH VW1
WP101	0B84275A	Wrapping Terminal 2P
CN803	0B80635B	Connector Ass'y CN803
	0B90366A	Fuse Clip (FP-217) (2)

8.3. Power Switch P.C.B. Ass'y

Schematic Ref. No.	Part No.	Description
	BA09071A	Power Switch P.C.B. Ass'y
	0B61132A	Power Switch P.C.B.
S401	0B70226A	Push Switch

8.4. Key P.C.B. Ass'y

Schematic Ref. No.	Part No.	Description
	BA09070A	Key P.C.B. Ass'y
	0B61131A	Key P.C.B.
R607,608	0B09717A	RK 47K 1/6W J
R609,610	0B09717A	RK 47K 1/6W J
S601,602	0B70227A	Tact Switch LCP-S
S603,604	0B70227A	Tact Switch LCP-S
S605,606	0B70227A	Tact Switch LCP-S
S607,608	0B70227A	Tact Switch LCP-S
S609,610	0B70227A	Tact Switch LCP-S
S611,612	0B70227A	Tact Switch LCP-S
S613	0B70227A	Tact Switch LCP-S

8.5. Display P.C.B. Ass'y

Schematic Ref. No.	Part No.	Description
	BA09069A	Display P.C.B. Ass'y
	0B61130A	Display P.C.B.
U601	0B11891A	IC LC7582A
U602	0B10555A	Remote Control Sensor GP1U581Y
R601	0B09717A	RK 47K 1/6W J
R602,603	0B09725A	RK 100K 1/6W J
R604,605	0B09725A	RK 100K 1/6W J
C601	0B47117A	CC 0.1 50V Z
C602	0B05571A	CML 680P 50V J
CN603	0B80633B	Connector Ass'y CN603
LCD1	0B90641A	LCD GTD-12743AA
LP601	0B90640A	Lamp 200mA 5V

8.6. Headphone P.C.B. Ass'y

Schematic Ref. No.	Part No.	Description
	BA09072A	Headphone P.C.B. Ass'y
	0B61133A	Headphone P.C.B.
U901	0B11857A	IC NJM4556L
VR901	0B30120A	VR 50K(A)x2
R901L,R	0B09677A	RK 1K 1/6W J
R902L,R	0B09717A	RK 47K 1/6W J
R904L,R	0B09701A	RK 10K 1/6W J
R905L,R	0B09643A	RK 39 1/6W J
R906,907	0B24305A	RF 27 1/2W J
C901L,R	0B40074A	CE 10 16V
C902L,R	0B41394A	CPP 220P 50V J
C903L,R	0B47286A	CPP 47P 25V J
C904,905	0B40079A	CE 220 16V
CN901	0B80637A	Connector Ass'y
PJ901	0B84371A	Headphone Jack

8.7. DAC P.C.B. Ass'y

Schematic Ref. No.	Part No.	Description
	BA09074A	DAC P.C.B. Ass'y (USA, CAN, UK, AUS, OTR, JPN)
	BA09188A	DAC P.C.B. Ass'y (EP)
	0B61134A	DAC P.C.B.
U800	0B11824A	IC MB623403
U802L,R	0B11850A	IC PCM1700P
U803L,R	0B11873A	IC NE5532AN
U804	0B11609A	IC NJM78M05FA
U805	0B17001A	IC NJM79M05FA
U806	0B11557A	IC TC74HC04AP
Q801L,R	0B06299A	TR 2SC2878

Schematic Ref. No.	Part No.	Description
D801,802	0B12693A	SID S5688B
D803,804	0B12693A	SID S5688B
L800	0B51126A	Inductor 100uH
L802L,R	0B51369A	Inductor 10mH
L803L,R	0B51369A	Inductor 10mH
VR801,802	0B30169A	Semi VR 200
R801L,R	0B09653A	RK 100 1/6W J
R802L,R	0B09653A	RK 100 1/6W J
R803L,R	0B09653A	RK 100 1/6W J
R804L,R	0B09653A	RK 100 1/6W J
R805L,R	0B25471A	RM 750K 1/4W F
R806L,R	0B25387A	RM 100K 1/4W F
R807L,R	0B25145A	RM 301 1/4W F
R808L,R	0B25166A	RM 499 1/4W F
R809L,R	0B22644A	RM 1.54K 1/4W F
R810L,R	0B25223A	RM 1.96K 1/4W F
R811L,R	0B25207A	RM 1.33K 1/4W F
R812L,R	0B25216A	RM 1.65K 1/4W F
R813L,R	0B25356A	RM 47.5K 1/4W F
R814L,R	0B25653A	RM 560 1/4W F
R815L,R	0B25099A	RM 100 1/4W F
R816L,R	0B09691A	RK 3.9K 1/6W J
R817	0B09749A	RK 1M 1/6W J
R818,819	0B09653A	RK 100 1/6W J
R820,821	0B09653A	RK 100 1/6W J
R822	0B09653A	RK 100 1/6W J
R823L,R	0B25195A	RM 1K 1/4W F
R824L,R	0B25260A	RM 4.75K 1/4W F
R825L,R	0B09717A	RK 47K 1/6W J
C803L,R	0B40768A	CE 4.7 25V (LN)
C804L,R	0B40768A	CE 4.7 25V (LN)
C805L,R	0B40115A	CE 4.7 50V
C806L,R	0B41176A	CML 0.22 63V J
C807L,R	0B40115A	CE 4.7 50V
C808	0B47117A	CC 0.1 50V Z
C808L,R	0B41176A	CML 0.22 63V J
C809	0B40049A	CE 100 6.3V
C809L,R	0B40768A	CE 4.7 25V (LN)
C810L,R	0B40768A	CE 4.7 25V (LN)
C811L,R	0B41797A	CSP 47P 160V J
C812L,R	0B42118A	CSP 27P 160V J
C813L,R	0B41239A	CPP 3900P 100V J
C814L,R	0B41225A	CPP 1000P 100V J
C815L,R	0B41223A	CPP 820P 100V J
C816L,R	0B40706A	CE 10 25V (LN)
C817L,R	0B41201A	CPP 100P 100V J
C818L,R	0B41298A	CML 0.1 50V J
C819L,R	0B41298A	CML 0.1 50V J
C820,821	0B40082A	CE 1000 16V
C822,823	0B40078A	CE 100 16V
C824L,R	0B40768A	CE 4.7 25V (LN)
C825L,R	0B40768A	CE 4.7 25V (LN)
C826	0B41298A	CML 0.1 50V J
C827L,R	0B40074A	CE 10 16V
C828	0B47117A	CC 0.1 50V Z
CP801	0B81465A	8P T-Post
CP803	0B81460A	3P T-Post
CP901	0B81463A	6P T-Post
IP801	0B11248A	IC Protector ICP-N5 0.25A (EP)
PJ801,802	0B80650A	1P Pin Jack (BLK)

MB-2s Electrical Parts list (1/2)

8.1. Main P.C.B. Ass'y

Schematic			Schematic			Schematic		
Ref. No.	Part No.	Description	Ref. No.	Part No.	Description	Ref. No.	Part No.	Description
	BA09076A	Main P.C.B. Ass'y	R120	0B09734A	RK 240K 1/6W J	R810L,R	0B09697A	RK 6.8K 1/6W J
	0B61129A	Main P.C.B.	R121	0B09701A	RK 10K 1/6W J	R811L,R	0B09671A	RK 560 1/6W J
U101	0B11818A	IC CXA1081S	R122	0B25291A	RM 10K 1/4W F	R812L,R	0B09653A	RK 100 1/6W J
U102	0B11819A	IC CXA1082BS	R123	0B09721A	RK 68K 1/6W J	R813L,R	0B09725A	RK 100K 1/6W J
U103	0B10558A	IC BA6296FP	R124	0B09701A	RK 10K 1/6W J	R814L,R	0B09691A	RK 3.9K 1/6W J
U104	0B11946A	IC CXD1167Q	R125,126	0B09725A	RK 100K 1/6W J	R815L,R	0B25308A	RM 15K 1/4W F
U105,106	0B10465A	IC LB1638M	R127	0B09737A	RK 330K 1/6W J	C101	0B40063A	CE 100 10V
U301	0B11564A	IC TC74HC00AP	R128	0B09729A	RK 150K 1/6W J	C102	0B41944A	CC 1000P 50V K
U401	0B10554A	IC PQ05RF1	R129	0B09720A	RK 62K 1/6W J	C103	0B41521A	CML 3300P 50V J
U402	0B11611A	IC TC4584BP	R130	0B09704A	RK 13K 1/6W J	C104	0B41708A	CC 22P 50V J
U501	0B10556A	IC UPD75517-230	R131	0B09710A	RK 24K 1/6W J	C105	0B41294A	CML 0.047 50V J
U801	0B10551A	IC SM5841CP	R132	0B09701A	RK 10K 1/6W J	C106	0B40076A	CE 33 16V
U802	0B17010A	IC AD1868R-J (DAC)	R133	0B09725A	RK 100K 1/6W J	C107	0B47137A	CC 0.047 25V Z
U803L,R	0B06146A	IC NJM4558DD	R134	0B09701A	RK 10K 1/6W J	C108	0B40111A	CE 0.47 50V
Q101	0B10097A	TR 2SA952	R135	0B09677A	RK 1K 1/6W J	C109	0B41522A	CML 4700P 50V J
Q102	0B10068A	TR DTC114ES	R136,137	0B09653A	RK 100 1/6W J	C110	0B41525A	CML 0.015 50V J
Q103,104	0B10368A	TR DTC144TS	R138,139	0B09653A	RK 100 1/6W J	C111	0B40076A	CE 33 16V
Q105,106	0B10563A	TR 2SB1482	R140	0B09749A	RK 1M 1/6W J	C112	0B47133A	CC 0.01 50V Z
Q107	0B10368A	TR DTC144TS	R141,142	0B09705A	RK 15K 1/6W J	C113	0B40114A	CE 3.3 50V
Q111	0B10058A	TR DTA114ES	R143	0B09701A	RK 10K 1/6W J	C114	0B47137A	CC 0.047 25V Z
Q401	0B06100A	TR 2SC945	R144	0B09713A	RK 33K 1/6W J	C115,116	0B41278A	CML 2200P 50V J
Q402	0B06322A	TR 2SC2002	R145	0B09701A	RK 10K 1/6W J	C117	0B41298A	CML 0.1 50V J
Q403	0B10094A	TR 2SA1015 (Y)	R146,147	0B09713A	RK 33K 1/6W J	C118	0B41294A	CML 0.047 50V J
Q404,405	0B06100A	TR 2SC945	R148	0B09731A	RK 180K 1/6W J	C119	0B40115A	CE 4.7 50V
Q501	0B10068A	TR DTC114ES	R156	0B09701A	RK 10K 1/6W J	C120	0B41298A	CML 0.1 50V J
Q801L,R	0B06299A	TR 2SC2878	R157	0B09697A	RK 6.8K 1/6W J	C121	0B41823A	CML 0.01 50V J
D101,102	0B06398A	SID 1SS176	R158	0B09701A	RK 10K 1/6W J	C122	0B41298A	CML 0.1 50V J
D103,104	0B06398A	SID 1SS176	R301	0B09701A	RK 10K 1/6W J	C123	0B09163A	CE 10 16V (BP)
D401,402	0B12693A	SID S5688B	R302	0B09655A	RK 120 1/6W J	C124	0B47117A	CC 0.1 50V Z
D403,404	0B12693A	SID S5688B	R303	0B09650A	RK 75 1/6W J	C125	0B40076A	CE 33 16V
D405,406	0B06398A	SID 1SS176	R304	0B09637A	RK 22 1/6W J	C126	0B41298A	CML 0.1 50V J
D407,408	0B06398A	SID 1SS176	R401	0B09749A	RK 1M 1/6W J	C127	0B41974A	CC 100P 50V J
D409,410	0B06398A	SID 1SS176	R402	0B09701A	RK 10K 1/6W J	C129	0B40078A	CE 100 16V
D411	0B12693A	SID S5688B	R403	0B09749A	RK 1M 1/6W J	C130	0B41274A	CML 1000P 50V J
D412,413	0B06398A	SID 1SS176	R404	0B09701A	RK 10K 1/6W J	C131	0B40111A	CE 0.47 50V
D416,417	0B06398A	SID 1SS176	R405	0B09717A	RK 47K 1/6W J	C132	0B40063A	CE 100 10V
D418	0B06398A	SID 1SS176	R406	0B09693A	RK 4.7K 1/6W J	C133	0B41823A	CML 0.01 50V J
D419	0B12693A	SID S5688B	R407	0B09629A	RK 10 1/6W J	C134	0B41283A	CML 5600P 50V J
D420,421	0B06398A	SID 1SS176	R408,409	0B09701A	RK 10K 1/6W J	C135	0B41885A	CC 220P 50V J
D422	0B06398A	SID 1SS176	R410	0B09749A	RK 1M 1/6W J	C136	0B41823A	CML 0.01 50V J
T101	0B51351A	Pulse Transformer	R411	0B09701A	RK 10K 1/6W J	C137	0B47117A	CC 0.1 50V Z
L101,102	0B51369A	Inductor 10uH	R412	0B09677A	RK 1K 1/6W J	C139,140	0B47133A	CC 0.01 50V Z
L301,302	0B51311A	Inductor 100uH	R413	0B09718A	RK 51K 1/6W J	C141	0B40076A	CE 33 16V
L303	0B51311A	Inductor 100uH	R414	0B09701A	RK 10K 1/6W J	C142	0B47133A	CC 0.01 50V Z
L304	0B51369A	Inductor 10uH	R415	0B09749A	RK 1M 1/6W J	C143	0B40074A	CE 10 16V
L401	0B51132A	Inductor 330uH	R416	0B09693A	RK 4.7K 1/6W J	C144	0B41526A	CML 0.18 50V J
L801,802	0B51369A	Inductor 10uH	R417	0B09717A	RK 47K 1/6W J	C145	0B40078A	CE 100 16V
X501	0B92033A	Crystal 4.0MHz	R418	0B09685A	RK 2.2K 1/6W J	C146	0B47117A	CC 0.1 50V Z
X801	0B92039A	X'tal 16.9344MHz	R419	0B09717A	RK 47K 1/6W J	C147	0B40115A	CE 4.7 50V
VR101	0B32145A	Semi VR 10K	R420	0B09701A	RK 10K 1/6W J	C148	0B41525A	CML 0.015 50V J
VR102,103	0B32146A	Semi VR 20K	R422	0B09717A	RK 47K 1/6W J	C149	0B47117A	CC 0.1 50V Z
VR104	0B32146A	Semi VR 20K	R424	0B09653A	RK 100 1/6W J	C150	0B40063A	CE 100 10V
VR105	0B30170A	Semi VR 1K	R501,502	0B09701A	RK 10K 1/6W J	C155	0B41885A	CC 220P 50V J
RA501	0B20656A	R Array 47Kx9	R503	0B09701A	RK 10K 1/6W J	C301	0B41823A	CML 0.01 50V J
R101	0B09629A	RK 10 1/6W J	R506	0B09713A	RK 33K 1/6W J	C302	0B40076A	CE 33 16V
R102	0B09677A	RK 1K 1/6W J	R514,515	0B09725A	RK 100K 1/6W J	C303	0B41709A	CC 47P 50V J
R103	0B09701A	RK 10K 1/6W J	R516,517	0B09725A	RK 100K 1/6W J	C304,305	0B47215A	CC 330P 50V J
R104	0B09699A	RK 8.2K 1/6W J	R519	0B09725A	RK 100K 1/6W J	C306	0B47117A	CC 0.1 50V Z
R105	0B09685A	RK 2.2K 1/6W J	R521	0B09725A	RK 100K 1/6W J	C307	0B40078A	CE 100 16V
R106	0B09699A	RK 8.2K 1/6W J	R533	0B09725A	RK 100K 1/6W J	C308	0B47117A	CC 0.1 50V Z
R107	0B09725A	RK 100K 1/6W J	R534,535	0B09717A	RK 47K 1/6W J	C401	0B40085A	CE 4700 16V
R108	0B09677A	RK 1K 1/6W J	R536	0B09717A	RK 47K 1/6W J	C402	0B41298A	CML 0.1 50V J
R109	0B09709A	RK 22K 1/6W J	R537	0B09677A	RK 1K 1/6W J	C403	0B41300A	CML 0.15 50V J
R110,111	0B09701A	RK 10K 1/6W J	R538	0B09701A	RK 10K 1/6W J	C404,405	0B40078A	CE 100 16V
R112	0B09731A	RK 180K 1/6W J	R539	0B09725A	RK 100K 1/6W J	C406	0B41823A	CML 0.01 50V J
R113	0B09735A	RK 270K 1/6W J	R540,541	0B09701A	RK 10K 1/6W J	C407	0B40074A	CE 10 16V
R114	0B09742A	RK 510K 1/6W J	R801,802	0B09661A	RK 220 1/6W J	C408	0B40082A	CE 1000 16V
R115	0B09719A	RK 56K 1/6W J	R803,804	0B09661A	RK 220 1/6W J	C409	0B40052A	CE 470 6.3V
R116	0B09725A	RK 100K 1/6W J	R805L,R	0B25671A	RM 5.6K 1/4W F	C411	0B42054A	Gold Cap 0.22F 5.5V
R117	0B09713A	RK 33K 1/6W J	R806L,R	0B25671A	RM 5.6K 1/4W F	C501	0B47117A	CC 0.1 50V Z
R118	0B25291A	RM 10K 1/4W F	R807L,R	0B25308A	RM 15K 1/4W F	C504,505	0B47133A	CC 0.01 50V Z
R119	0B25666A	RM 3.6K 1/4W F	R808L,R	0B09697A	RK 6.8K 1/6W J	C506	0B47133A	CC 0.01 50V Z
			R809L,R	0B09698A	RK 7.5K 1/6W J	C801,802	0B41975A	CC 10P 50V C

MB-2s Electrical Parts list (2/2)

Schematic

Ref. No.	Part No.	Description
C803,804	0B47117A	CC 0.1 50V Z
C805	0B41298A	CML 0.1 50V J
C806,807	0B40768A	CE 4.7 25V (LN)
C808L,R	0B41201A	CPP 100P 100V J
C809L,R	0B41298A	CML 0.1 50V J
C810L,R	0B41201A	CPP 100P 100V J
C811L,R	0B41215A	CPP 390P 100V J
C812L,R	0B41298A	CML 0.1 50V J
C813L,R	0B40776A	CE 47 16V (LN)
CJ101	0B80638B	Ribbon Cable 10P
CJ102	0B80639B	Ribbon Cable 2P
CN103	0B80642A	Connector Ass'y CN103
CN106	0B80643A	Connector Ass'y CN106
CN107	0B80644A	Connector Ass'y CN107
CN401	0B80634B	Connector Ass'y CN401
CN601	0B80631B	Connector Ass'y CN601
CN602	0B80632A	Connector Ass'y CN602
CP101	0B81465A	8P T-Post
CP102	0B81462A	5P T-Post
CP103	0B81463A	6P T-Post
CP106	0B84087A	12P T-Post
CP107	0B81461A	4P T-Post
CP901	0B81463A	6P T-Post
S301	0B70165A	Slide Switch
TP101	0B08182A	6P T-Post
TP102	0B02244A	7P T-Post
TP103	0B02233A	2P T-Post
PJ301	0B84544A	1P Pin Jack
PJ302	0B84028A	Stereo Mini
PJ801	0B80645A	2P Mount Pin Jack
GND1	0B84388A	Screw Terminal
GND2	0J05898C	Earth Plate
	0B80657A	Lead Wire (1)
	0B80659A	Lead Wire (1)
	0B90019A	SK Binder SKB80 (6)
	0B90464A	Heat Sink (1)

8.2. Transformer P.C.B. Ass'y

Schematic Ref. No.	Part No.	Description
		Transformer P.C.B. Ass'y
	0B61140A	Transformer P.C.B.
LF1,2	0B51397A	Inductor 15uH VW1
WP101	0B84275A	Wrapping Terminal 2P
	0B90366A	Fuse Clip (FP-217) (2)

8.3. Power Switch P.C.B. Ass'y

Schematic Ref. No.	Part No.	Description
		Power Switch P.C.B. Ass'y
	0B61132A	Power Switch P.C.B.
S401	0B70226A	Push Switch

8.4. Key P.C.B. Ass'y

Schematic Ref. No.	Part No.	Description
		Key P.C.B. Ass'y
	0B61131A	Key P.C.B.
R607,608	0B09717A	RK 47K 1/6W J
R609,610	0B09717A	RK 47K 1/6W J
S601,602	0B70227A	Tact Switch LCP-S
S603,604	0B70227A	Tact Switch LCP-S
S605,606	0B70227A	Tact Switch LCP-S
S607,608	0B70227A	Tact Switch LCP-S
S609,610	0B70227A	Tact Switch LCP-S
S611,612	0B70227A	Tact Switch LCP-S
S613	0B70227A	Tact Switch LCP-S

8.5. Display P.C.B. Ass'y

Schematic Ref. No.	Part No.	Description
		Display P.C.B. Ass'y
	0B61130A	Display P.C.B.
U601	0B11891A	IC LC7582A
U602	0B10555A	Remote Control Sensor GP1U581Y
LCD1	0B90641A	LCD GTD-12743AA
R601	0B09717A	RK 47K 1/6W J
R602,603	0B09725A	RK 100K 1/6W J
R604,605	0B09725A	RK 100K 1/6W J
C601	0B47117A	CC 0.1 50V Z
C602	0B05571A	CML 680P 50V J
CN603	0B80633B	Connector Ass'y CN603
LP601	0B90640A	Lamp 200mA 5V

8.6. Headphone P.C.B. Ass'y

Schematic Ref. No.	Part No.	Description
		Headphone P.C.B. Ass'y
	0B61133A	Headphone P.C.B.
U901	0B11857A	IC NJM4556L
VR901	0B30120A	VR 50K(A)x2
R901L,R	0B09677A	RK 1K 1/6W J
R902L,R	0B09717A	RK 47K 1/6W J
R905L,R	0B09650A	RK 75 1/6W J
R906	0B09629A	RK 10 1/6W J
R907	0B24305A	RF 27 1/2W J
C901L,R	0B40074A	CE 10 16V
C902L,R	0B41394A	CPP 220P 50V J
C904	0B40078A	CE 100 16V
C905	0B40053A	CE 1000 6.3V
CN901	0B80637A	Connector Ass'y
PJ901	0B84371A	Headphone Jack

MB-3s Electrical Parts list (1/2)

8.1. Main P.C.B. Ass'y

Schematic Ref. No.	Part No.	Description	Schematic Ref. No.	Part No.	Description	Schematic Ref. No.	Part No.	Description
	BA09078A	Main P.C.B. Ass'y	R125,126	0B09725A	RK 100K 1/6W J	C106	0B40076A	CE 33 16V
			R127	0B09737A	RK 330K 1/6W J	C107	0B47137A	CC 0.047 25V J
			R128	0B09729A	RK 150K 1/6W J	C108	0B40111A	CE 0.47 50V
U101	0B11818A	IC CXA1081S	R129	0B09720A	RK 62K 1/6W J	C109	0B41522A	CML 4700P 50V J
U102	0B11819A	IC CXA1082BS	R130	0B09704A	RK 13K 1/6W J	C110	0B41525A	CML 0.015 50V J
U103	0B10558A	IC BA6296FP	R131	0B09710A	RK 24K 1/6W J	C111	0B40076A	CE 33 16V
U104	0B11946A	IC CXD1167Q	R132	0B09701A	RK 10K 1/6W J	C112	0B47133A	CC 0.01 50V Z
U105,106	0B10465A	IC LB1638M	R133	0B09725A	RK 100K 1/6W J	C113	0B40114A	CE 3.3 50V J
U401	0B10554A	IC PQ05RF1	R134	0B09701A	RK 10K 1/6W J	C114	0B47137A	CC 0.047 50V J
U402	0B11611A	IC TC4584BP	R135	0B09677A	RK 1K 1/6W J	C115,116	0B41278A	CML 2200P 50V J
U501	0B10556A	IC UPD75517-230	R136,137	0B09653A	RK 100 1/6W J	C117	0B41298A	CML 0.1 50V J
U801	0B10551A	IC SM5841CP	R138,139	0B09653A	RK 100 1/6W J	C118	0B41294A	CML 0.047 50V J
U802	0B17010A	IC AD1868R-J (DAC)	R140	0B09749A	RK 1M 1/6W J	C119	0B40115A	CE 4.7 50V
U803L,R	0B06124B	IC NJM4558D	R141,142	0B09705A	RK 15K 1/6W J	C120	0B41298A	CML 0.1 50V J
Q101	0B10097A	TR 2SA952	R143	0B09701A	RK 10K 1/6W J	C121	0B41823A	CML 0.01 50V J
Q102	0B10068A	TR DTC114ES	R144	0B09713A	RK 33K 1/6W J	C122	0B41298A	CML 0.1 50V J
Q103,104	0B10368A	TR DTC144TS	R145	0B09701A	RK 10K 1/6W J	C123	0B09163A	CE 10 16V (BP)
Q105,106	0B10563A	TR 2SB1482	R146,147	0B09713A	RK 33K 1/6W J	C124	0B47117A	CC 0.1 50V Z
Q107	0B10368A	TR DTC144TS	R148	0B09731A	RK 180K 1/6W J	C125	0B40076A	CE 33 16V
Q111	0B10058A	TR DTA114ES	R156	0B09701A	RK 10K 1/6W J	C126	0B41298A	CML 0.1 50V J
Q401	0B06100A	TR 2SC945	R157	0B09697A	RK 6.8K 1/6W J	C127	0B41974A	CC 100P 50V J
Q402	0B06322A	TR 2SC2002	R158	0B09701A	RK 10K 1/6W J	C129	0B40078A	CE 100 16V
Q403	0B10094A	TR 2SA1015 (Y)	R401	0B09749A	RK 1M 1/6W J	C130	0B41274A	CML 1000P 50V J
Q404,405	0B06100A	TR 2SC945	R402	0B09701A	RK 10K 1/6W J	C131	0B40111A	CE 0.47 50V
Q801L,R	0B06299A	TR 2SC2878	R403	0B09749A	RK 1M 1/6W J	C132	0B40063A	CE 100 10V
D101,102	0B06398A	SID 1SS176	R404	0B09701A	RK 10K 1/6W J	C133	0B41823A	CML 0.01 50V J
D103,104	0B06398A	SID 1SS176	R405	0B09717A	RK 47K 1/6W J	C134	0B41283A	CML 5600P 50V J
D401,402	0B12693A	SID S5688B	R406	0B09693A	RK 4.7K 1/6W J	C135	0B41885A	CC 220P 50V J
D403,404	0B12693A	SID S5688B	R407	0B09637A	RK 22 1/6W J	C136	0B41823A	CML 0.01 50V J
D405,406	0B06398A	SID 1SS176	R408,409	0B09701A	RK 10K 1/6W J	C137	0B47117A	CC 0.1 50V Z
D407,408	0B06398A	SID 1SS176	R410	0B09749A	RK 1M 1/6W J	C139,140	0B47133A	CC 0.01 50V Z
D409,410	0B06398A	SID 1SS176	R411	0B09701A	RK 10K 1/6W J	C141	0B40076A	CE 33 16V
D411	0B12693A	SID S5688B	R412	0B09677A	RK 1K 1/6W J	C142	0B47133A	CC 0.01 50V Z
D412,413	0B06398A	SID 1SS176	R413	0B09718A	RK 51K 1/6W J	C143	0B40074A	CE 10 16V
D416,417	0B06398A	SID 1SS176	R414	0B09701A	RK 10K 1/6W J	C144	0B41526A	CML 0.18 50V J
D418	0B06398A	SID 1SS176	R415	0B09749A	RK 1M 1/6W J	C145	0B40078A	CE 100 16V
D419	0B12693A	SID S5688B	R416	0B09693A	RK 4.7K 1/6W J	C146	0B47117A	CC 0.1 50V Z
D420,421	0B06398A	SID 1SS176	R417	0B09717A	RK 47K 1/6W J	C147	0B40115A	CE 4.7 50V
D422	0B06398A	SID 1SS176	R418	0B09685A	RK 2.2K 1/6W J	C148	0B41525A	CML 0.015 50V J
L101,102	0B51369A	Inductor 10uH	R419	0B09717A	RK 47K 1/6W J	C149	0B47117A	CC 0.1 50V Z
L401	0B51132A	Inductor 330uH	R420	0B09701A	RK 10K 1/6W J	C150	0B40063A	CE 100 10V
		LAL03TA331K	R422	0B09717A	RK 47K 1/6W J	C155	0B41885A	CC 220P 50V J
			R424	0B09653A	RK 100 1/6W J	C401	0B40085A	CE 4700 16V
L801,802	0B51369A	Inductor 10uH	R501,502	0B09701A	RK 10K 1/6W J	C402	0B41298A	CML 0.1 50V J
X501	0B92033A	Crystal 4.0MHz	R503	0B09701A	RK 10K 1/6W J	C403	0B41300A	CML 0.15 50V J
R801	0B92039A	X'tal 1.69344MHz	R506	0B09713A	RK 33K 1/6W J	C404,405	0B40078A	CE 100 16V
VR101	0B32145A	Semi VR B10K	R514,515	0B09725A	RK 100K 1/6W J	C406	0B41823A	CML 0.01 50V J
VR102,103	0B32146A	Semi VR 20K	R516,517	0B09725A	RK 100K 1/6W J	C407	0B40074A	CE 10 16V
VR104	0B32146A	Semi VR 20K	R519,520	0B09725A	RK 100K 1/6W J	C408	0B40082A	CE 1000 16V
VR105	0B30170A	Semi VR 1K	R521	0B09725A	RK 100K 1/6W J	C409	0B40052A	CE 470 6.3V
RA501	0B20656A	R Array 47Kx9	R533	0B09725A	RK 100K 1/6W J	C411	0B42054A	Gold Cap 0.22F 5.5V
R101	0B09629A	RK 10 1/6W J	R534,535	0B09717A	RK 47K 1/6W J	C501	0B47117A	CC 0.1 50V Z
R102	0B09677A	RK 1K 1/6W J	R536	0B09717A	RK 47K 1/6W J	C504,505	0B47133A	CC 0.01 50V Z
R103	0B09701A	RK 10K 1/6W J	R539	0B09725A	RK 100K 1/6W J	C506	0B47133A	CC 0.01 50V Z
R104	0B09699A	RK 8.2K 1/6W J	R540,541	0B09701A	RK 10K 1/6W J	C801,802	0B41975A	CC 10P 50 C
R105	0B09685A	RK 2.2K 1/6W J	R801,802	0B09661A	RK 220 1/6W J	C803,804	0B47117A	CC 0.1 50V Z
R106	0B09699A	RK 8.2K 1/6W J	R803,804	0B09661A	RK 220 1/6W J	C805	0B41298A	CML 0.1 50V J
R107	0B09725A	RK 100K 1/6W J	R805L,R	0B25671A	RM 5.6K 1/4W F	C806,807	0B40115A	CE 4.7 50V
R108	0B09677A	RK 1K 1/6W J	R806L,R	0B25671A	RM 5.6K 1/4W F	C808L,R	0B41201A	CPP 100P 100V J
R109	0B09709A	RK 22K 1/6W J	R807L,R	0B25308A	RM 15K 1/4W F	C809L,R	0B41298A	CML 0.1 50V J
R110,111	0B09701A	RK 10K 1/6W J	R808L,R	0B09697A	RK 6.8K 1/6W J	C810L,R	0B41201A	CPP 100P 100V J
R112	0B09731A	RK 180K 1/6W J	R809L,R	0B09698A	RK 7.5K 1/6W J	C811L,R	0B41215A	CPP 390P 100V J
R113	0B09735A	RK 270K 1/6W J	R810L,R	0B09697A	RK 6.8K 1/6W J	C812L,R	0B41298A	CML 0.1 50V J
R114	0B09742A	RK 510K 1/6W J	R811L,R	0B09671A	RK 560 1/6W J	C813L,R	0B40077A	CE 47 16V
R115	0B09719A	RK 56K 1/6W J	R812L,R	0B09653A	RK 100 1/6W J	CJ101	0B80638B	Ribbon Cable 10P
R116	0B09725A	RK 100K 1/6W J	R813L,R	0B09725A	RK 100K 1/6W J	CJ102	0B80639B	Ribbon Cable 2P
R117	0B09713A	RK 33K 1/6W J	R814L,R	0B09691A	RK 3.9K 1/6W J	CN103	0B80642A	Connector Ass'y CN103
R118	0B25291A	RM 10K 1/4W F	R815L,R	0B25308A	RM 15K 1/4W F	CN106	0B80643A	Connector Ass'y CN106
R119	0B25666A	RM 3.6K 1/4W F	C101	0B40063A	CE 100 10V	CN107	0B80644A	Connector Ass'y CN107
R120	0B09734A	RK 240K 1/6W J	C102	0B41944A	CC 1000P 50 K	CN401	0B80634B	Connector Ass'y CN401
R121	0B09701A	RK 10K 1/6W J	C103	0B41521A	CML 3300P 50V J	CN601	0B80631B	Connector Ass'y CN601
R122	0B25291A	RM 10K 1/4W F	C104	0B41708A	CC 22P 50V J	CN602	0B80632A	Connector Ass'y CN602
R123	0B09721A	RK 68K 1/6W J	C105	0B41294A	CML 0.047 50V J	CP101	0B81465A	8P T-Post
R124	0B09701A	RK 10K 1/6W J						

MB-3s Electrical Parts list (2/2)

Schematic

Ref. No.	Part No.	Description
CP102	0B81462A	5P T-Post
CP103	0B81463A	6P T-Post
CP106	0B84087A	12P T-Post
CP107	0B81461A	4P T-Post
PJ801	0B84226A	Pin Jack 2P
TP101	0B08182A	6P T-Post
TP102	0B02244A	7P T-Post
TP103	0B02233A	2P T-Post
GND1	0B84388A	Screw Terminal
GND2	0J05898C	Earth Plate
	0B80657A	Lead Wire (1)
	0B80659A	Lead Wire (1)
	0B90019A	SK Binder SKB80 (6)
	0B90464A	Heat Sink (1)

8.5. Display P.C.B. Ass'y

Schematic Ref. No.	Part No.	Description
	BA09069A	Display P.C.B. Ass'y
	0B61130A	Display P.C.B.
U601	0B11891A	IC LC7582A
U602	0B10555A	Remote Control Sensor GP1U581Y
LP601	0B90640A	Lamp 200mA 5V
R601	0B09717A	RK 47K 1/6W J
R602,603	0B09725A	RK 100K 1/6W J
R604,605	0B09725A	RK 100K 1/6W J
C601	0B47117A	CC 0.1 50V Z
C602	0B05571A	CML 680P 50V J
CN603	0B80633B	Connector Ass'y
LCD1	0B90641A	LCD GTD-12743AA

8.2. Transformer P.C.B. Ass'y

Schematic

Ref. No.	Part No.	Description
		Transformer P.C.B. Ass'y
	0B61140A	Transformer P.C.B.
LF1,2	0B51397A	Inductor 15uH VW1
WP101	0B84275A	Wrapping Terminal 2P
	0B90366A	Fuse Clip (FP-217) (2)

8.3. Power Switch P.C.B. Ass'y

Schematic

Ref. No.	Part No.	Description
	BA09071A	Power Switch P.C.B. Ass'y
	0B61132A	Power Switch P.C.B.
S401	0B70226A	Push Switch

8.4. Key P.C.B. Ass'y

Schematic

Ref. No.	Part No.	Description
	BA09070A	Key P.C.B. Ass'y
	0B61131A	Key P.C.B.
R607,608	0B09717A	RK 47K 1/6W J
R609,610	0B09717A	RK 47K 1/6W J
S601,602	0B70227A	Tact Switch LCP-S
S603,604	0B70227A	Tact Switch LCP-S
S605,606	0B70227A	Tact Switch LCP-S
S607,608	0B70227A	Tact Switch LCP-S
S609,610	0B70227A	Tact Switch LCP-S
S611,612	0B70227A	Tact Switch LCP-S
S613	0B70227A	Tact Switch LCP-S

9. IC BLOCK DIAGRAMS

U501 μ PD75517-230 (Mechanism Controller)

Pin No.	Signal Name	I/O	Function
1	–	–	Connected to GND.
2	AVREF	–	Connected to +5V (MB-1s). Connected to GND (MB-2s/3s).
3 4	VDD	–	+5V
5	ST UP	O	Stocker motor drive signal. Stocker raises when "H".
6	ST DWN	O	Stocker motor drive signal. Stocker lowers when "H".
7	FRONT	O	Loading motor drive signal. Disc tray is ejected when "H".
8	REAR	O	Loading motor drive signal. Disc tray is loaded when "H".
9	DSP. INH	O	Display inhibit signal.
10	DSP. DT	O	Serial display data.
11	DSP. CK	O	Clock for display data at pin 10.
12	DSP. EN	O	Latch pulse for display data at pin 10.
13	EMP	O	De-emphasis control signal. H: De-emphasis ON.
14	MUTG	O	Mute control signal.
15	REM. ACK	O	Acknowledge of remote control signal. (MB-1s/2s)
16	NC	O	Not used.
17	K. DATA	I	Not used.
18	–	I	Connectd to GND.
19	K. CLK	I	Not used.
20	–	I	Connected to GND.
21 to 24	$\overline{T3-T0}$	O	Key matrix scanning signals.
25 to 28	$\overline{K3-K0}$	I	Key matrix input signals.
29	MOD. SEL	I	Mode select signal. Fixed at "L".
30	RAM CLR	I	RAM reset input. Can use at power ON.
31	STBY	I	Not used.
32	DSP. LCD	I	Fixed at "L".
33	VSS	–	GND
34	FGC	O	Focus gain control signal (MB-1s).
35	TGC2	O	Tracking gain control 2 signal (MB-1s).
36	TGC1	O	Tracking gain control 1 signal (MB-1s).
37	M. POFF	O	Not used.
38	LDON	O	Laser ON signal.
39	XLT	O	Latch pulse for data at pin 41.
40	CLK	O	Clock for data at pin 41.

Pin No.	Signal Name	I/O	Function
41	DATA	O	8-bit serial data to LSIs.
42	SENSE	I	Sense signal from LSIs.
43	FOK	I	Focus OK signal.
44	GFS	I	Frame sync lock signal.
45	CRCF	I	CRC (cyclic redundancy code) check result signal for subcode Q.
46	REM	I	Fixed at "H".
47	-	I	Connected to GND.
48	SCOR	I	Subcode input trigger signal.
49	SG. IN	I	Remote controller input signal.
50	SUBQ	I	Subcode Q data.
51	-	I	Connected to GND.
52	SQCK	O	Clock for inputting subcode Q data.
53	P. OFF	I	Power OFF signal.
54	VSS	-	GND
55	-	I	Connected to GND.
56	-	O	Not used.
57	IC	-	Connected to GND.
58 59	X1 X2	-	Connected to 4MHz crystal.
60	RESET	I	System reset signal.
61	-	I	Connected to GND.
62	D. DET	I	Disc presence detecting input.
63	D. CNT	I	Stocker position counting input.
64	CENTER	I	Disc tray center detecting input.
65	T. CLOSE	I	Disc tray close detecting input.
66 67 68	POS3 POS2 POS1	I	Pickup position detecting inputs.
69	INNER	I	Inner switch signal. Become "L" when the laser pickup reaches the innermost position.
70	H. POS	I	Stocker home position detecting input.
71	STORE	I	Disc tray stock position detecting input.
72	EJECT	I	Disc tray ejection detecting input.
73	-	-	Connected to GND.
74 to 78	-	I	Connected to GND.
79	F. IN	I	Analog-to-digital converted focus input. (MB-1s)
80	T. IN	I	Analog-to-digital converted tracking input. (MB-1s)

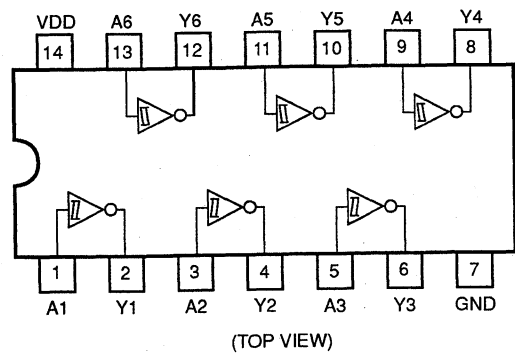

Fig. 9.1 Inverter TC4584BP

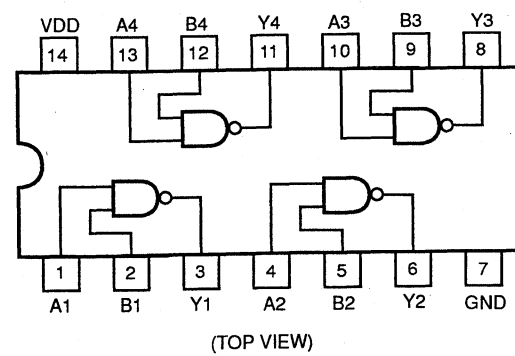
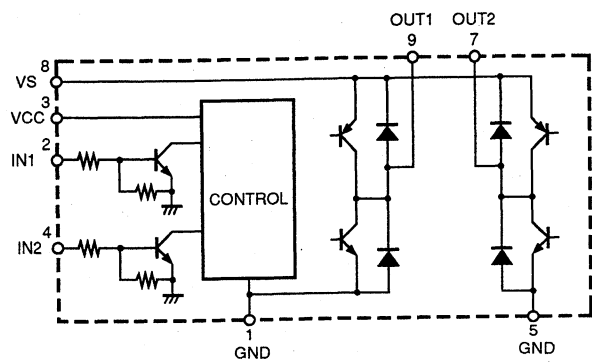

Fig. 9.2 NAND Gate TC74HC00AP



MODE	IN1	IN2	OUT1	OUT2
FWD	H	L	H	L
REV	L	H	L	H
BRAKE	H	H	L	L
STANDBY	L	L	OFF	OFF

Fig. 9.3 Motor Driver LB1638M

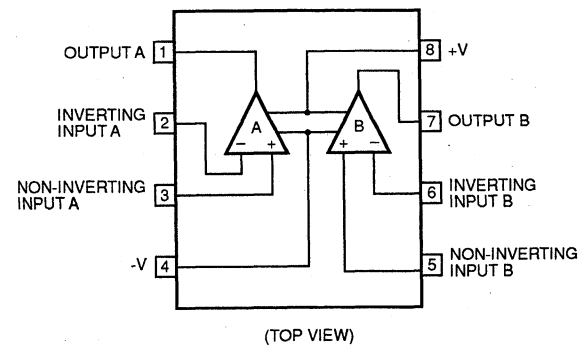

Fig. 9.4 Operational Amp. 4558D, 5532AN

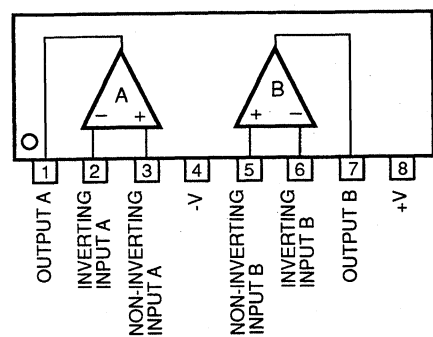

Fig. 9.5 Operational Amp. 4556L

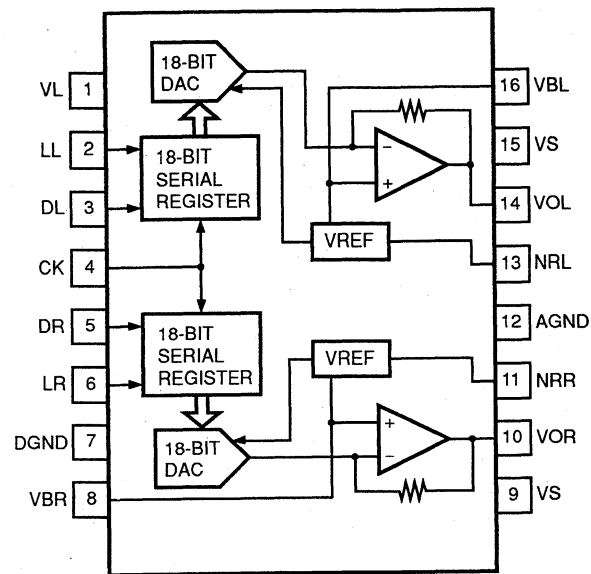

Fig. 9.6 Digital-to-Analog Converter AD1868R-J (MB-2s/3s)

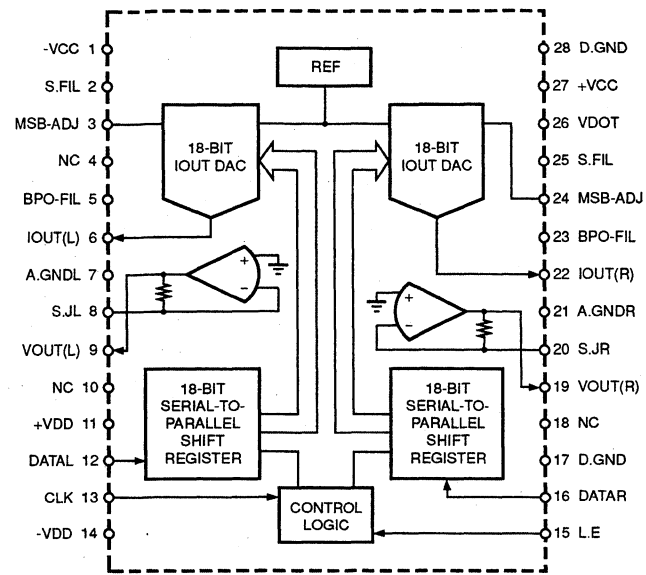

Fig. 9.7 Digital-to-Analog Converter PCM1700P (MB-1s)

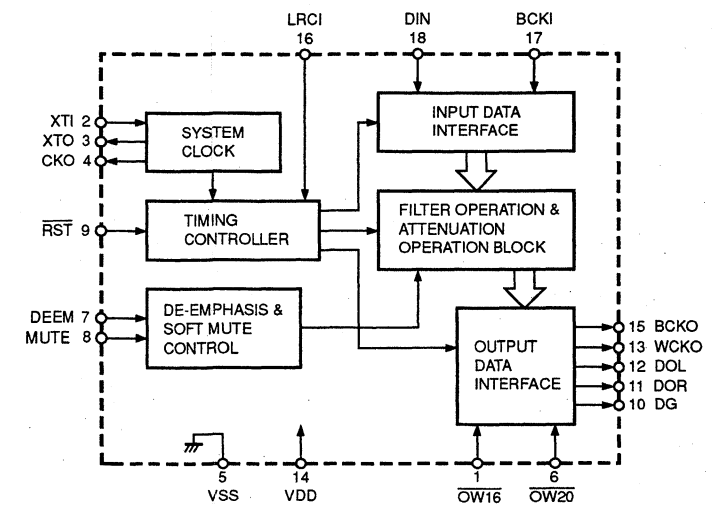

Fig. 9.8 8-Times Oversampling Digital Filter SM5841CP

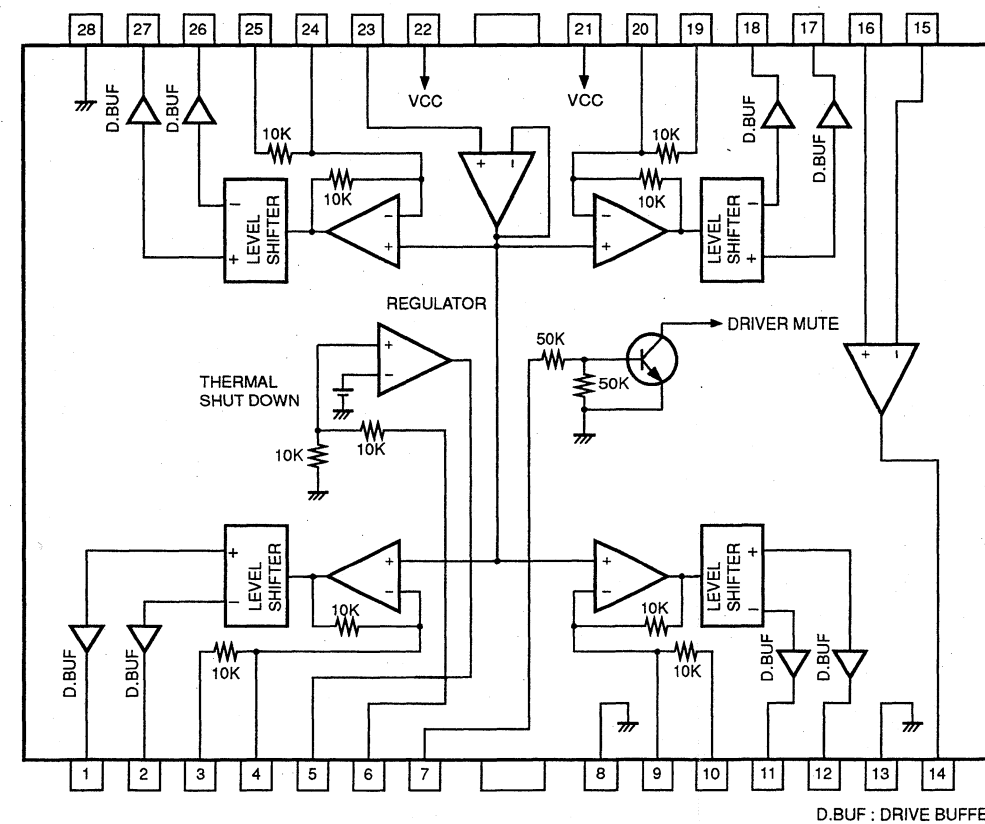

Fig. 9.9 Dirver BA6296FP

10. BLOCK DIAGRAMS

10.1. For MB-1s

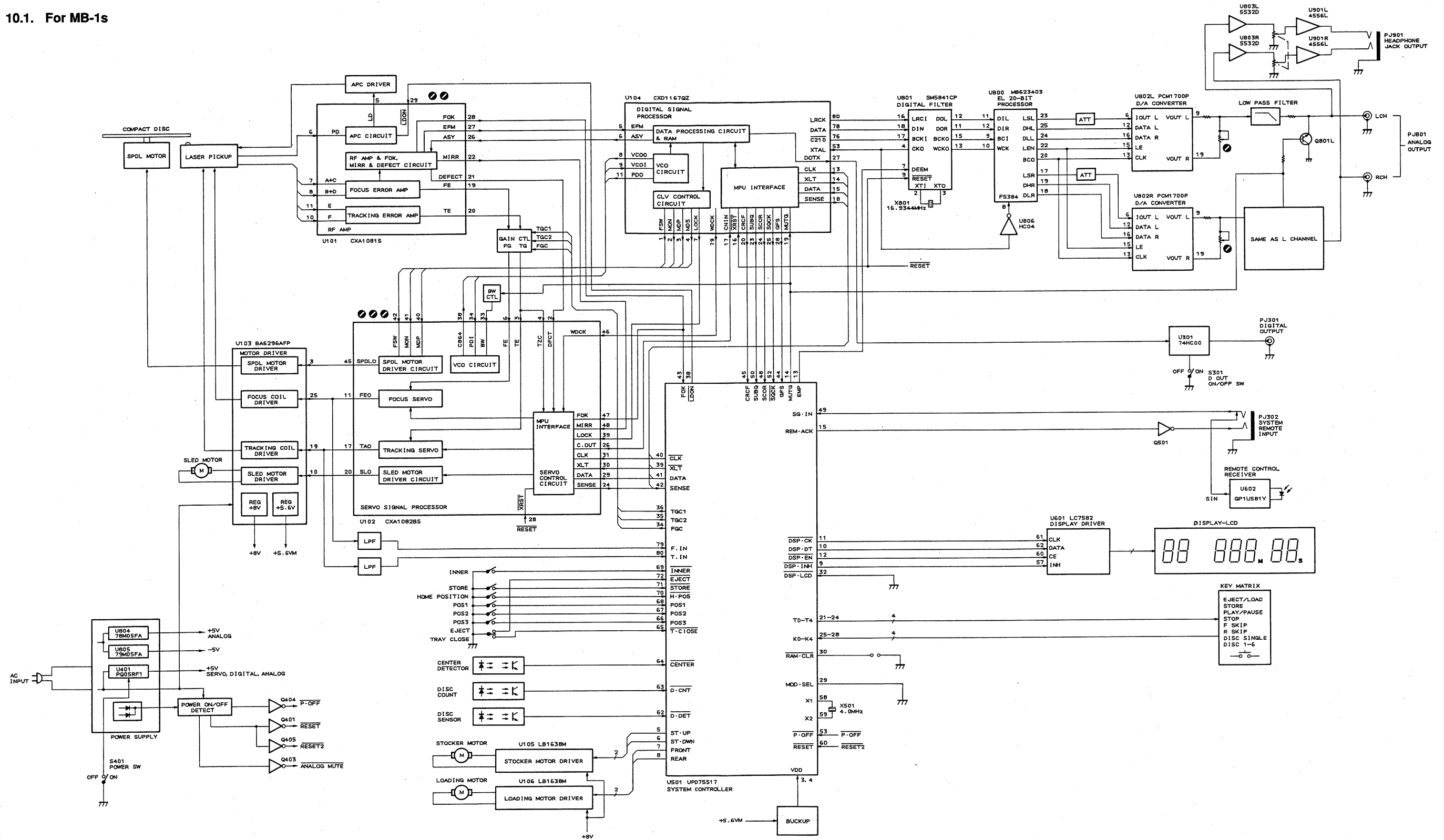

Fig. 10.1 (MB-1s)

10.2. For MB-2s and -3s

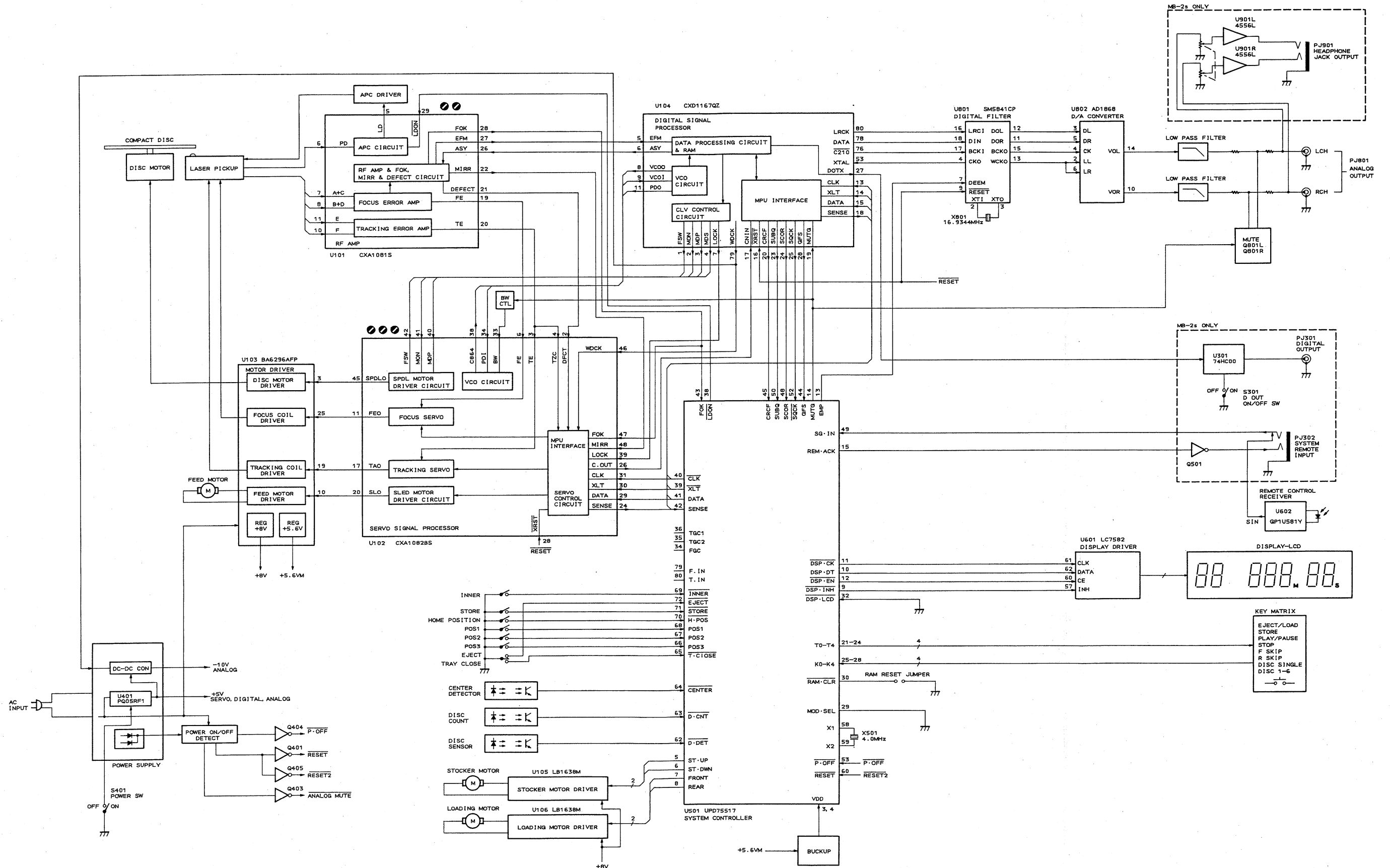
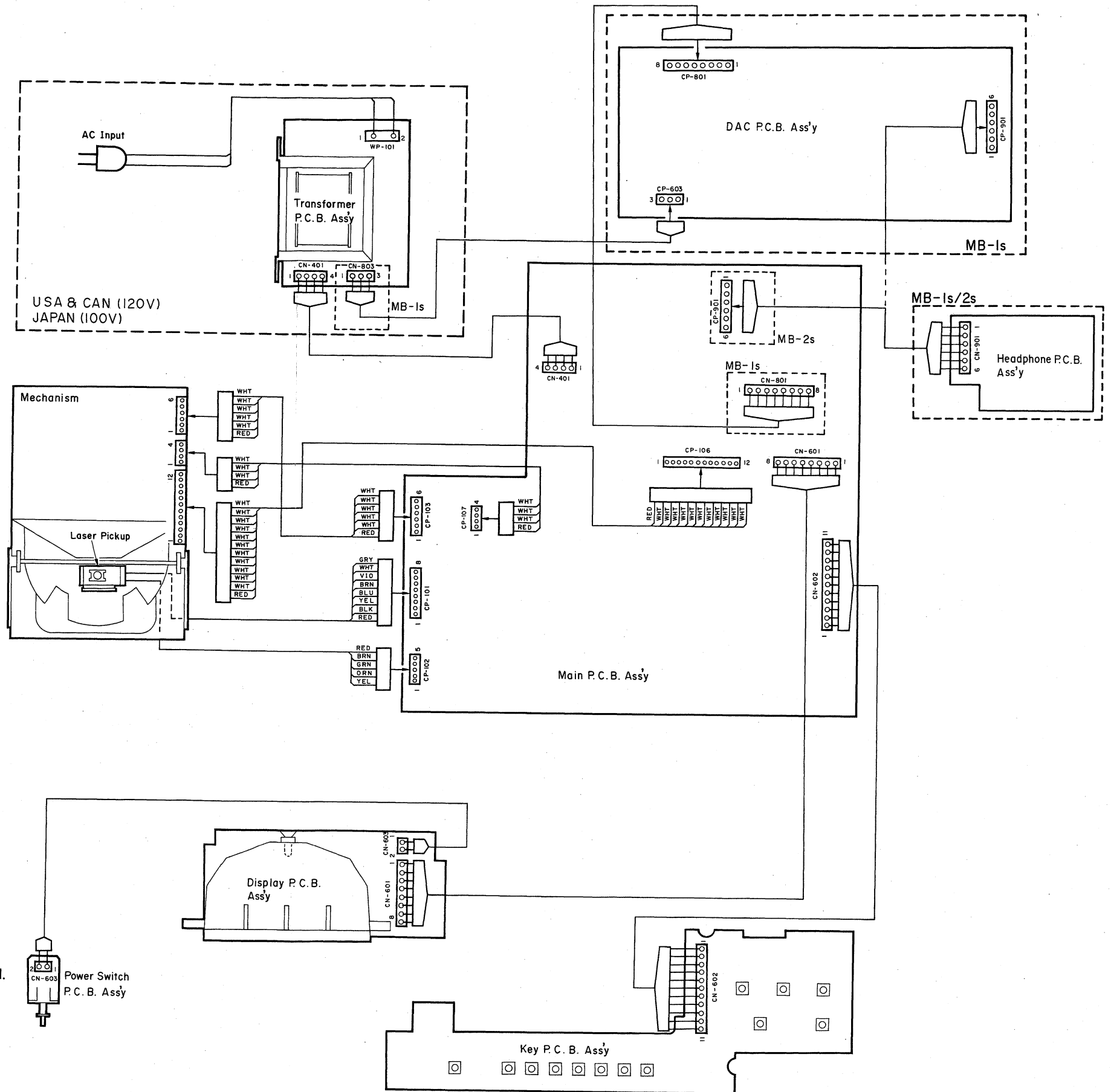
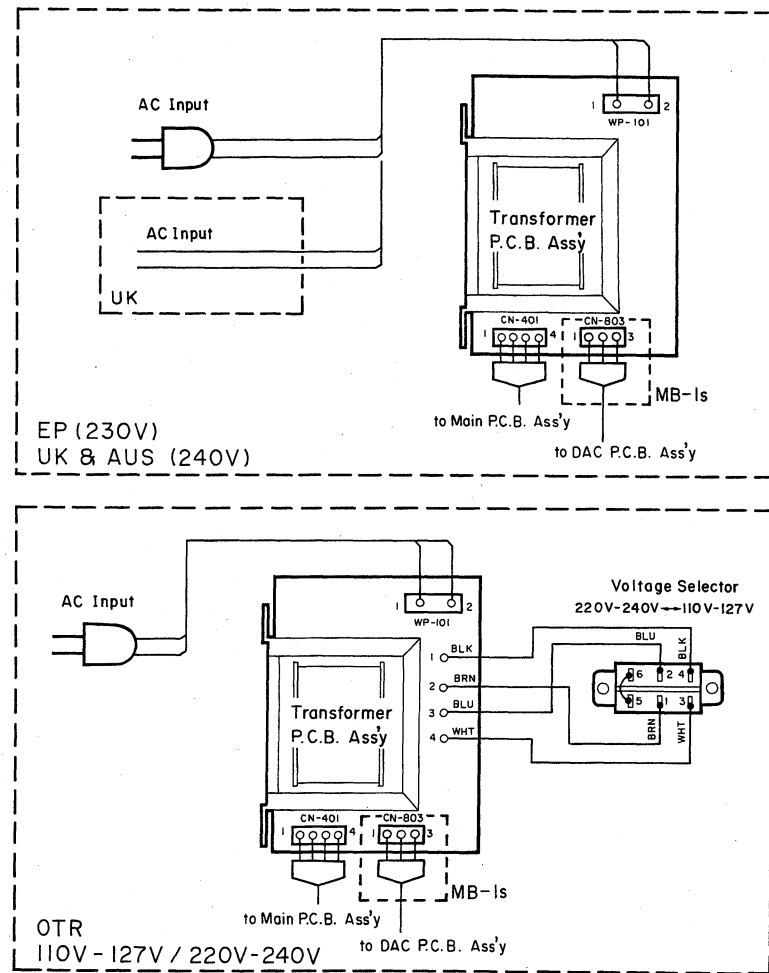

Fig. 10.2 (MB-2s and -3s)

11. WIRING DIAGRAMS



NOTES:

- Table of wire colors

BRN — Brown	BLU — Blue
RED — Red	VIO — Violet
ORN — Orange	GRY — Gray
YEL — Yellow	WHT — White
GRN — Green	BLK — Black
- Component side view of the P.C.B. is illustrated unless otherwise specified.

Fig. 11.1

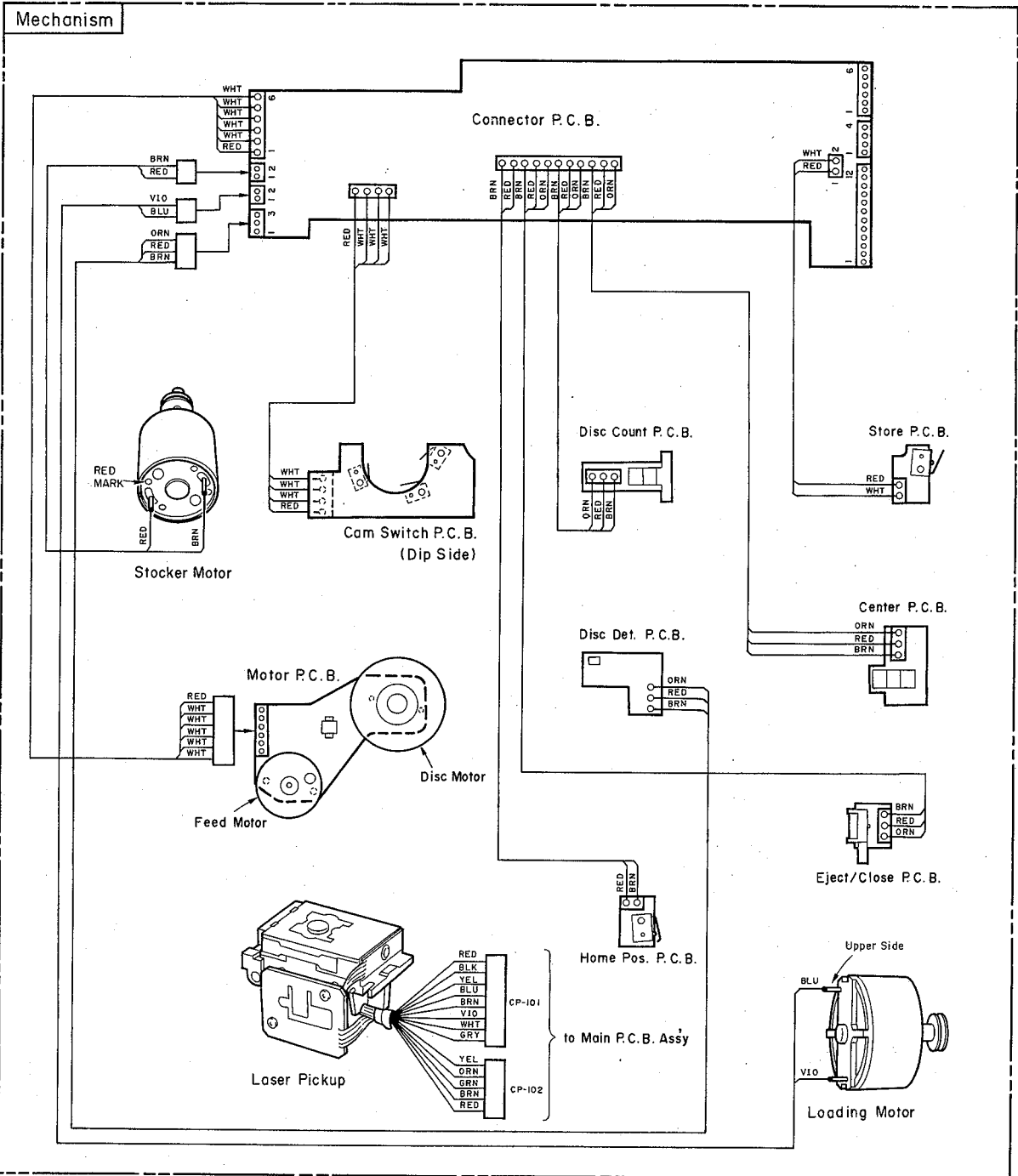

Fig. 11.2

12. SCHEMATIC DIAGRAM (DAC CIRCUIT [MB-1s])

NOTE: DAC circuit of MB-1s is shown below. For other circuits, see attached schematic diagrams.

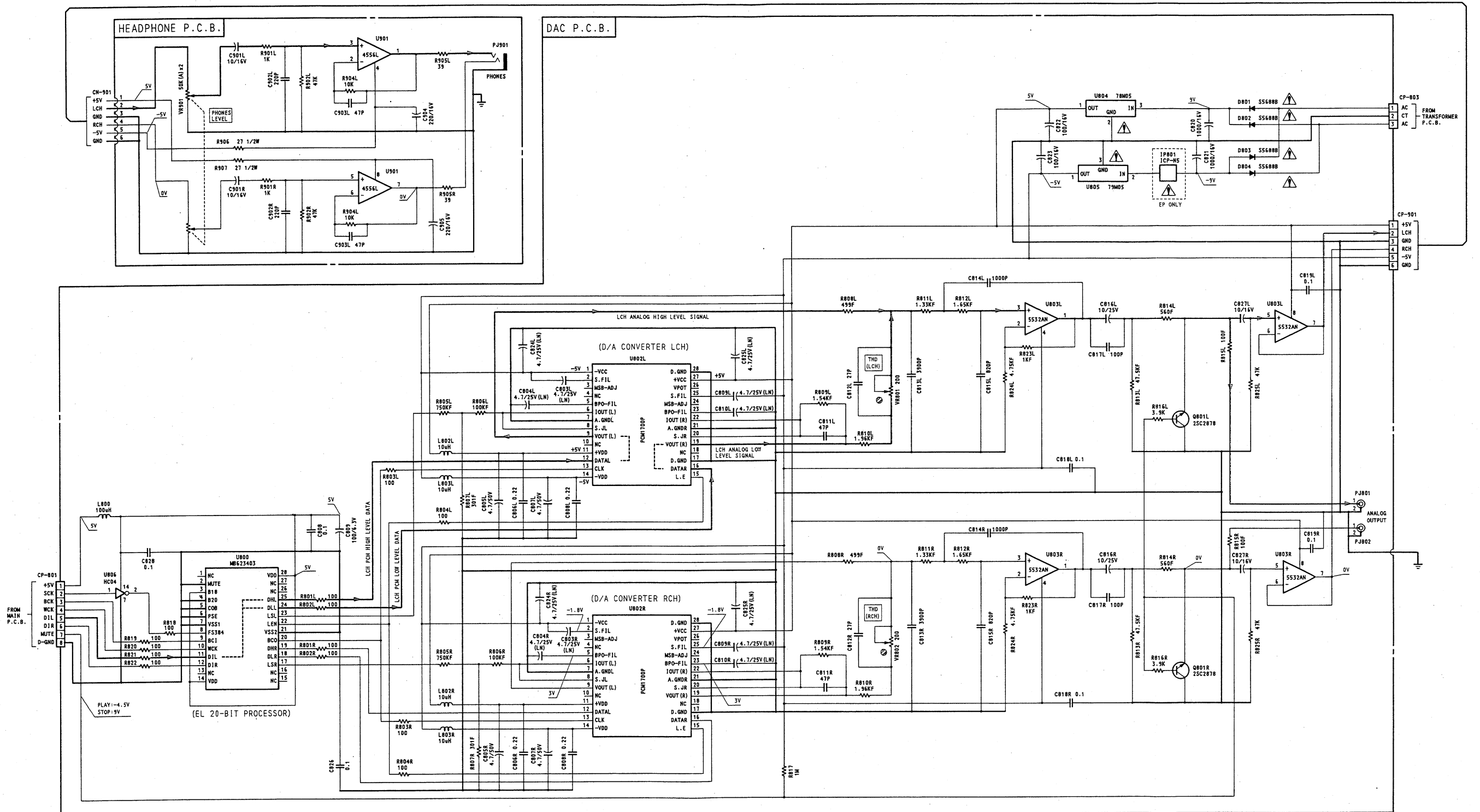
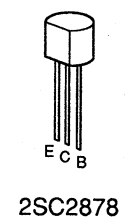
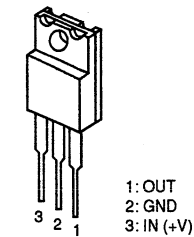

Fig. 12 DAC Circuit [MB-1s]

NOTE: Description of electrolytic capacitor: 100/16V = 100μ 16V



2SC2878



NJM78M05FA

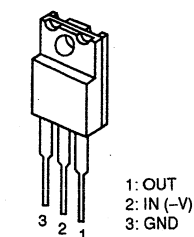

NJM79M05FA

SCHEMATIC DIAGRAM (MB-1s)

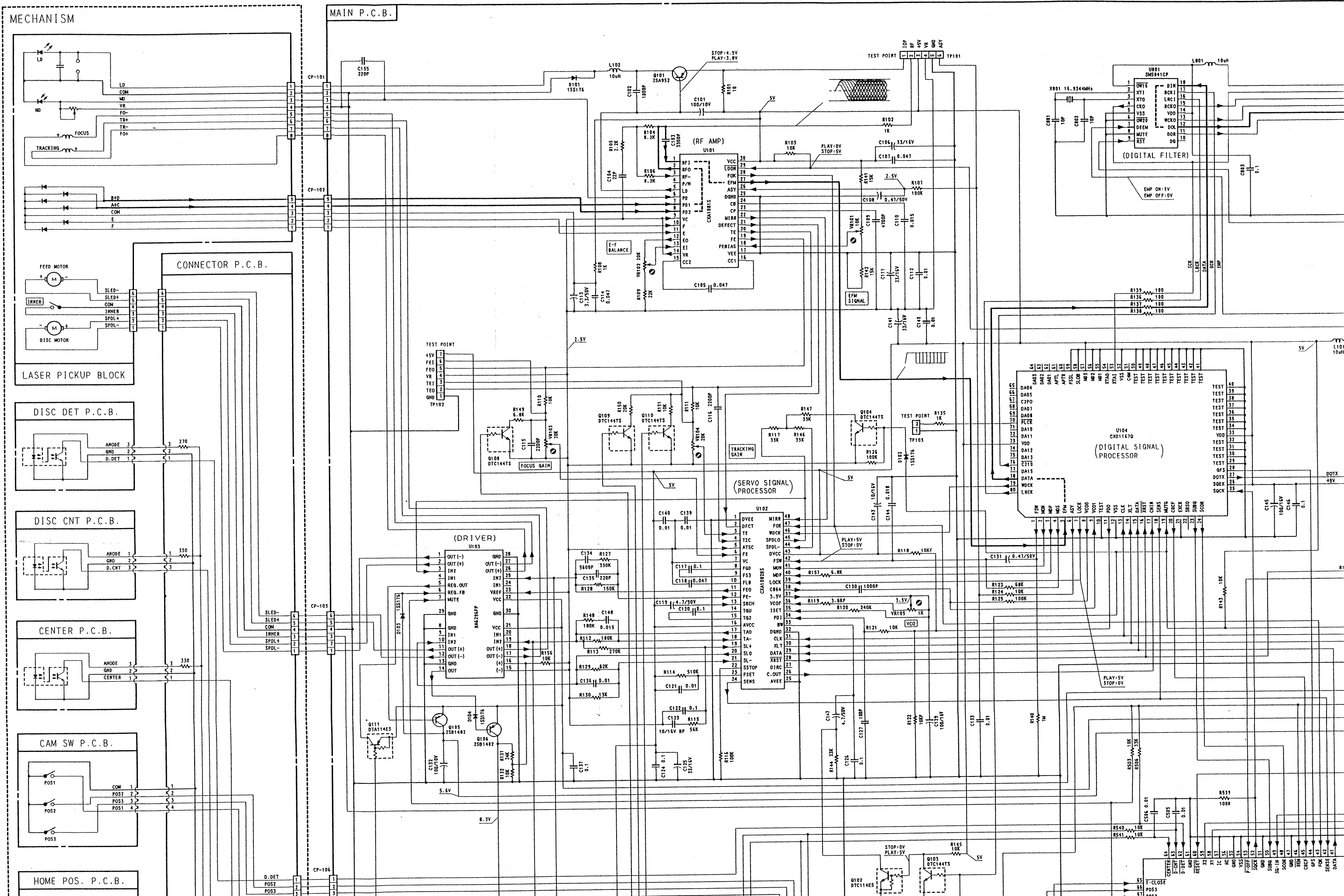

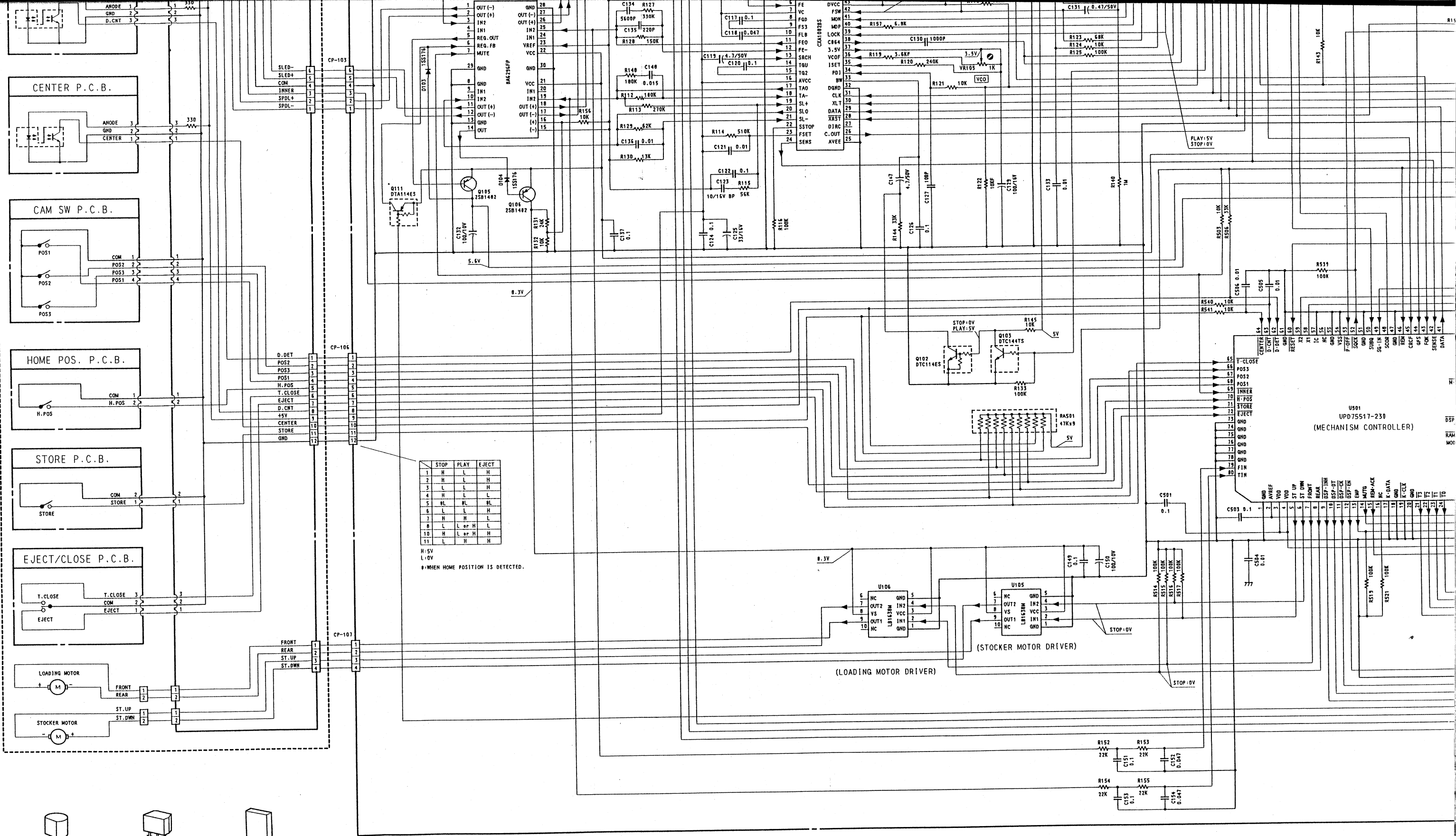

	STOP	PLAY	EJECT
1	H	L	H
2	H	L	H
3	L	L	H
4	H	L	L
5	HL	HL	HL
6	L	L	H
7	H	H	L
8	L	L or H	L
10	H	L or H	H
11	L	H	H

H: 5V
L: 0V
*WHEN HOME POSITION IS DETECTED.

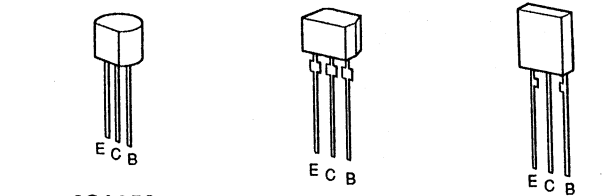

- 2SA952
- 2SA1015
- 2SC945
- 2SC2002
- 2SC2878
- DTA114ES
- DTC114ES
- DTC144TS
- 2SB1482

WARNING

Parts marked with the symbol  in the schematic diagram have critical characteristics. Use ONLY replacement parts recommended by the manufacturer. It is recommended that the unit be operated from a suitable DC supply or batteries during initial check-out procedures.

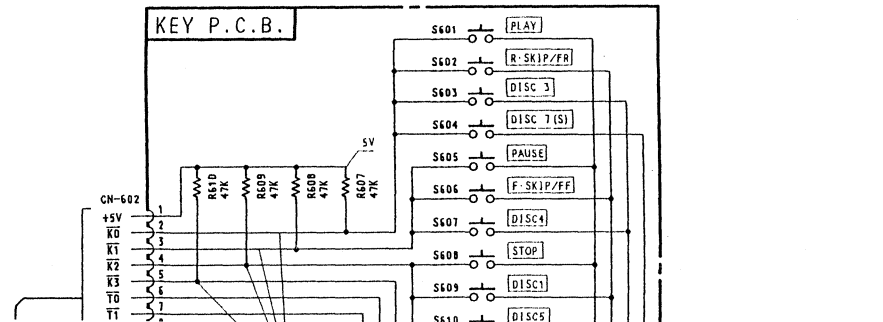
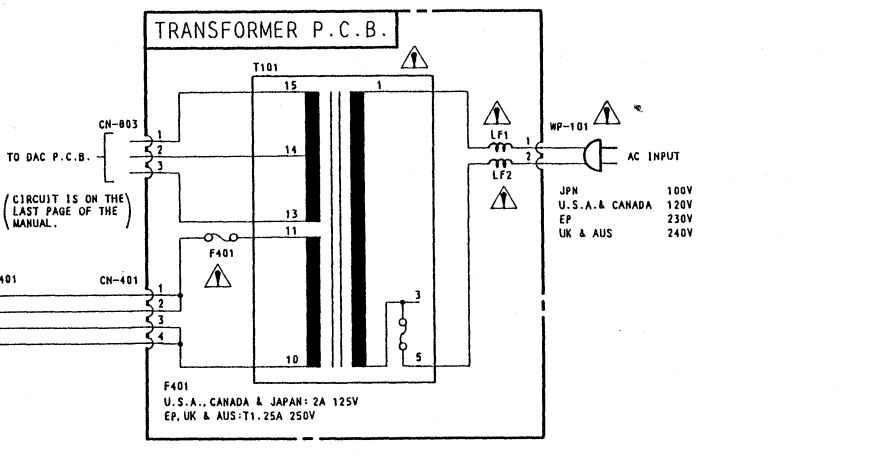
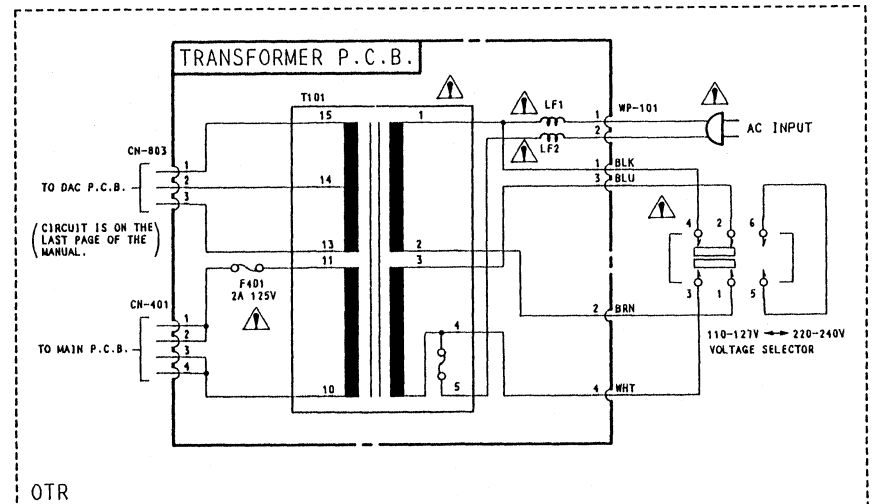
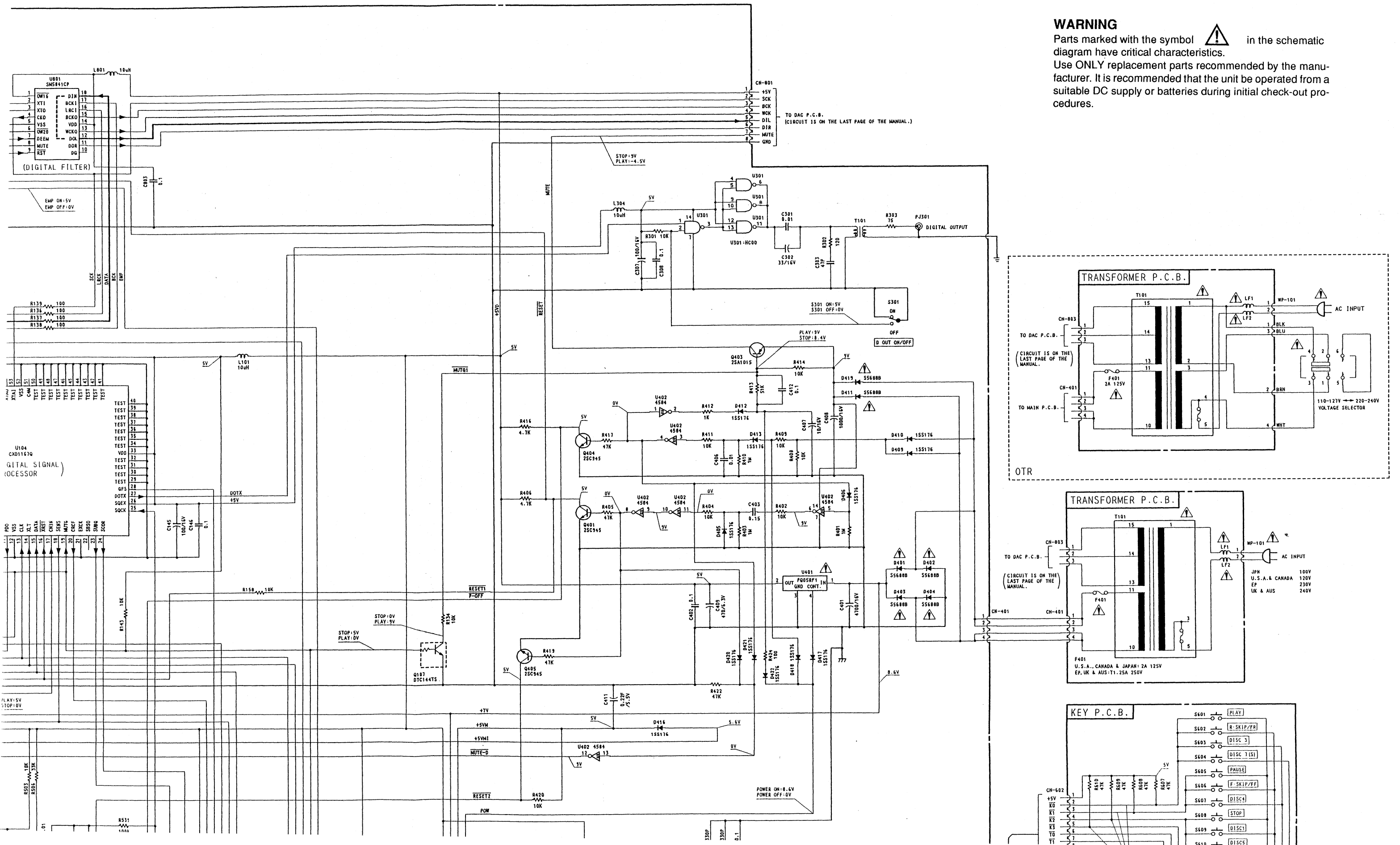

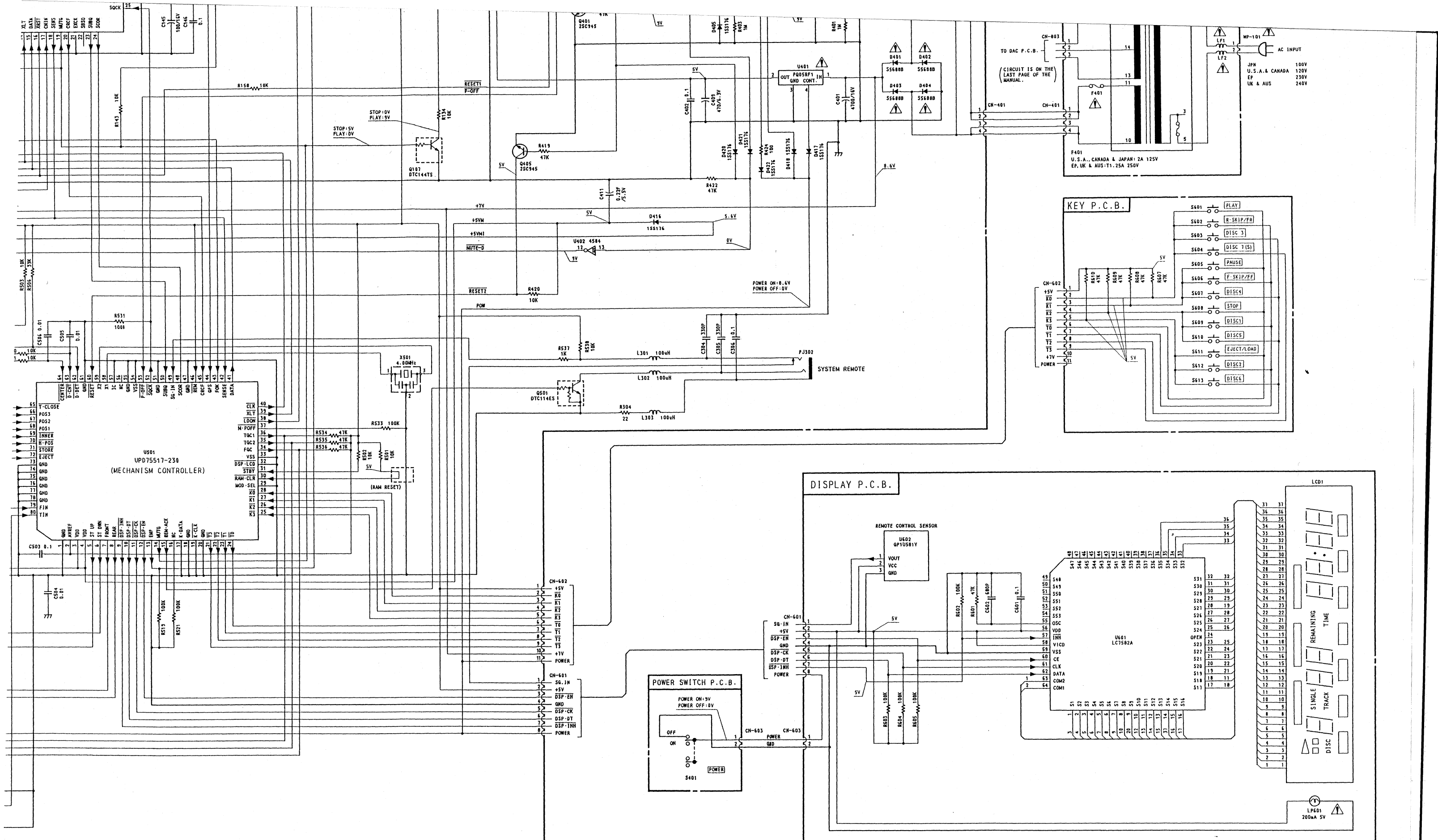

NOTES: 1. Diode is 1SS176, 1SS53, or 1S1555 unless otherwise specified.
 2. Description of electrolytic capacitor: 100/16V = 100µ 16V

SCHEMATIC DIAGRAM (MB-2s/3s)

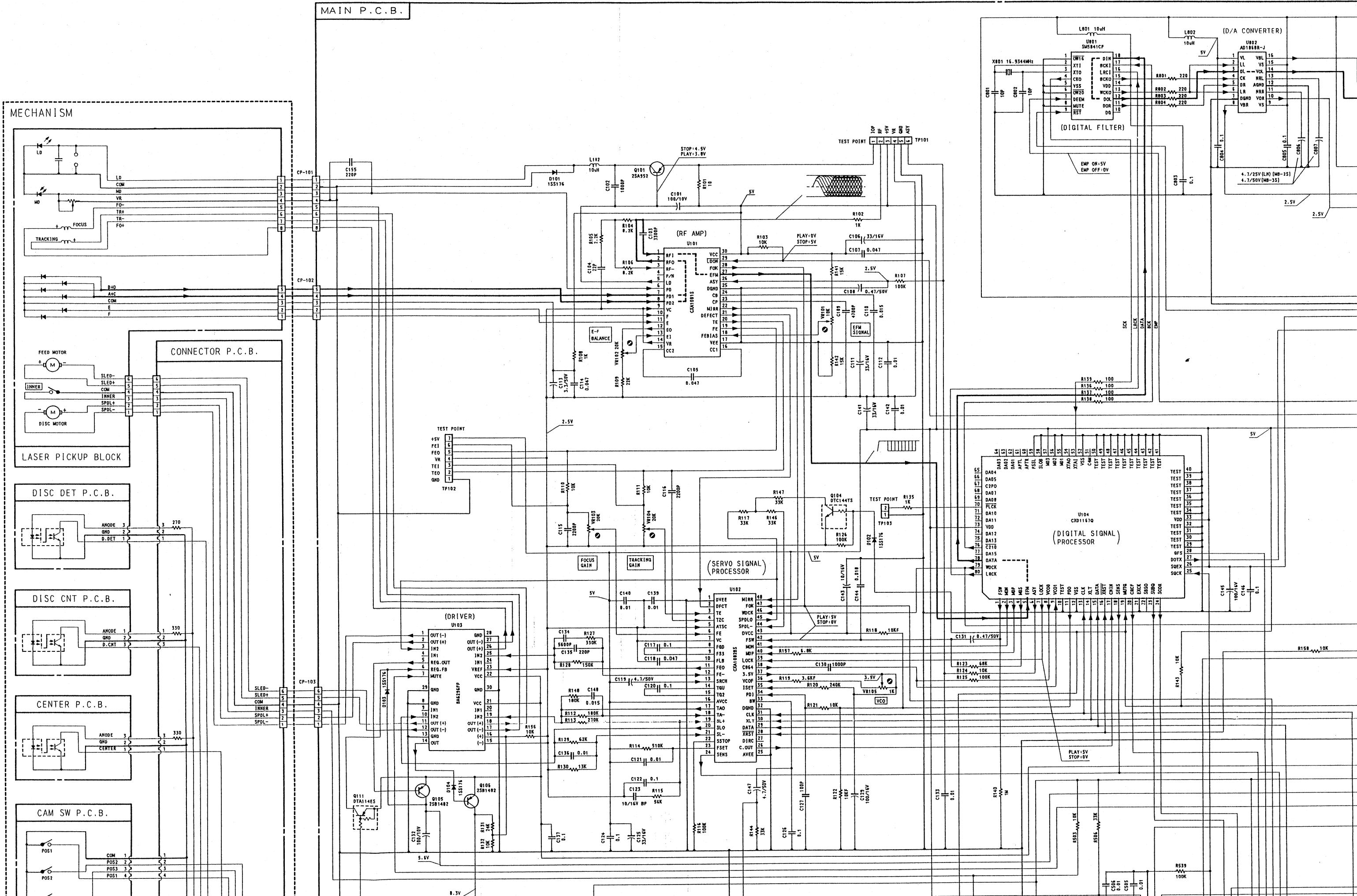

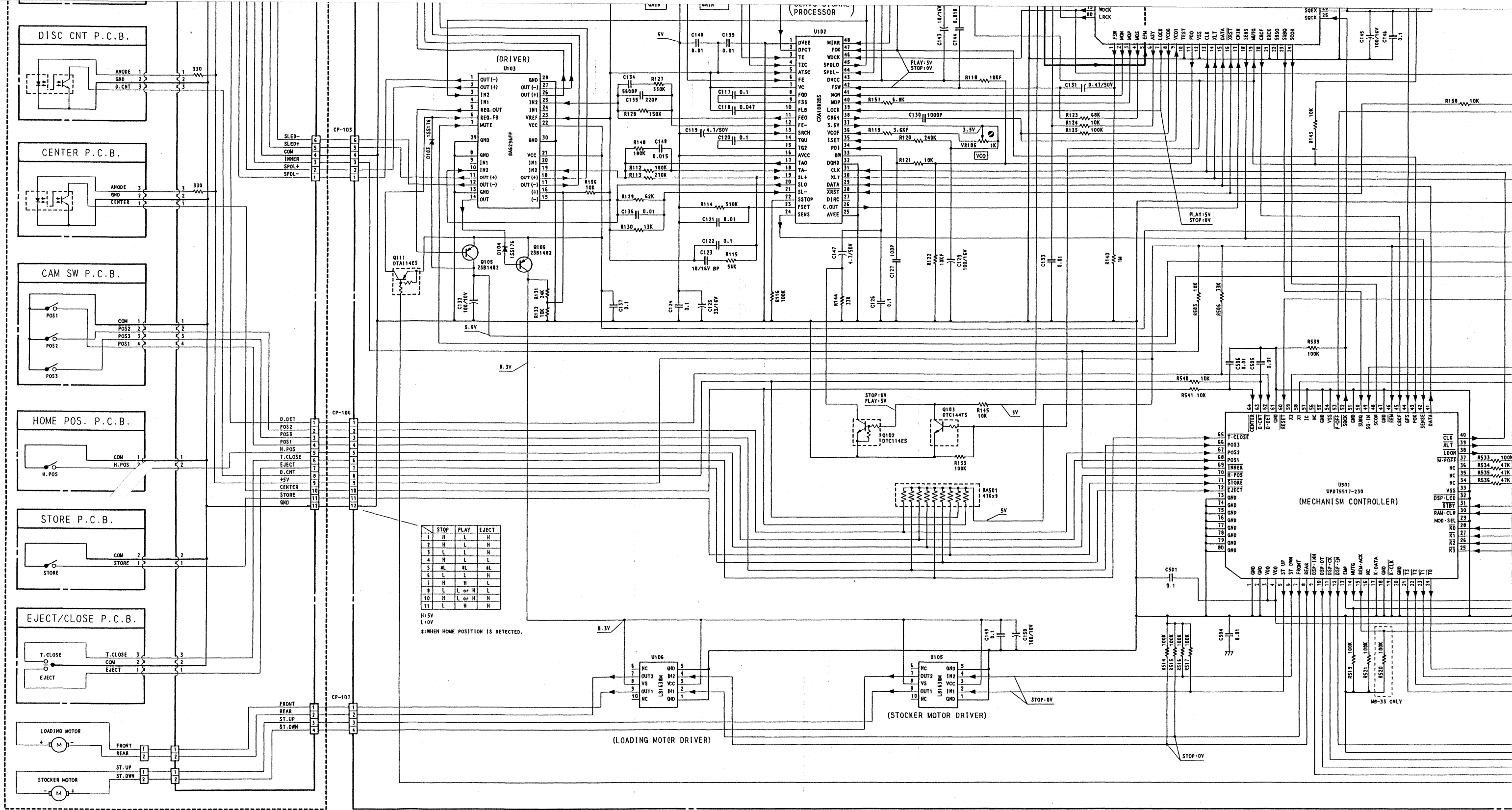

- 2SA952
- 2SA1015
- 2SC945
- 2SC2002
- 2SC2878

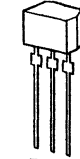

- DTA114ES
- DTC114ES
- DTC144TS



2SB1482

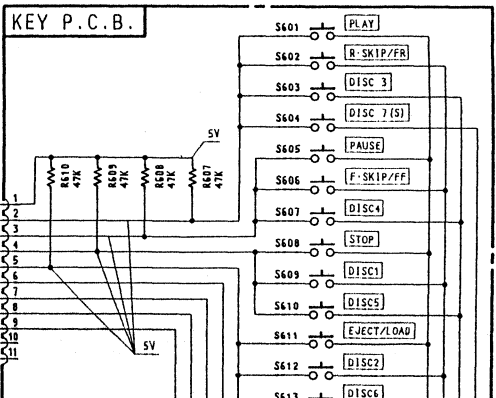
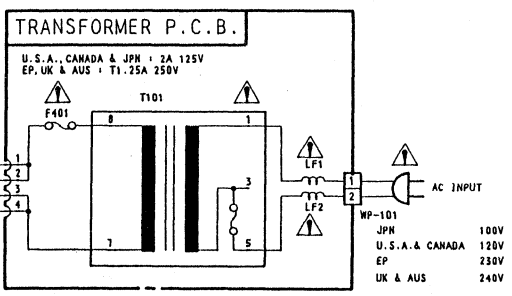
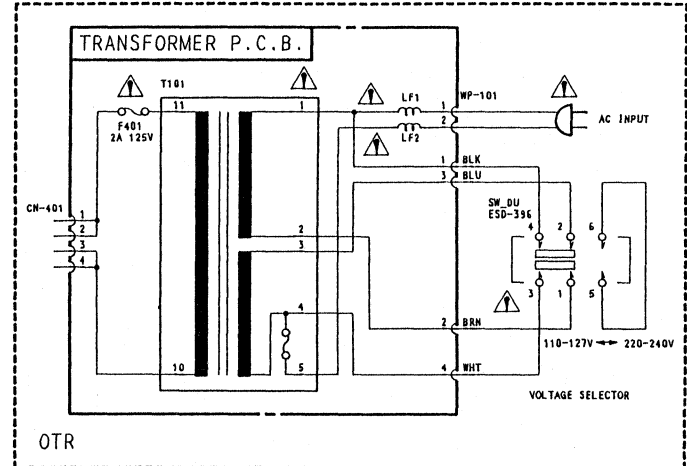
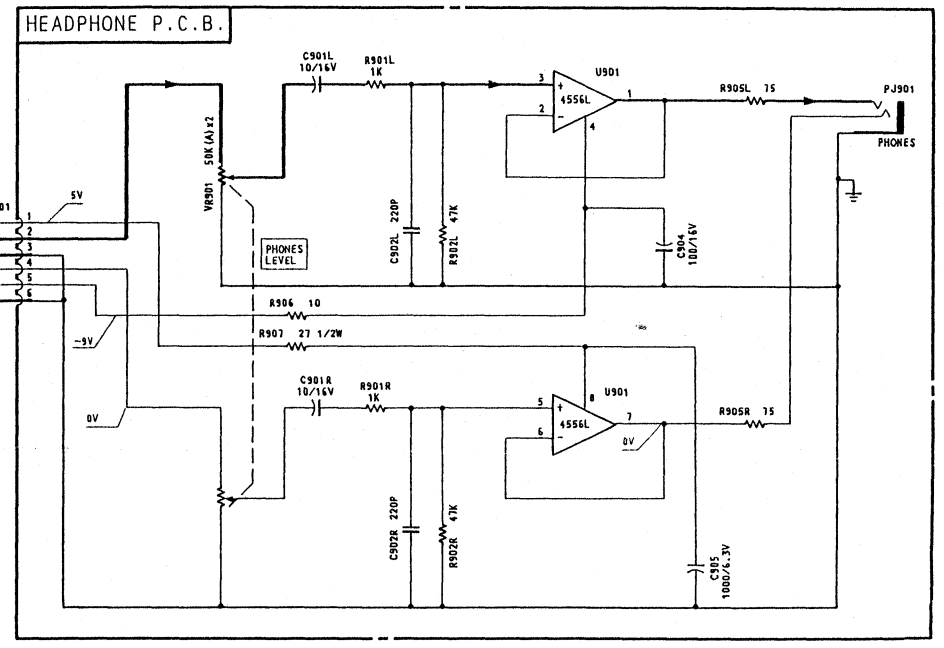
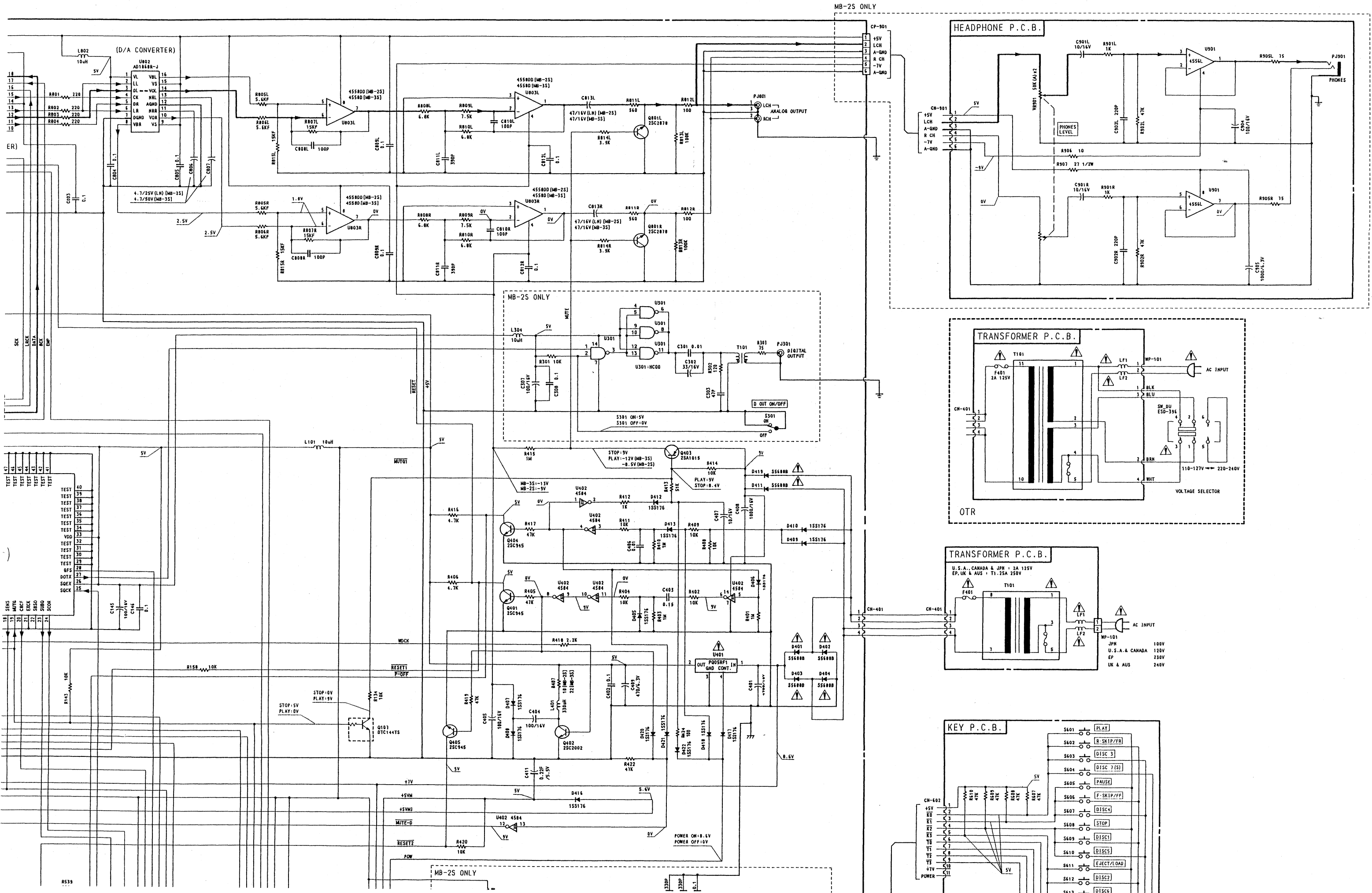

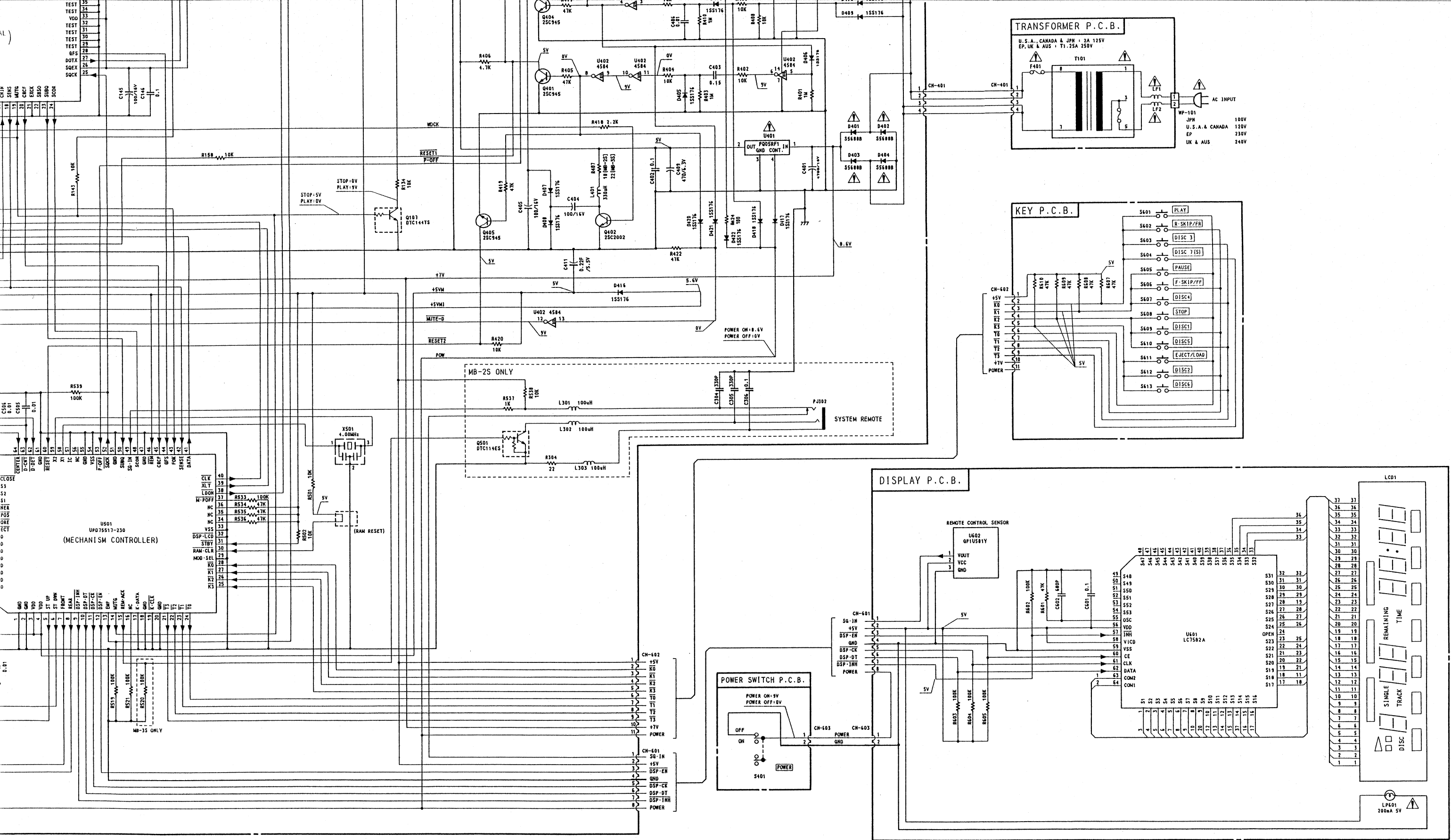

NOTES: 1. Diode is 1SS176, 1SS53, or 1S1555 unless otherwise specified.
 2. Description of electrolytic capacitor: 100/16V = 100µ 16V

WARNING  in the schematic diagram have critical characteristics. Use ONLY replacement parts recommended by the manufacturer. It is recommended that the unit be operated from a suitable DC supply or batteries during initial check-out procedures.

SPECIFICATIONS

•Main Unit

System	Compact disc digital audio
Signal Readout	Optical (semiconductor laser)
Error Correction	CIRC principle
Number of channels	2 channels, stereo
D/A Converter type	EL 20-bit dual D/A converters with 8-times oversampling digital filter [MB-1s] 18-bit dual D/A converters with 8-times oversampling digital filter [MB-2s/3s]
Sampling Frequency	44.1 kHz
Quantization	16-bit linear
Disc Rotational Velocity	Approx. 200 to 500 rpm (constant linear velocity)
Wow and Flutter	Below measurement limit
Frequency Response	20-20,000 Hz +0.5/-1.0 dB [MB-1s] 20-20,000 Hz +0.8/-1.2 dB [MB-2s/3s]
Total Harmonic Distortion (T.H.D. + Noise)	0.01% (1 kHz)
Signal to Noise Ratio	Better than 95 dB (IHF A-WTD) [MB-1s] Better than 93 dB (IHF A-WTD) [MB-2s/3s]
Dynamic Range	Better than 95 dB [MB-1s] Better than 88 dB [MB-2s/3s]
Channel Separation	Better than 90 dB
Output Level/Impedance	
Line (Fixed)	1.8 V/600 ohms (1 kHz, 0 dB)
Headphone (Variable)	75 mW/40 ohms (Phones Level Max.) [MB-1s] 50 mW/40 ohms (Phones Level Max.) [MB-2s]
Digital Output	75 ohms coaxial [MB-1s/2s]
Power Source	120, 230, 240 or 110-127/220-240 VAC, 50/60 Hz (according to country of sale)
Power Consumption	12W max. [MB-1s] , 10W max. [MB-2s/3s]
Dimensions*	430 (W) × 99 (H) × 270 (D) mm, 16-15/16(W) × 3-7/8 (H) × 10-5/8 (D) inches
Approximate Weight	5.5 kg, 12 lbs. 2 oz. [MB-1s] , 5.3 kg, 11 lbs. 11 oz. [MB-2s/3s]

•Remote Control Unit

Principle	Infrared pulse system
Power Supply	3 VDC (1.5 V × 2)
Dimensions*	57 (W) × 16 (H) × 152 (D) mm, 2-1/4 (W) × 5/8 (H) × 6 (D) inches [MB-1s/2s] 58 (W) × 17 (H) × 125 (D) mm, 2-5/16 (W) × 11/16 (H) × 4-15/16 (D) inches [MB-3s]
Approximate Weight	130 g, 5 oz. (including batteries) [MB-1s/2s] , 120 g, 4 oz. (including batteries) [MB-3s]

•Supplied Accessories	Shielded cable with RCA-type plug × 1 IEC R03 batteries (size AAA) × 2
-----------------------------	---

* Dimensions do not include protruding parts. Height is the panel height.

Nakamichi Corporation	1-153 Suzukicho, Kodaira, Tokyo 187 Phone: (0423) 42-1115
Nakamichi America Corporation	955 Francisco St., Torrance, CA 90502 Phone: (310) 538-8150
Nakamichi Canada	276 South West, Marine Drive, Vancouver, B.C. V5X 2R4 Phone: (604) 324-7535
Nakamichi Australia	Unit 12 620-632 Botany Road, Alexandria, N.S.W. 2015 Phone: (02) 667-0811
Nakamichi GmbH	Praunheimer Landstraße 32 D-60488 Frankfurt/Main Phone: (069) 7682021 (Office), 7682025 (Service)