

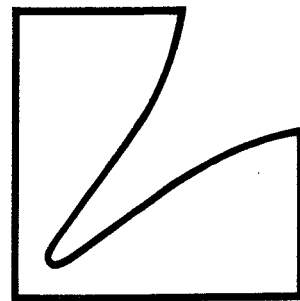

For more Hi-Fi manuals and set-up information
please visit www.hifiengine.com

SERVICE MANUAL



Compact Disc Digital Audio Player

D-103/D-404



D-103

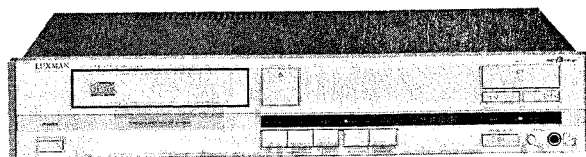

D-404

Contents (目次)

Specifications	2
Parts Locations	3
Disassembly Instructions	4 to 6
Block Diagram	7
Adjustment Locations	8
Adjustment Procedures	9 to 26
Wiring Diagram	27 to 28
Schematic Diagram	29 to 30
Parts List	31 to 35
Mechanism Exploded View	36
Mechanism Assembly Parts List	37
Exploded View (Cabinet)	38
Cabinet Assembly Parts List	39
Packing Method View	40
Packing Assembly Parts List	41

Specifications (仕様)

Type	Compact Disc player with optical pickup
Quantization	16 bit linear
Channels	2 (stereo)
Frequency response	5 Hz – 20 kHz $\begin{matrix} +1.0 \\ -1.5 \end{matrix}$ dB
Dynamic range	80 dB
Total harmonic distortion	0.01% (1 kHz)
Channel separation	80 dB
Wow and flutter	Unmeasurable
Output	2.0 \pm 0.5 volts
Pickup	Semiconductor laser type
Track location	By track
Power supply	AC 220V, 50 Hz (AK) AC 120V, 60 Hz (UZ, UC) AC 100V, 50/60 Hz (AJ)
Power consumption	13 watts (AJ) 14 watts (AK, UZ, UC)
Dimensions	439(W) x 75(H) x 300(D) mm (D-103) 453(W) x 75(H) x 300(D) mm (D-404)
Weight	5.1 kg
Accessories	Connection cables

Specifications are subject to change without notice.

Parts Locations (各部の名称)

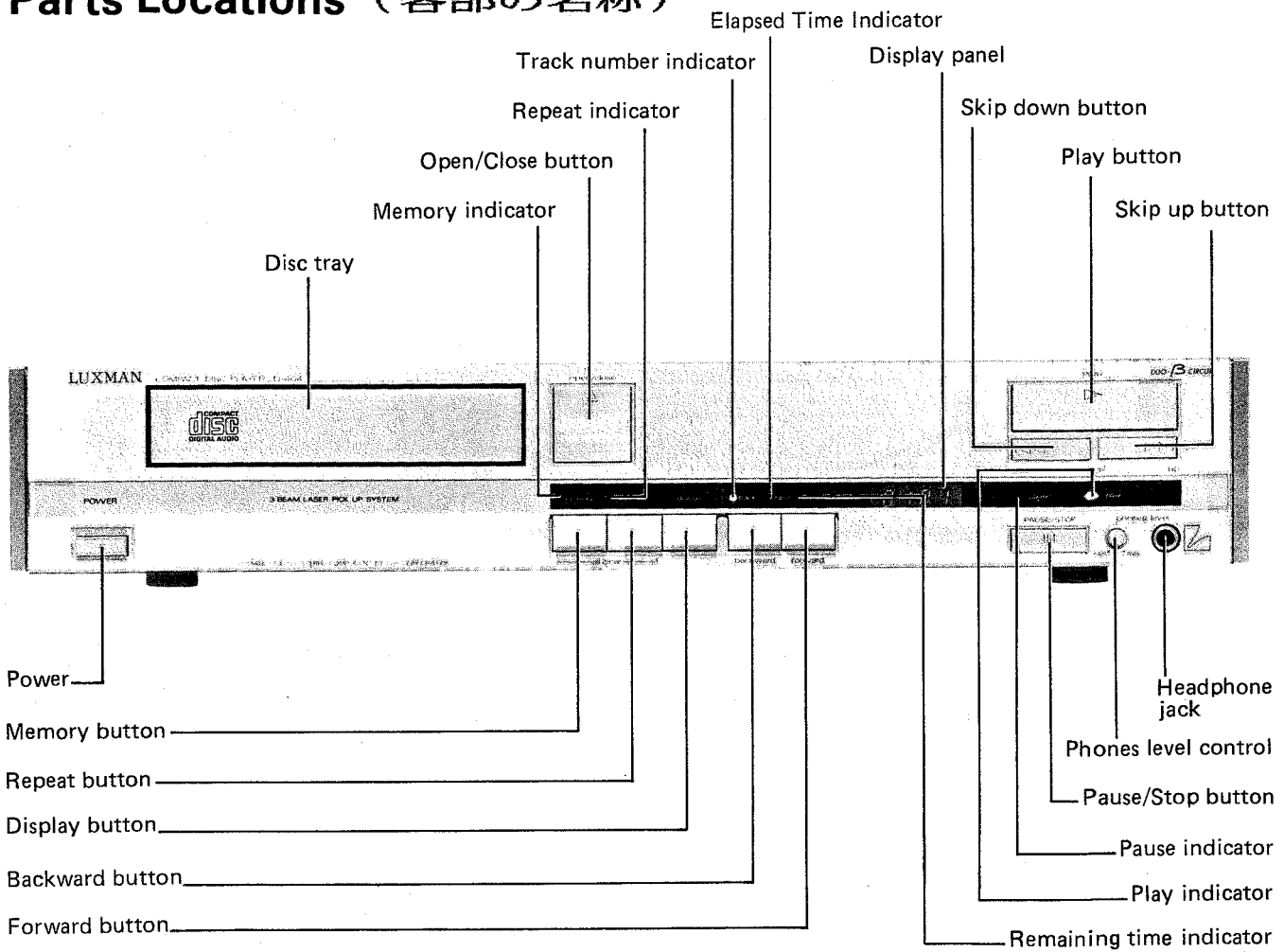

Figure 1
図 1

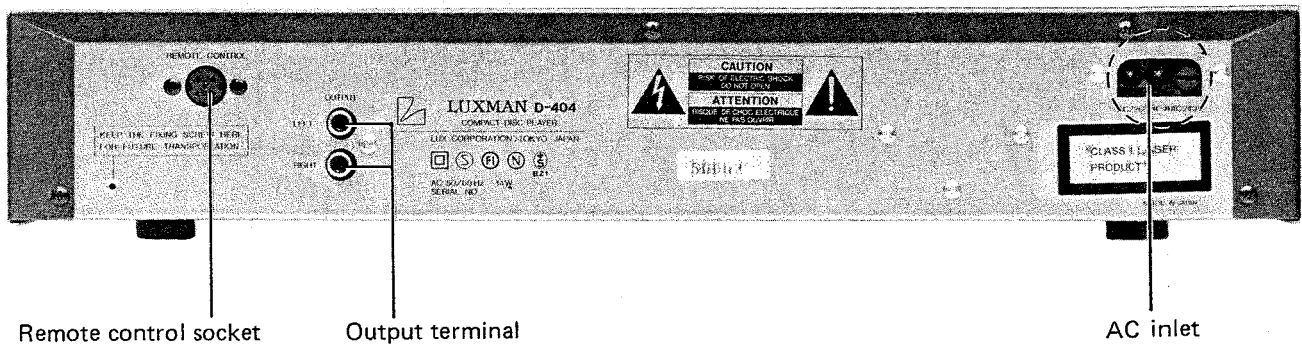

Figure 2
図 2

Disassembly Instructions (分解方法)

TOP COVER REMOVAL (MODEL SILVER)

1. Remove two screws (A) ($\phi 4 \times 8\text{mm}$ BLK), ($\phi 4 \times 6\text{mm}$ SILVER) and four screws (B) ($\phi 3 \times 8\text{mm}$), and the top cover will be removed from unit. (Figures 3, 4 and 5)

■トップカバーのはずし方

1. 側面のねじ2個 (A) とバックのねじ4個 (B) をはずせばトップカバーははずれます。(図3, 4, 5)

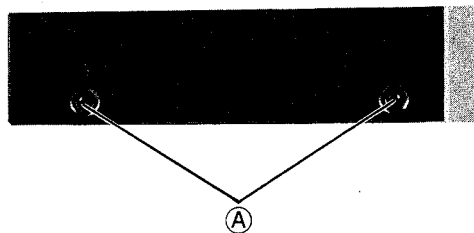

Figure 3
図3

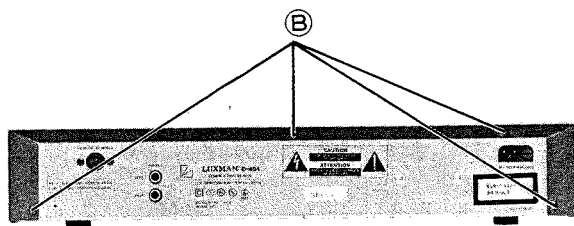

Figure 4
図4

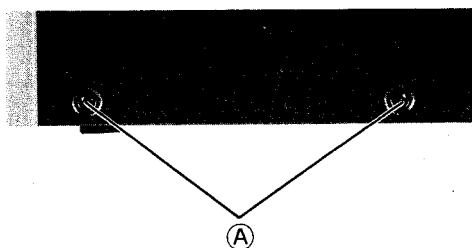

Figure 5
図5

TRAY PANEL OPENING

1. When opening the tray panel manually, rotate the gear counterclockwise up to the point where the disc tray slightly comes out. Then pull out the disc tray by your hand. (Figure 6)

■トレイパネルオープン方法

1. 手でトレイパネルをオープンする場合はギヤを反時計方向に回し続けてディスクトレイが少し前に出てくるようになったらギヤを回すのをやめて、今度はディスクトレイを手で前に引けば出て来ます。(図6)

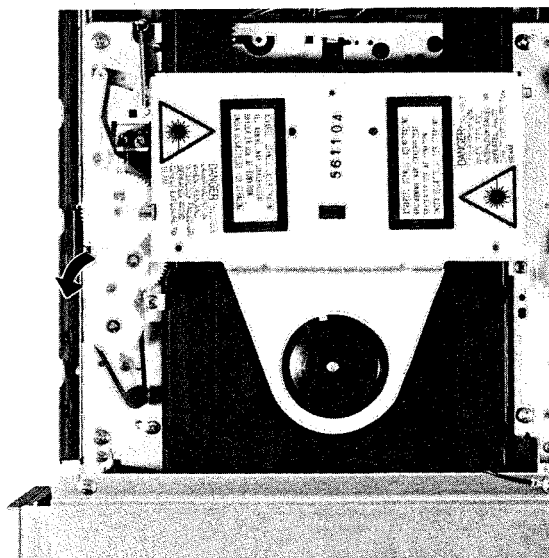

Figure 6
図6

TRAY PANEL REMOVAL

1. Open tray panel.
2. Remove tray panel by pushing hook (C). (Figure 7)

■トレイパネルのはずし方

1. トレイパネルをオープンします。
2. トレイパネルの下側のフックしてある部分 (C) をはずせばはずれます。(図7)

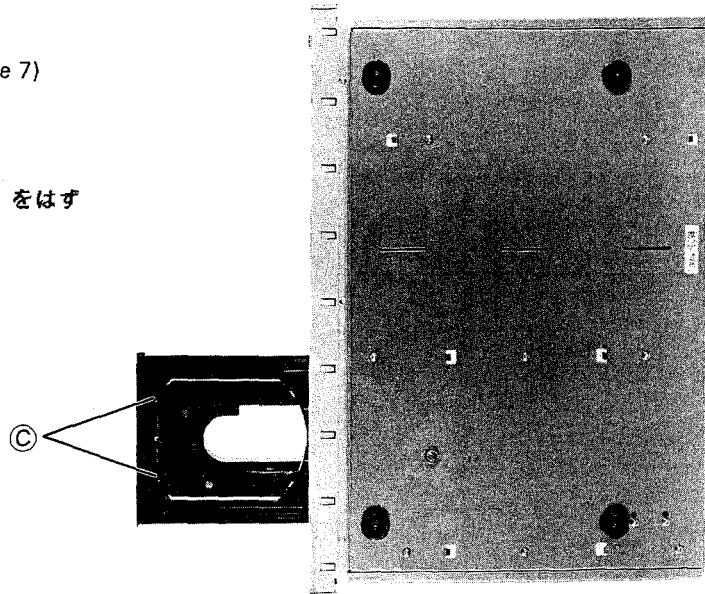

Figure 7

図7

FRONT PANEL REMOVAL

1. Remove tray panel.
2. Remove three screws (D) ($\phi 3 \times 6\text{mm}$), three screws (E) ($\phi 3 \times 6\text{mm}$) and one screw (F) ($\phi 3 \times 6\text{mm}$) and the front panel will be removed from unit. (Figures 8, 9 and 10)

■フロントパネルのはずし方

1. トレイパネルをはずします。
2. 底面のねじ3個 (D) と3個 (E) および (F) 1個をはずし、前に引けばフロントパネルははずれます。(図8, 9, 10)

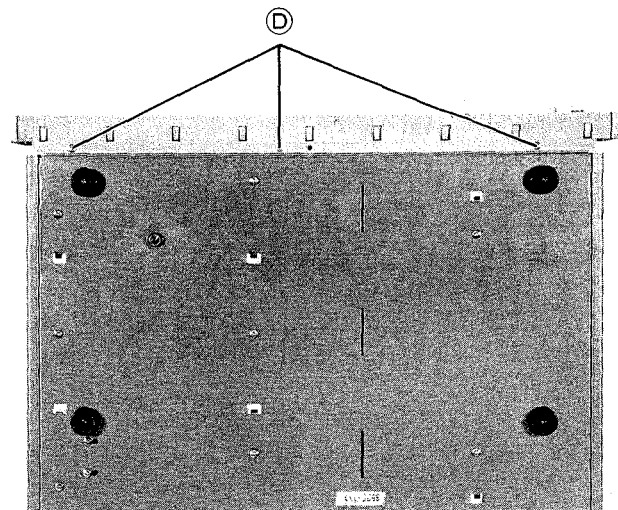

Figure 8

図8

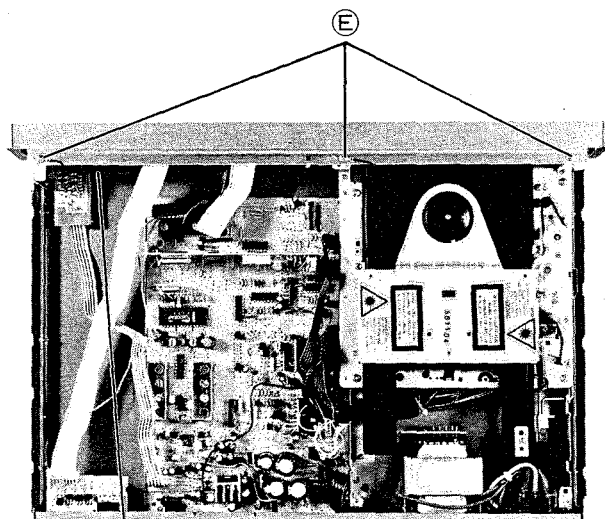

Figure 9

図9



Figure 10

図10

F

MECHANISM ASS'Y REMOVAL

1. Remove front panel.
2. Remove four screws (G) ($\phi 3 \times 6\text{mm}$) and the mechanism ass'y will be removed from unit. (Figure 11)

■メカニズム組立のはずし方

1. フロントパネルをはずします。
2. メカ組立のねじ4個 (G) をはずせばメカ組立ははずれます。(図11)

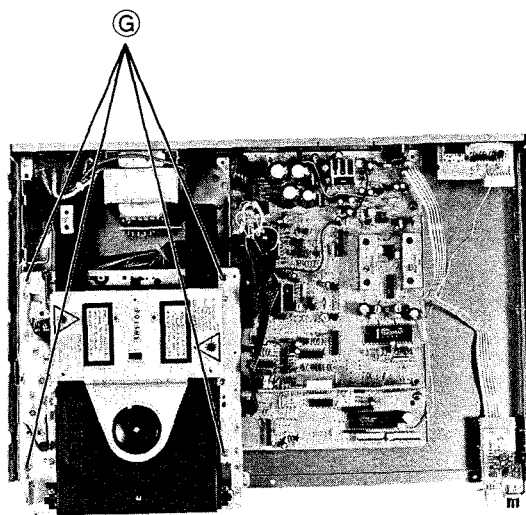

Figure 11

図 11

DISPLAY P.C. BOARD REMOVAL

1. Remove front panel.
2. Remove eight screws (H) ($\phi 3 \times 8\text{mm}$) and, the Display P.C. Board will be removed. (Figure 12)

■ディスプレイPC板のはずし方

1. フロントパネルをはずします。
2. ディスプレイPC板を止めている8本のねじ (H) をはずせばディスプレイPC板ははずれます。(図12)

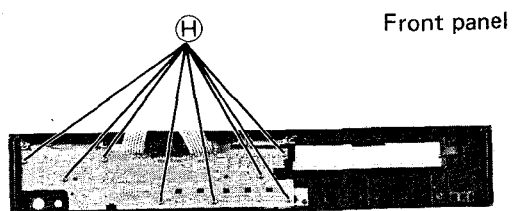
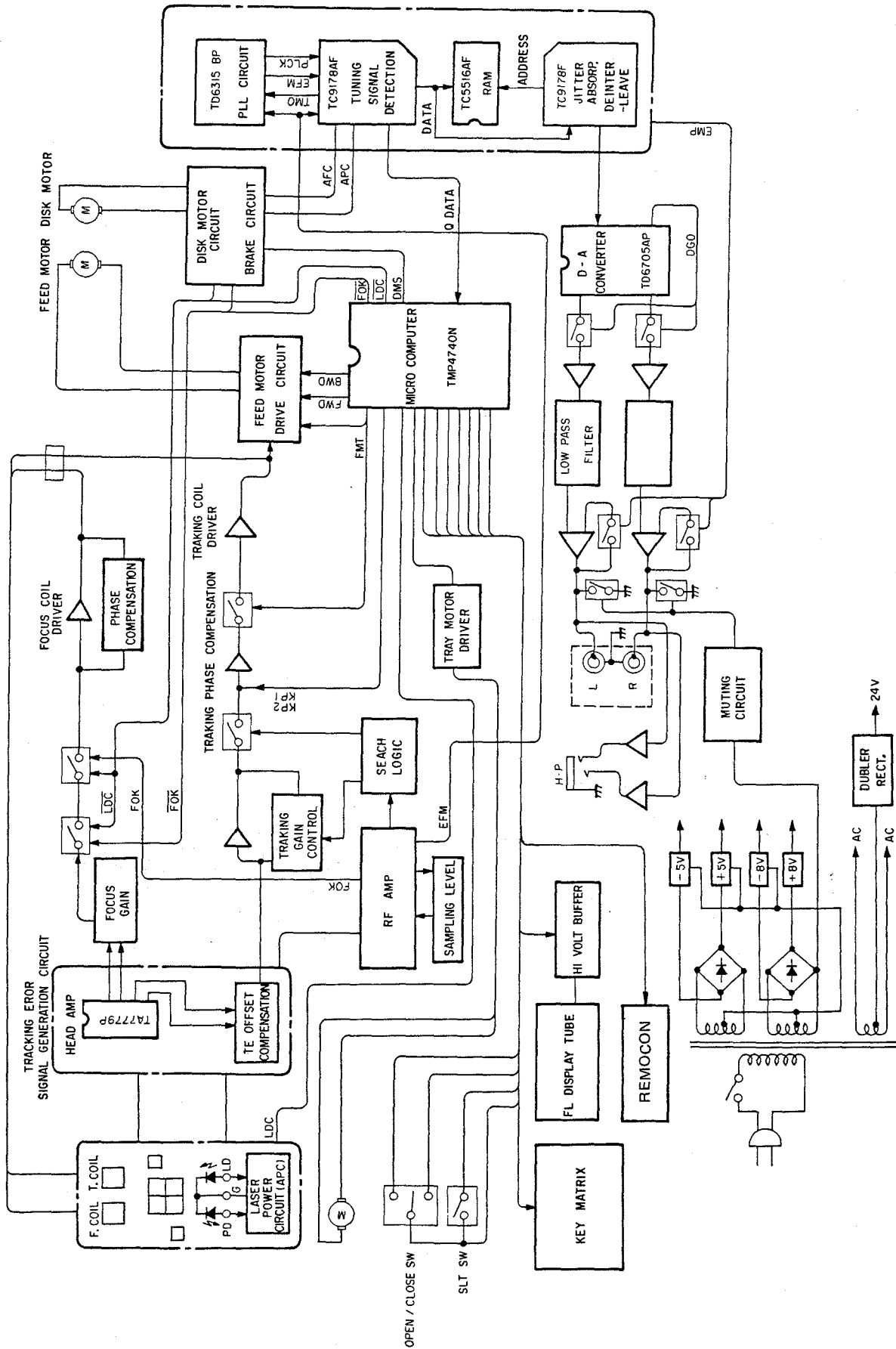

Figure 12

図 12

Block Diagram (ブロックダイアグラム)



Adjustment Locations

Main P.C. Board

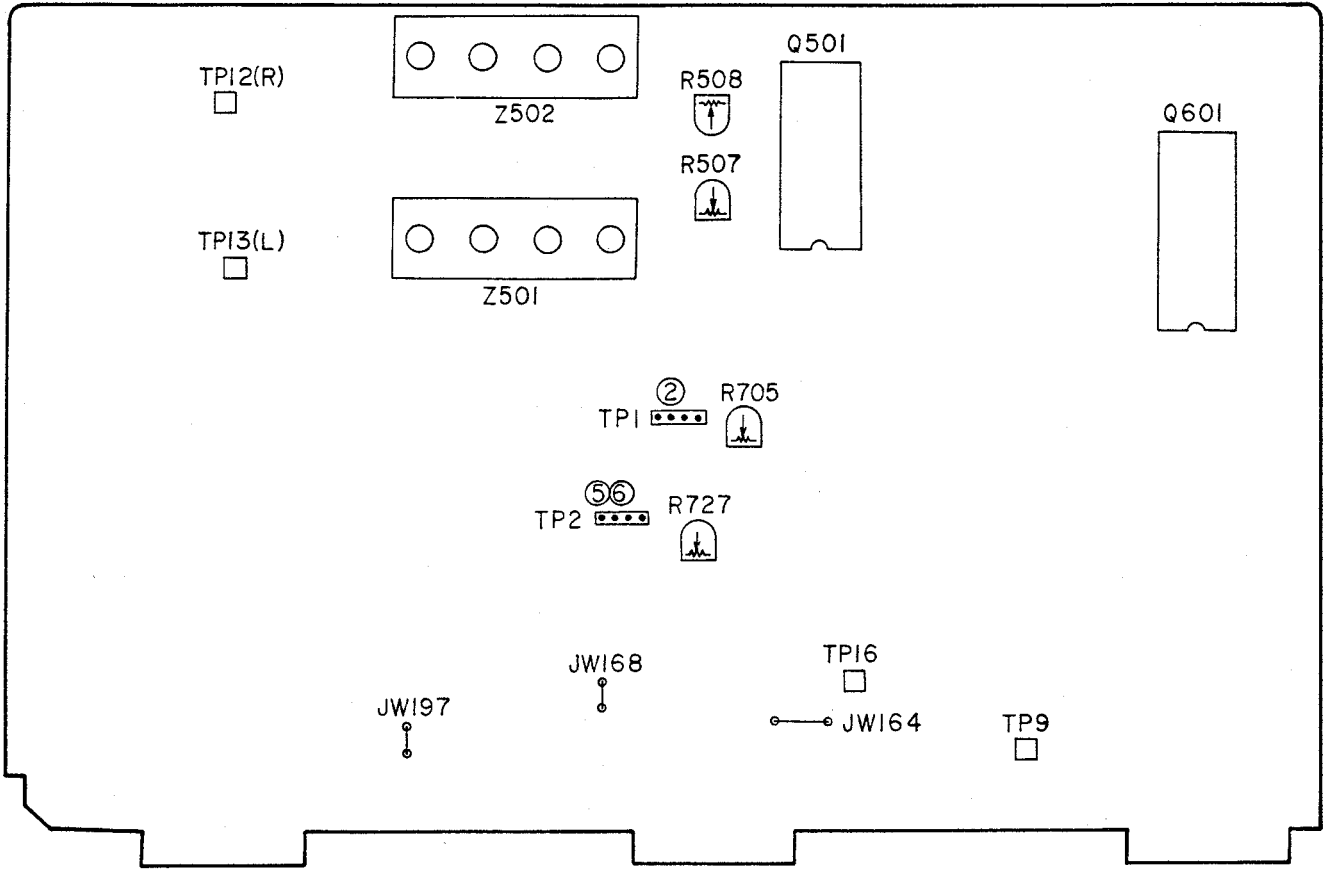

Mechanism APC P.C. Board

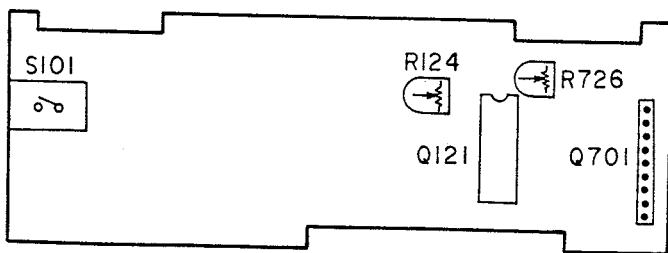

Mechanism P.C. Board

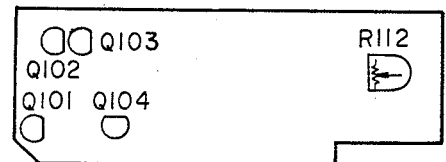

Adjustment Procedures

Adjustment Jigs

1. Laser Power Checker
2. Test Disc A (YEDS 7)
3. Oscilloscope
4. DC Voltmeter
5. Clamper
6. Adjusting Bar (Insulator)

Adjustment Procedures for Pickup Replacement

Step	Measurement Item	Measurement Reference Value	Disc	Operation SW	Test Point	Adjustment Point	Note
1	Laser Power Adjustment	Light Output 270 μ W	Not Loaded	Power ON	Laser Pick-up Lens	Mecha P.C. Board R112	Cut JW164
After adjustment, solder JW164.							
2	Focus Balance Adjustment	RF Amplitude max.	Disc A	PLAY	TP9, TP16	Mecha APC P.C. Board R124	
	Laser Power Fine Adjustment	RF Amplitude 1.0V(p-p)	Disc A	PLAY	TP9, TP16	Mecha P.C. Board R112	
3	Tracking Error Offset Adjustment	DC Offset 0V Center	Disk A	PLAY	TP5, TP6	Mecha APC P.C. Board R726	Cut JW197 → JW168
4	Tracking Gain Adjustment	Tracking Amplitude 0.7V(p-p)	Disc A	PLAY	TP6	Main P.C. Board R727	Cut JW197 → JW168
	Focus Gain Adjustment	Focus Error Amplitude 0.4V	Disc A	PLAY	TP2	Main P.C. Board R705	Cut JW197 → JW168
After adjustment, solder JW197 and JW168.							

Analog Circuit Adjustment

5	DC Offset Adjustment	DC 0V \pm 10mV	Disc A	PLAY	TP13 (L) TP12 (R)	Main P.C. Board R507 (L), R508 (R)	
---	----------------------	------------------	--------	------	----------------------	------------------------------------	--

Preparatory Work Before Adjustment

1. Turn power OFF.
2. Rotate mecha gear, and disc tray will come out. (See Figure 13)
3. When the disc tray comes out fully, raise up clamper lever vertically. (See Figure 14)
4. Remove stopper fitting and mounting screw, and the disc tray will be removed. (See Figure 14)
5. Remove screw at the center of clamper assembly mounted on clamper lever, and remove clamper assembly. Assemble the upper and lower halves of the clamper with the screw and use it as a jig. (See Figures 15 and 16)

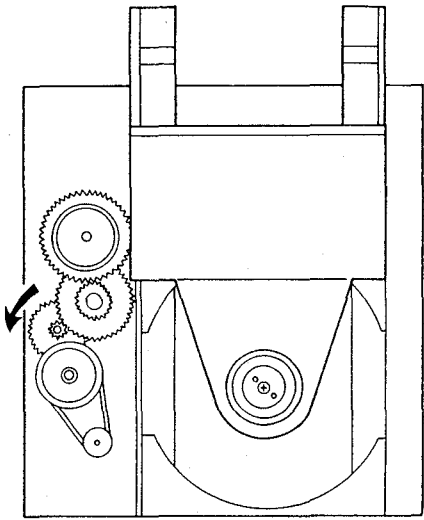

Figure 13

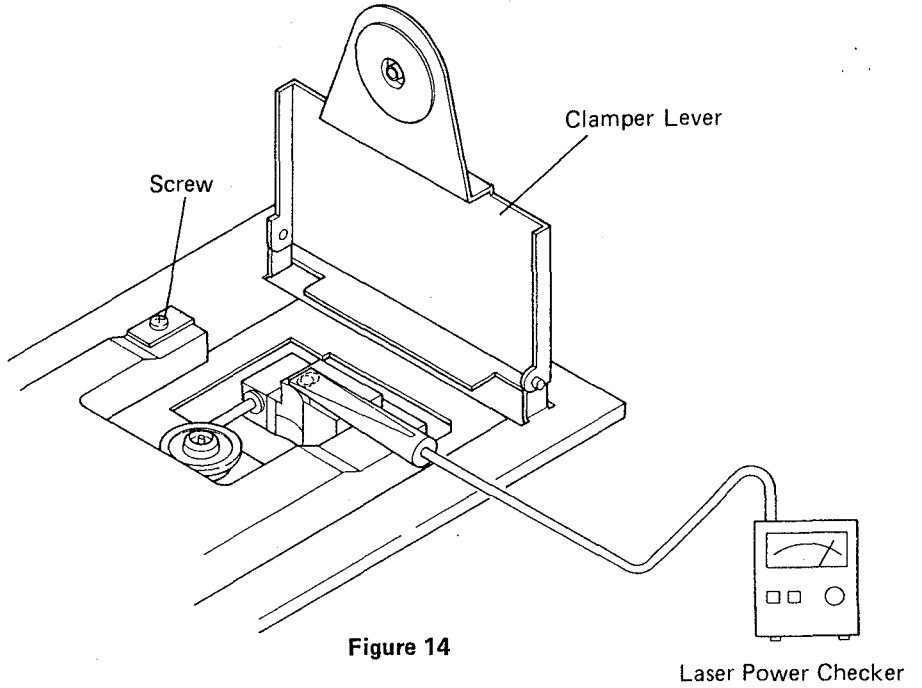

Figure 14

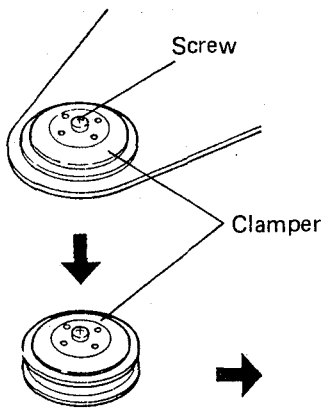

Figure 15

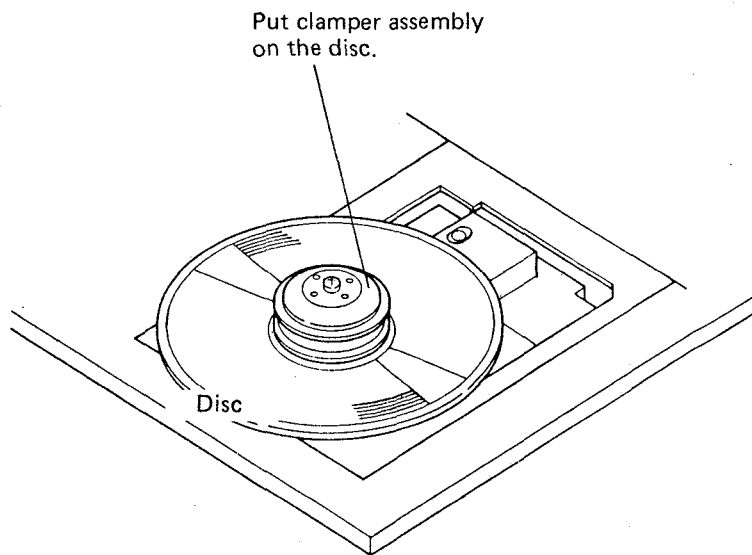



Figure 16

ADJUSTMENT PROCEDURES AFTER LASER PICKUP REPLACEMENT

☆ Hold all semi-fixed resistors (except R112) at their original positions set before replacement of the pickup (almost no adjustment is necessary).

1. LASER POWER ADJUSTMENT

1. Turn power of unit OFF.
2. Turn semi-fixed resistor (R112 10K ohm) at the side of pickup on Mecha P.C. Board counterclockwise  fully. (Laser power min.)
3. Cut JW164 on Main P.C. Board with a nipper [Open laser power control signal L.D.C. (Laser Diode Control).]
4. Remove laser diode protection shorting pin of laser pickup.
5. Turn power of unit ON.
Apply laser power meter sensor to laser pickup lens and adjust R112 by turning clockwise  so that 270μW is obtained. (Take care the laser power meter sensor does not touch surface of the lens.)
6. Turn power of unit OFF.
7. Solder JW164 on Main P.C. Board.

2. FOCUS BALANCE ADJUSTMENT, LASER POWER FINE ADJUSTMENT

1. Remove mecha clamber, put test disc YEDS 7 on disc tray, and secure it with the removed clamber.
2. Check that semi-fixed resistor (R124 20K ohm) on Mecha APC P.C. Board is remained at its original position set before pickup replacement.
3. Connect oscilloscope to TP16 (GND) and TP9 (RF). (AC range: 0.2V/DIV., 0.5μsec/DIV)
4. Turn power of unit ON and play track No. 30 of test disc YEDS 7.
5. Adjust R124 on Mecha APC P.C. Board so that RF amplitude obtains max. (Focus balance adjustment)
6. Adjust semi-fixed resistor, R112 10K ohm on pickup Mecha P.C. Board so that RF amplitude obtains 1.0V (Peak to Peak). (Laser power fine adjustment)

3. TRACKING ERROR OFFSET ADJUSTMENT

1. Check that R726 20K ohm on Mecha APC P.C. Board is remained at its original position set before pickup replacement.
2. Turn power of unit ON and play track No. 11.
(Note: If R726 on Mecha APC P.C. Board is out of position excessively, normal play operation can not be expected.)
3. Cut JW197 (feeding motor) and JW168 (tracking) in this order with a nipper.
4. Connect oscilloscope to TP5 (GND) and TP6 (tracking error signal) on Main P.C. Board. (DC range: 0.2V/DIV., 5msec/DIV.)
5. Adjust semi-fixed resistor R726 20K ohm on Mecha APC P.C. Board so that DC offset of tracking error signal obtains 0V.
6. Hold the unit under the same condition to proceed next adjustment of tracking and focus servo gain.

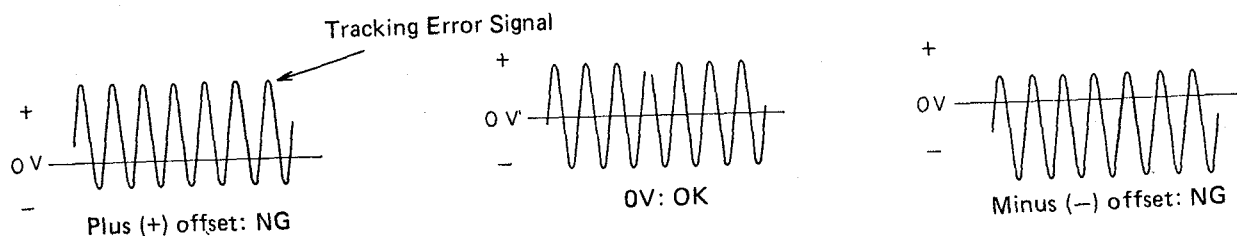

Figure 17

4. TRACKING AND FOCUS GAIN ADJUSTMENT

1. Check that semi-fixed resistor R705 10K ohm (focus gain) and R727 10K ohm (tracking gain) on Main P.C. Board when being unable to check positions, set both R705 and R727 at the center are remained at their original positions set before pickup replacement.

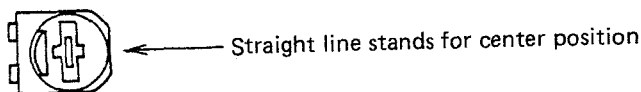

Figure 18

- Adjust R727 so that tracking error amplitude at TP6 obtains 0.7V (Peak to Peak).



Figure 19

- Adjust R705 so that amplitude obtains 0.4V (Peak to Peak) with oscilloscope connected to TP2 (focus error signal).

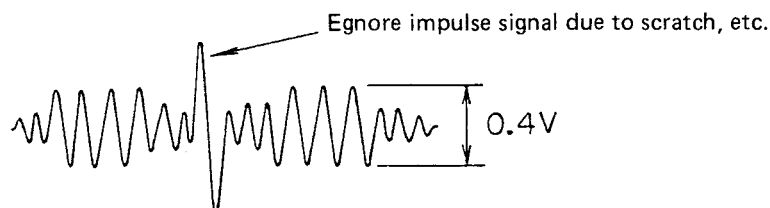

Figure 20

- Turn power of unit OFF.
Solder JW197 and JW168 on Main P.C. Board.

5. ANALOG OUTPUT OFFSET ADJUSTMENT

This adjustment is not related with pickup replacement.

- Turn power of unit ON.
- Connect DC voltmeter or oscilloscope to TP13, L ch and TP12, R ch on Main P.C. Board.
Adjust semi-fixed resistors R507 10K ohm (L ch) and R508 10K ohm (R ch) so that (DC range) offset voltage obtains $0V \pm 10mV$.

■ **LASER PICKUP**

Caution for laser pickup removal.

1. When removing the laser pickup, solder and short-circuit the terminals to which red and black leads are connected to protect the laser pickup from damage which may be caused during the removal. (Refer to Figures 21 and 22)
2. Disconnect the connector and leads after completion of soldering. Do not touch the terminals on the pickup by your hand.
3. When mounting the laser pickup, first connect the connector and leads and then unsolder the short-circuit terminals.

■ **CAUTION FOR LASER PICKUP REPLACEMENT**

1. When mounting a new laser pickup, first connect the connector and leads and then remove laser diode protection shorting pin on P.C. Board. (Refer to Figures 23 and 24.)

- * Use a soldering iron grounded (or leakageless iron).
- * Cover the working bench with a conductive mat which is also grounded.
- * Before proceeding job, always touch the conductive mat or ground lead with your both hands to discharge electric charges developed on your body.

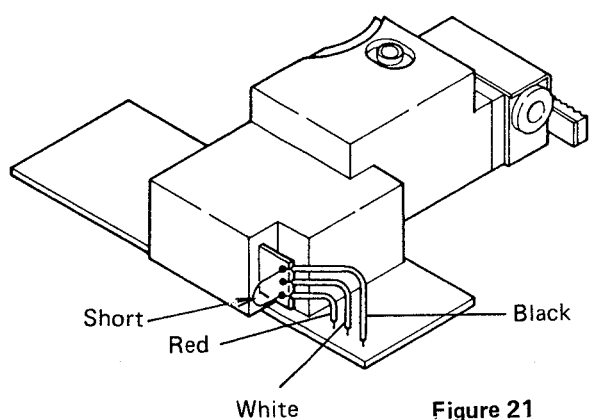

Figure 21

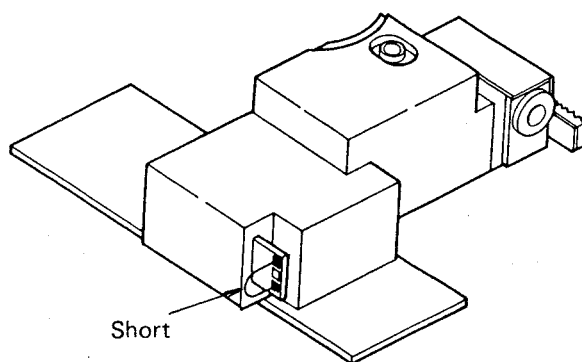
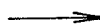

Figure 22

- Solder and short-circuit the two terminals before disconnecting leads from flexible P.C. Board.

- Terminals short-circuited.

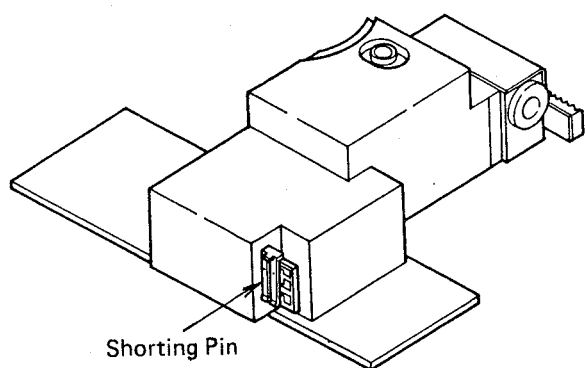

Figure 23

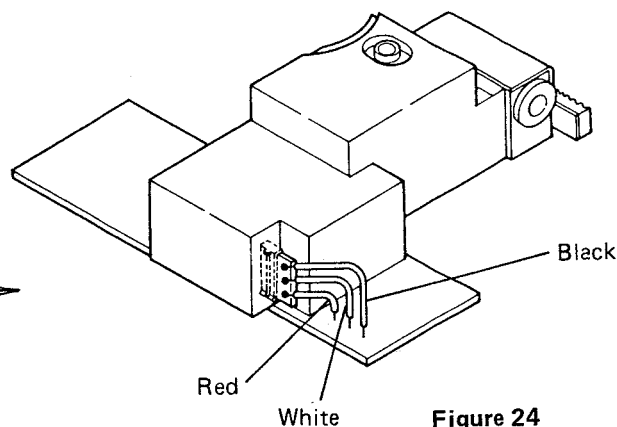
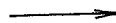

Figure 24

- Laser diode protection shorting pin.

- Remove laser diode protection shorting pin after connection of leads to flexible P.C. Board has been completed.

■ LASER PICKUP RANK INDICATION

- The pickups are divided into two rank groups, A and B, and the rank is indicated on a label put on a side of the pickup as shown in Figure 25. When replacing by a new pickup of the same rank as the pickup to be replaced, no additional resistor replacement is required. However, when replaced by a new pickup of a different rank, a resistor must be replaced as tabulated below, according to the rank of a new pickup.

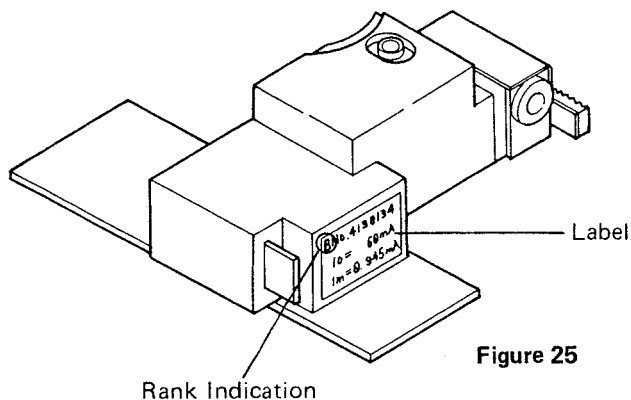

Figure 25

Rank	Symbol No.	R113
A		Remove
B		5.6K

■ LASER PICKUP REPLACEMENT

1. Remove flexible P.C. Board from connector (T) of mecha APC P.C. Board.
2. Remove two screws (Z), and the laser pickup and mecha P.C. Board will be removed. (Remove shaft as well.)
3. Unsolder pins 4 and 11 of laser pickup flexible P.C. Board, and the flexible P.C. Board will be removed.
4. Short-circuit laser pickup's two terminals to which red and black leads are connected and disconnect three leads. (Refer to laser pickup.)
5. Remove two screws (Y), and the mecha P.C. Board (X) will be removed.
6. Remove two screws (U), and lack spring will be removed.
7. Remove two screws (R) and (S), and the guide lever assembly will be removed. (Do not move spring and screw on guide lever.)
8. The laser pickup will be replaced in this way. Reassemble in reverse steps 1 to 7 above.

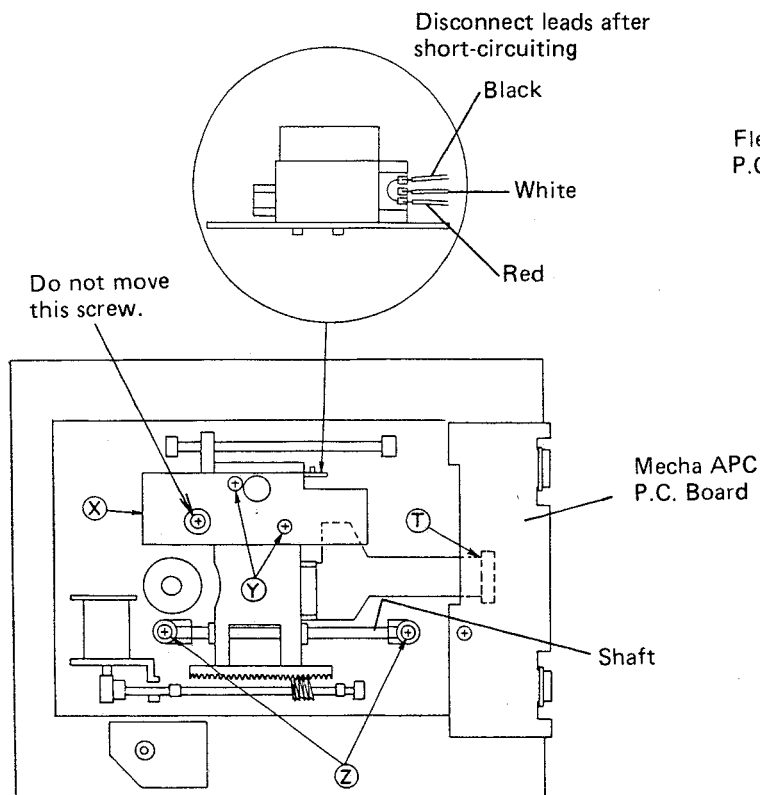

Figure 26

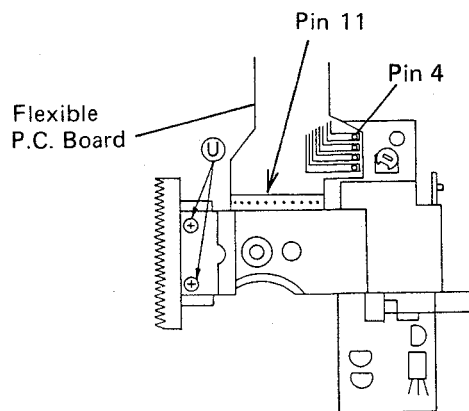

Figure 27

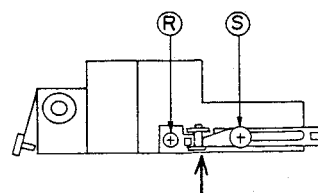

Figure 28

■ CAUTION FOR CAM GEAR AND DRIVE GEAR REPLACEMENT

1. When mounting cam gear and drive gear, first adjust the gears so that cam gear's mark and a dot of drive gear A are positioned in line as shown below, and then insert cam gear so that protruding part of cam gear slides into cam link.

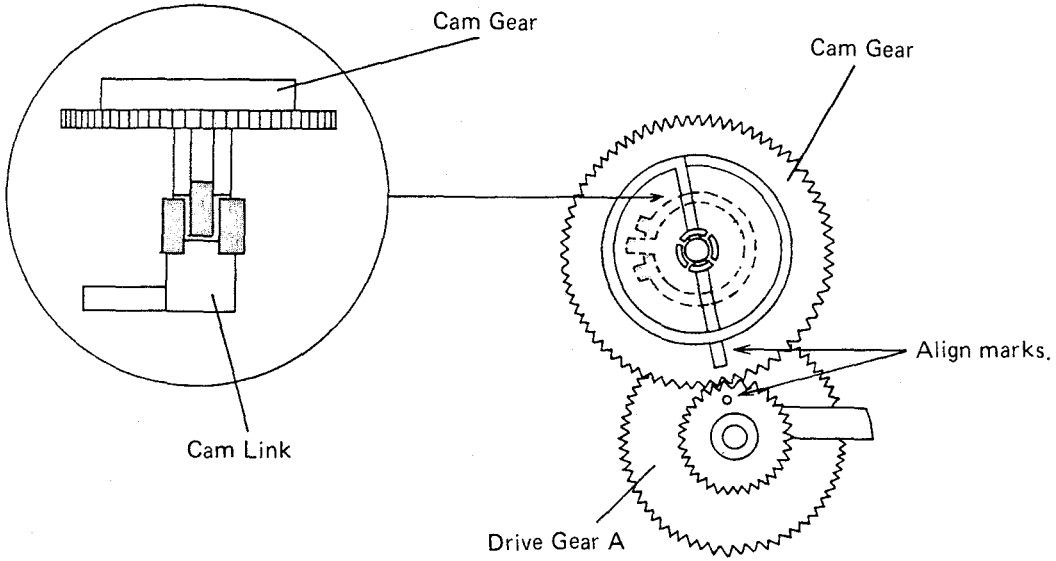

Figure 29

■ CAUTION FOR DISC TRAY INSERTION

1. When inserting disc tray, adjust clamber lever and cam gear so that the lever shaft and the mark of the gear are positioned as illustrated. After insertion, open clamber lever and mount stopper fitting.

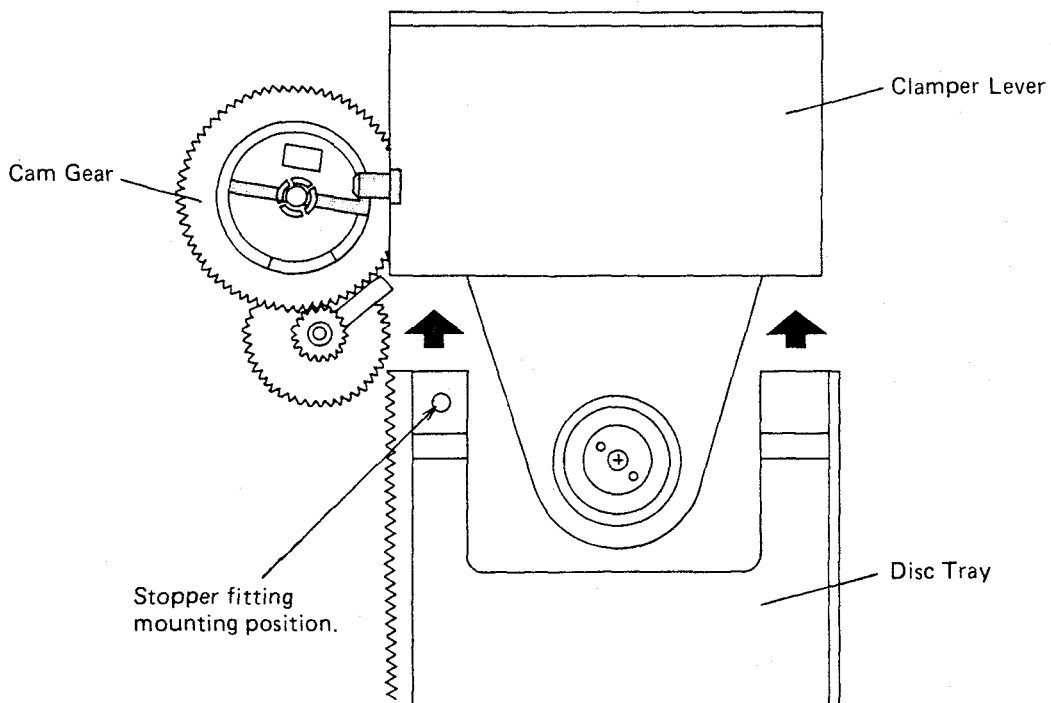
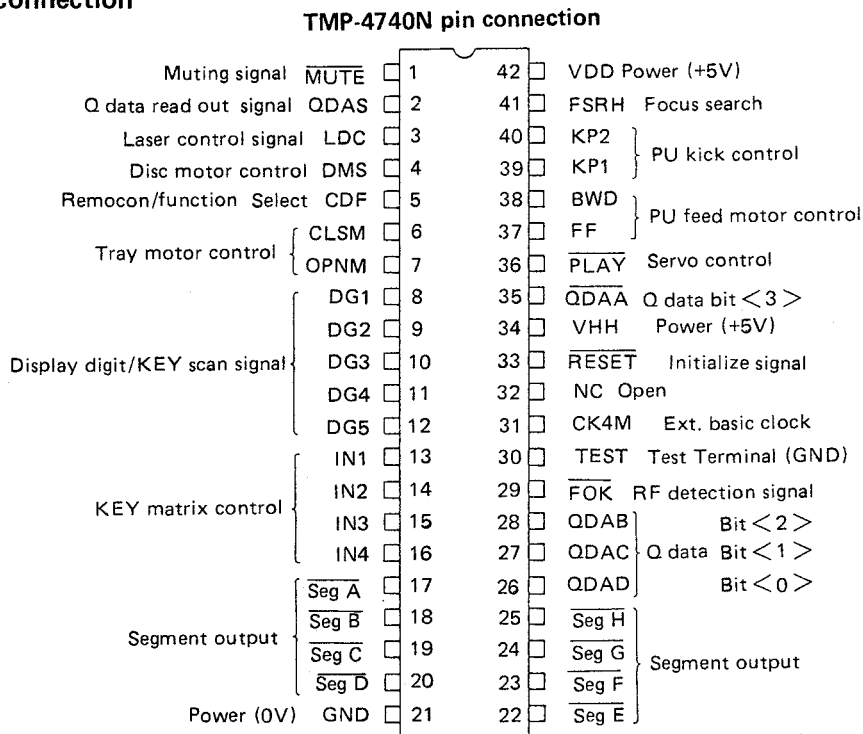
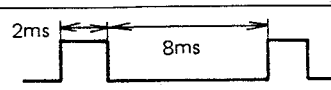

Figure 30

■ TMP4740N pin connection



TMP4740N Terminals Function

Pin No.	Port Name	Signal Name	Input & Output	Initial Value	Function	
1	R4	R40	MUTE	Output	L	Muting output Muting ON at "L". "H" at PLAY mode only, "L" at the other modes.
2		R41	QDAS	Output	L	1. Q-DATA/Error status select signal. 2. Q-DATA read-out signal.
3		R42	LDC	Output	L	Laser control signal. Laser OFF at "L", Laser ON at "H".
4		R43	DMS	Output	L	Disc motor control signal. Motor stops at "L".
5	R5	R50	CDF	I/O	H/L	Successive operation depend upon SW in key matrix. 1. Wired remocon data input. 2. Function switch signal output.
6		R51	CLSM	Output	H	Tray motor control signal. "L" during tray opening.
7		R52	OPNM	Output	H	Tray motor control signal. "L" during tray closing.
8		R53	DG1	Output	L	Display digit select signal.  Select at "H".
9	R6	R60	DG2	Output	L	1. Display digit select signal. 2. KEY matrix scan signal.
10		R61	DG3	Output	L	Same as above.
11		R62	DG4	Output	L	Same as above.
12		R63	DG5	Output	L	Same as above.

Pin No.	Port Name	Signal Name	Input & Output	Initial Value	Function	
13	R7	R70	IN1	Input	*	KEY matrix input.
14		R71	IN2	Input	*	Same as above.
15		R72	IN3	Input	*	Same as above.
16		R73	IN4	Input	*	Same as above.
17	P1	P10	Seg A	Output	H	Display segment DATA output ON at "Low" level 1. a segment 2. Colon
18		P10	Seg B	Output	H	Display segment DATA output ON at "Low" level 1. b segment 2. PAUSE indicator
19		P12	Seg C	Output	H	Display segment DATA output ON at "Low" level 1. c segment
20		P13	Seg D	Output	H	Display segment DATA output ON at "Low" level 1. d segment 2. REPEAT indicator
22	P2	P20	Seg E	Output	H	Display segment DATA output ON at "Low" level 1. e segment 2. TNO indicator
23		P21	Seg F	Output	H	Display segment DATA output ON at "Low" level 1. f segment 2. LAP indicator
24		P22	Seg G	Output	H	Display segment DATA output ON at "Low" level 1. g segment 2. REM indicator
25		P23	Seg H	Output	H	Display segment DATA output ON at "Low" level 1. MEMORY indicator
26	K0	K00	QDAD	Input	*	Q-DATA/Error status DATA input
27		K01	QDAC	Input	*	Same as above.
28		K02	QDAB	Input	*	Same as above.
29		K03	FOK	Input	*	RF detection signal input. RF signal at "L".
35	R8	R80	QDAA	Input	*	1. Q-DATA read-out enable signal input. 2. Q-DATA input.
36		R81	PLAY	Output	H	Servo control signal. Servo ON at "L".
37		R82	FF	Output	L	PU feed motor control. PU moves outward at "H".
38		R83	BWD	Output	L	PU feed motor control. PU moves inward at "H".
39	R9	R90	KP1	Output	L	PU kick control. FWD kick at "H".
40		R91	KP2	Output	L	PU kick control. BWD kick at "H".
41		R92	FSRH	Output	L	Focus search signal. If LDC is "H", input 1 Hz pulse.
21		Vss	GND			Power (0V)
30		TEST	TEST	Input		Test mode setting input. Connect to GND.
31		XIN	CK4M	Input		External basic clock input.
32		XOUT		Output		Open
33		RESET	TESET	Input		Initialize signal input. Initialize function at "L".
34		VHH	VHH			Memory back up power. Connect to VDD.
42		VDD	VDD			Power (+5V)

調整箇所

メインPC板

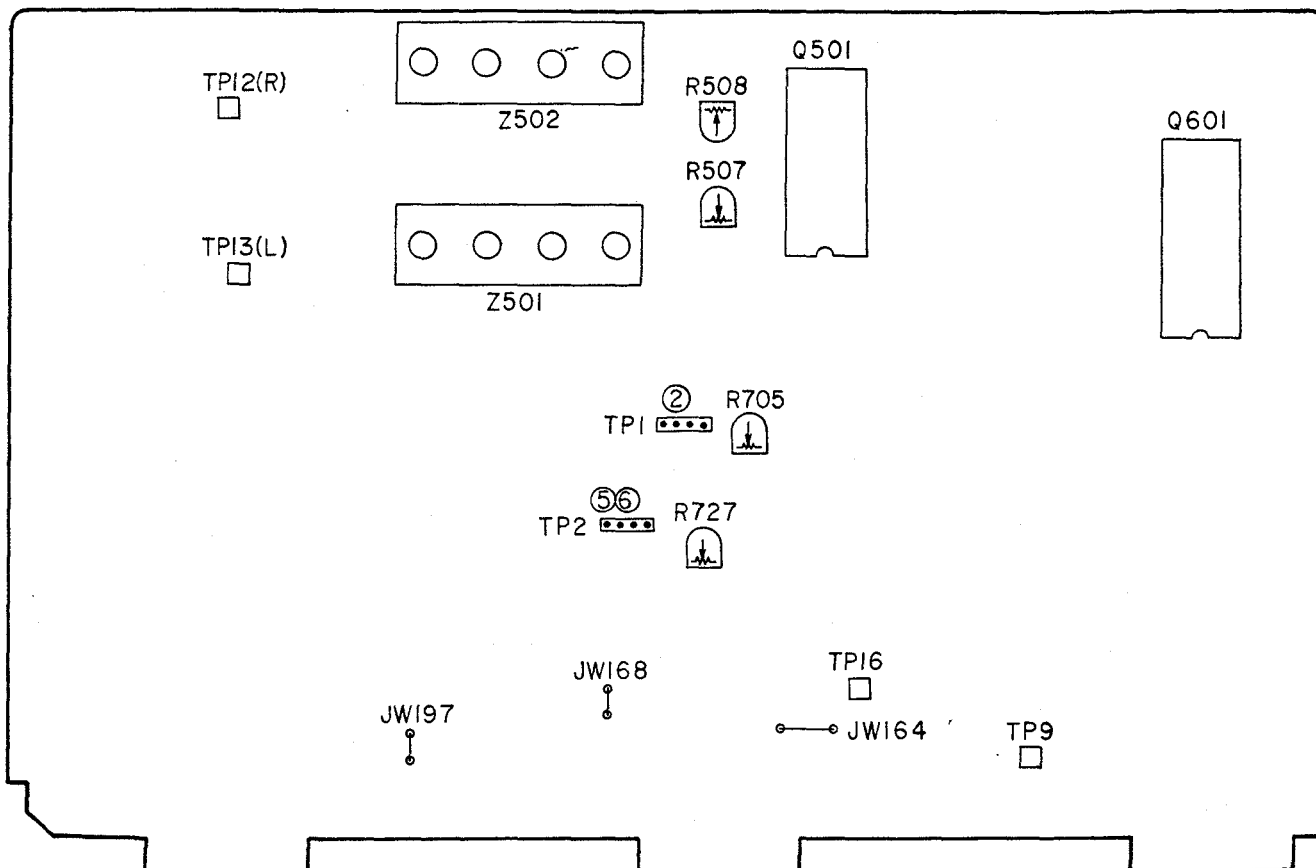

メカニズムAPC PC板

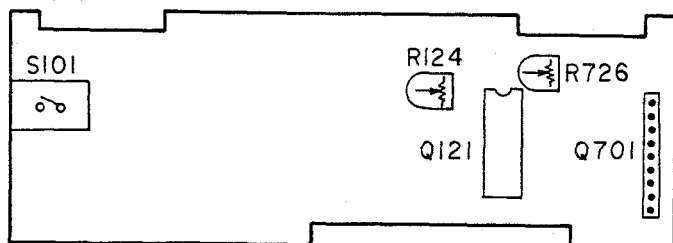

メカニズムPC板

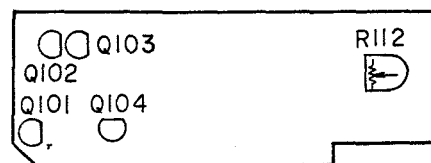

調整方法

治具

1. レーザーパワーチェッカー
2. テストディスクA (YEDS7)
3. オシロスコープ
4. DCボルトメーター
5. クランパー
6. 調整棒 (絶縁体)

ピックアップ交換時の調整手順

ステップ	測定項目	測定基準値	ディスク	操作スイッチ	テストポイント	調整箇所	備考
1	レーザーパワー調整	光出力 270 μ W	無	電源ON	レーザーピックアップレンズ	メカPC板 R112	JW164 カット
調整後はJW164を接続します。							
2	フォーカス バランス調整	RF振幅 最大	ディスクA	PLAY	TP9, TP16	メカAPC PC板 R124	
	レーザーパワー 微調整	RF振幅 1.0V _{p-p}	ディスクA	PLAY	TP9, TP16	メカPC板 R112	
3	トラッキング エラー オフセット調整	DCオフセット 0V中心	ディスクA	PLAY	TP5 TP6	メカAPC PC板 R726	JW197→ JW168 カット
4	トラッキング ゲイン調整	トラッキング 振幅 0.7V _{p-p}	ディスクA	PLAY	TP6	メインPC板 R727	JW197→ JW168 カット
	フォーカス ゲイン調整	フォーカス エラー振幅 0.4V	ディスクA	PLAY	TP2	メインPC板 R705	JW197→ JW168 カット
調整後はJW197, JW168を接続します。							

アナログ回路調整

ステップ	測定項目	測定基準値	ディスク	操作スイッチ	テストポイント	調整箇所	備考
5	DCオフセット 調整	DC 0V \pm 10mV	ディスクA	PLAY	TP13 (L) TP12 (R)	メインPC板 R507 (L) R508 (R)	

■調整前の準備

1. 電源をOFFの状態にしておきます。
2. メカのギヤを回しディスクトレイを前に出します。(図13)
3. ディスクトレイが一杯出たらクランパーレバーを垂直にたてます。(図14)
4. ディスクトレイのストッパー金具と取付ねじをはずしディスクトレイを前に取り出します。(図14)
5. クランパーレバーについているクランパー組立のねじをはずし、クランパー組立をはずしておきます。上下にはずれたクランパーをねじで組立にして治具として利用します。(図15, 16)



図13



図14

レーザーパワー
チェッカー

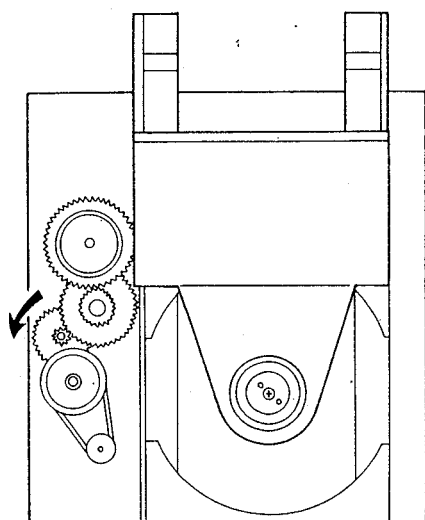

図15

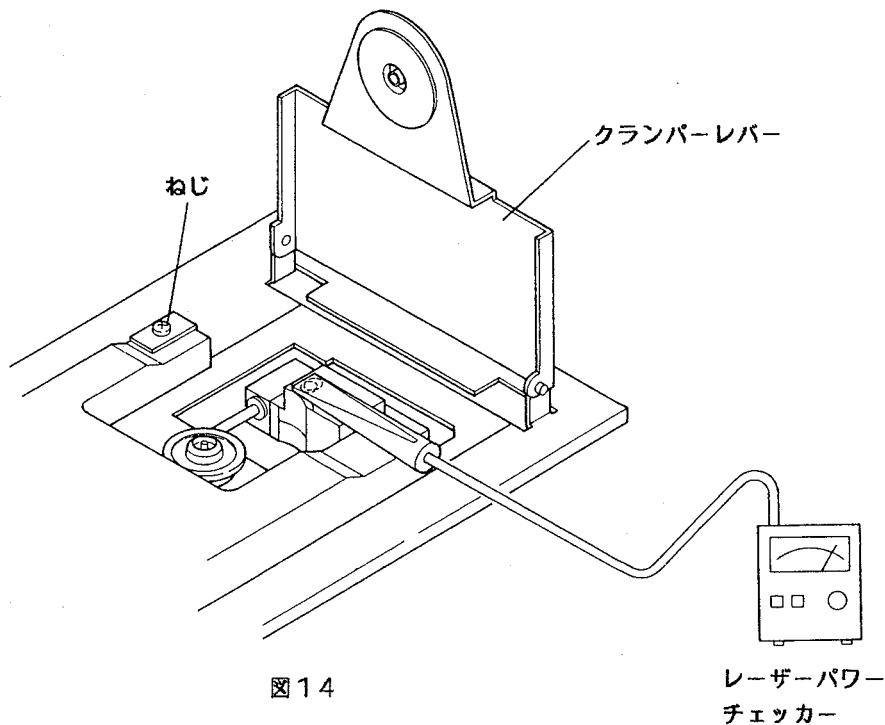

図16

■レーザーピックアップ交換後の調整方法

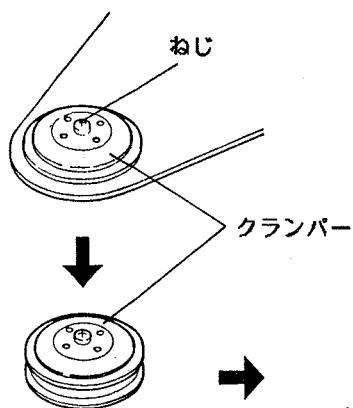
☆半固定抵抗はR112を除き他は全てピックアップ交換前の位置にしておきます。(調整がほとんど必要ありません。)

1. レーザーパワー調整

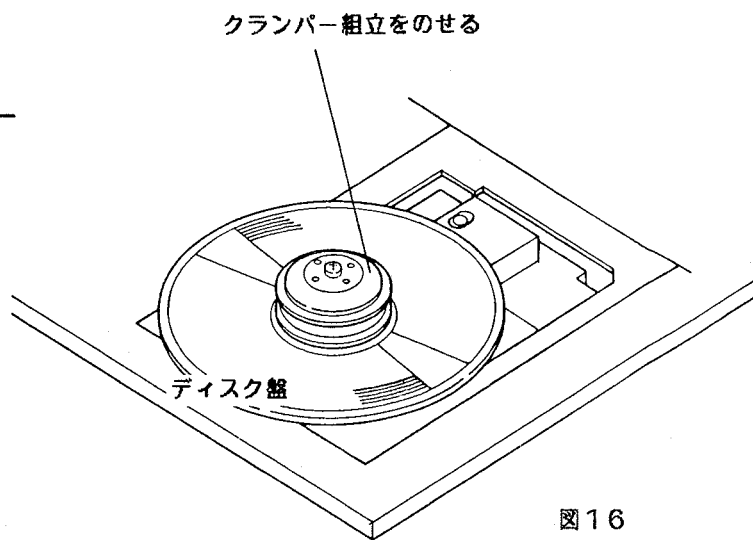
1. セット電源をOFFにしておきます。
2. ピックアップ横の半固定メカPC板のR112 10K Ω を半時計方向一杯に回します。(レーザーパワー最小)
3. メインPC板JW164をニッパー等でカットします。
[レーザーパワーコントロール用信号L. D. C (Laser Diode Control)をオープンにする。]
4. レーザーピックアップのレーザーダイオード保護用ショートピンをはずす。
5. セット電源をONにし、レーザーパワーメーターのセンサー部をピックアップ上面に添わせ270 μ Wになる様メカPC板R112を時計方向 \curvearrowright へ回し調整します。(レンズ面にセンサー部が触れないように注意します。)
6. セット電源をOFFにします。
7. メインPC板のJW164をハンダ付けで接続する。

2. フォーカスバランス調整、レーザーパワー微調整

1. メカランバーをはずし、テストディスクYEDS7を乗せ、はずしたランバーで押さえます。
2. メカAPC PC板の半固定R124 20K Ω をピックアップ交換前の位置にある事を確認します。
3. TP16 (GND), TP9 (RF)にオシロを接続します。(ACレンジ 0.2V/DIV, 0.5 μ sec/DIV)
4. セット電源をONにし、テストディスクYEDS7のトラックNo. 30をPLAYします。
5. RF振幅が最大になるようにメカAPC PC板R124を調整します。(フォーカスバランス調整)
6. RF振幅が1.0V (Peak to Peak)になるようにピックアップメカPC板の半固定R112 10K Ω を調整します。(レーザーパワー微調整)

3. トラッキングエラーオフセット調整

1. メカAPC PC板のR726 20K Ω がピックアップ交換前の位置にある事を確認します。
2. セットの電源をONにし、トラックNo. 11をPLAYします。
(注意: メカAPC PC板R726が極端にずれている場合には、PLAYする事ができません。)
3. JW197 (送りモーター), JW168 (トラッキング)を順番にニッパー等でカットします。必ずJW197を先にカットします。
4. メインPC板のTP5 (GND), TP6 (トラッキングエラー信号)にオシロを接続します。
(DCレンジ 0.2V/DIV, 5msec/DIV)
5. トラッキングエラー信号のDCオフセットが0VになるようにメカAPC PC板の半固定R726 20K Ω を調整します。
6. トラッキング、フォーカサーボゲイン調整のため、このままの状態にしておきます。



図17

4. トラッキング、フォーカスゲイン調整

1. メインPC板の半固定R705 10K Ω (フォーカスゲイン), R727 10K Ω (トラッキングゲイン) をピックアップ交換前の位置にある事を確認します。位置がわからない場合は, R705, R727 とともに中央にセットしておきます。

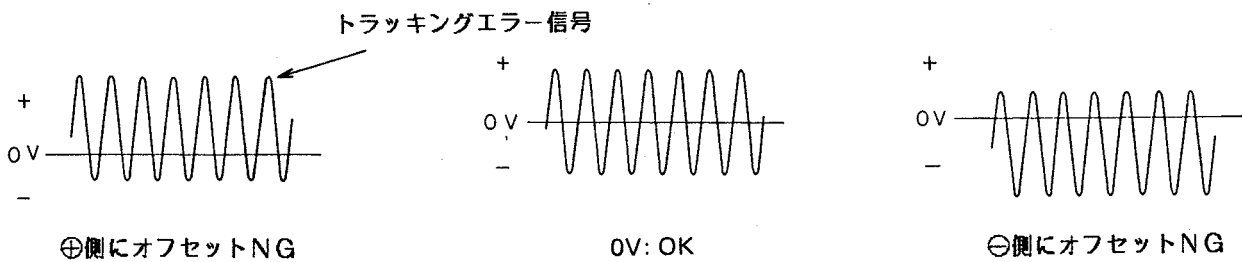

図18

2. TP6のトラッキングエラー振幅が 0.7V (Peak to Peak) になるようにR727 を調整します。

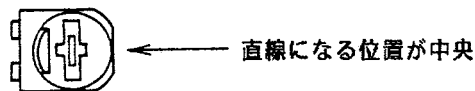

図19

3. オシロをTP2のフォーカスエラー信号に接続し, 振幅が 0.4V (Peak to Peak) になるようにR705 を調整します。



図20

4. セット電源をOFFにし, メインPC板のJW197, JW168 をハンダ付けで接続します。

5. アナログ出力オフセット調整

この調整はピックアップ交換時には, 関係ありません。

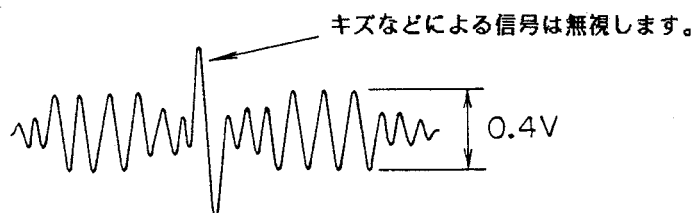
1. セットの電源をONにします。
2. メインPC板のTP13, Lch, TP12, Rch にDC電圧計, あるいはオシロを接続し, (DCレンジ) オフセットが $0V \pm 10mV$ になるように, 半固定R507 10K Ω (Lch), R508 10K Ω (Rch) を調整します。

■レーザーピックアップについて

修理時レーザーピックアップをはずす時の注意

1. レーザーピックアップを取りはずす時には、赤と黒のリード線が接続されている端子をハンダ付けしてショートします。それは、ピックアップ取りはずしの作業中起こるかもしれないレーザーピックアップの破損を防ぐためです。(図21, 22参照)
2. ハンダ付けが完全に終わったらコネクタとリード線ははずします。ピックアップの端子には手を触れないように注意してください。
3. レーザーピックアップを取り付ける時には、コネクタとリード線を付けてから、ショートしたハンダ付けをはずしてください。

■レーザーピックアップ交換時の注意

1. 新しいレーザーピックアップを交換する時には、コネクタにリード線を接続してから、PC板のレーザーダイオード保護用ショートピンをはずしてください。(図23, 24)
- * アースされたはんだごて(または漏電のないはんだごて)を使用してください。
 - * アースされた漏電マットで作業台をおおってください。
 - * 作業を始める前には、いつも両手で漏電マットやアース線に触れて身体に帯電しないようにしてください。



図21



図22

- フレキPC板及びリード線をはずす前に2本の端子をはんだ付けしてショートします。

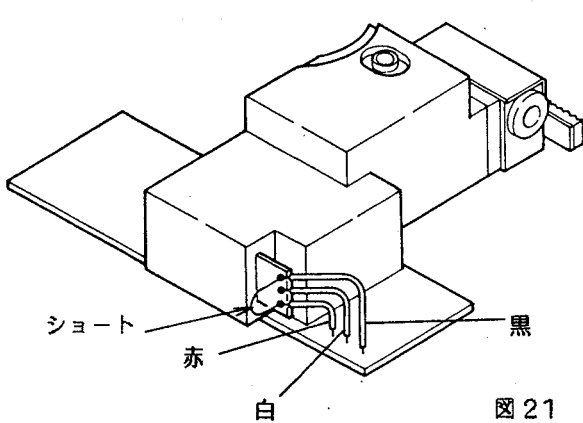
- ショートされた状態の端子

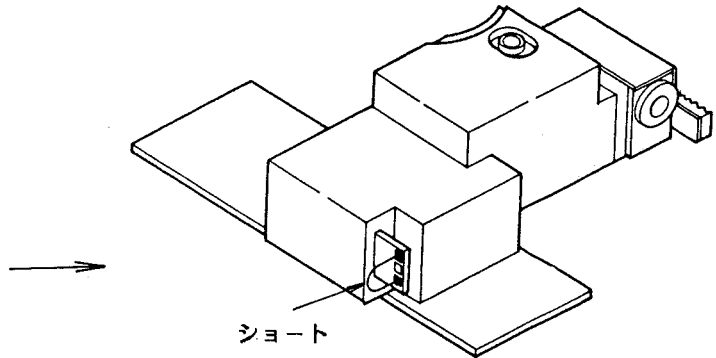

図23



図24

- レーザーダイオード保護用ショートピン

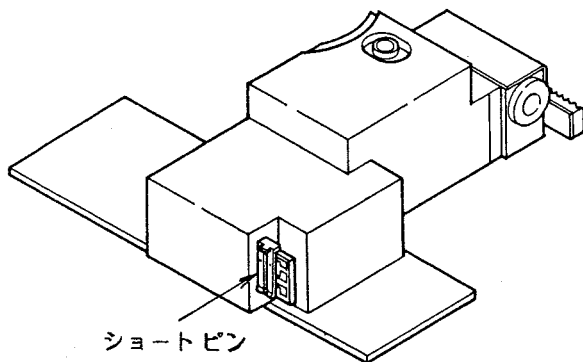
- フレキPC板とリード線の接続が完了した後、レーザーダイオード保護用ショートピンをはずします。

■レーザーピックアップランク表示

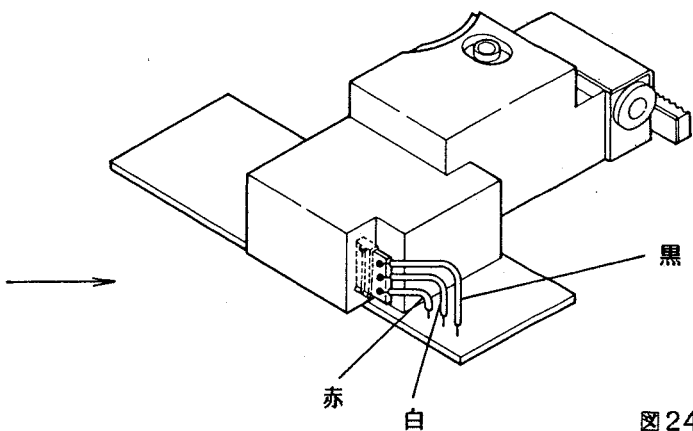
ピックアップはA、Bのふたつのグループのランクに分けられ、図25のようにピックアップの側面に貼ってあるラベルにランクが表示されています。取り換えるピックアップと新しく取り付けるピックアップのランクが同じ場合には、さらに抵抗を取り換える必要はありません。違うランクのピックアップを交換する時には、下表に示されているように、新しく取り付けるピックアップのランク従って抵抗を取り換えなくてはなりません。



図 25

部品NO.	R113
ランク	
A	取り除く
B	5.6K

■レーザーピックアップの交換のしかた

1. メカAPC PC板のコンネクター ① よりフレキPC板を抜きます。
2. ネジ ② 2本をはずしレーザーピックアップとメカPC板をはずします。(軸も抜きます。)
3. レーザーピックアップのフレキPC板の11ピンと4ピンのハンダ付けをはずしてフレキPC板をはずします。
4. 図のようにレーザーピックアップの赤と黒のリード線が出ている両端をショートしてから、リード線3本をはずします。
(レーザーピックアップについての項参照)
5. ネジ ⑤ 2本をはずし、メカPC板 ④ をはずします。
6. ネジ ⑩ 2本をはずし、ラックスpringをはずします。
7. ネジ ⑧, ⑨ 2本をはずし、ガイドレバー組立をはずします。
(ガイドレバーについているspringのはいったネジは、絶対に動かさないでください。)
8. 以上でレーザーピックアップが交換できます。組み立てる時は逆の順に組み立ててください。

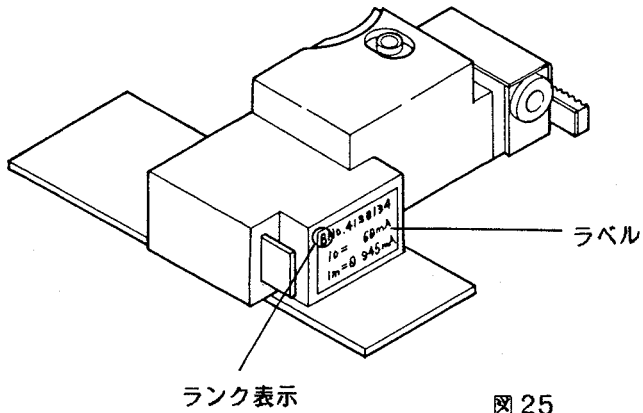
ショートしてからリード線ははずすこと



図26



図27

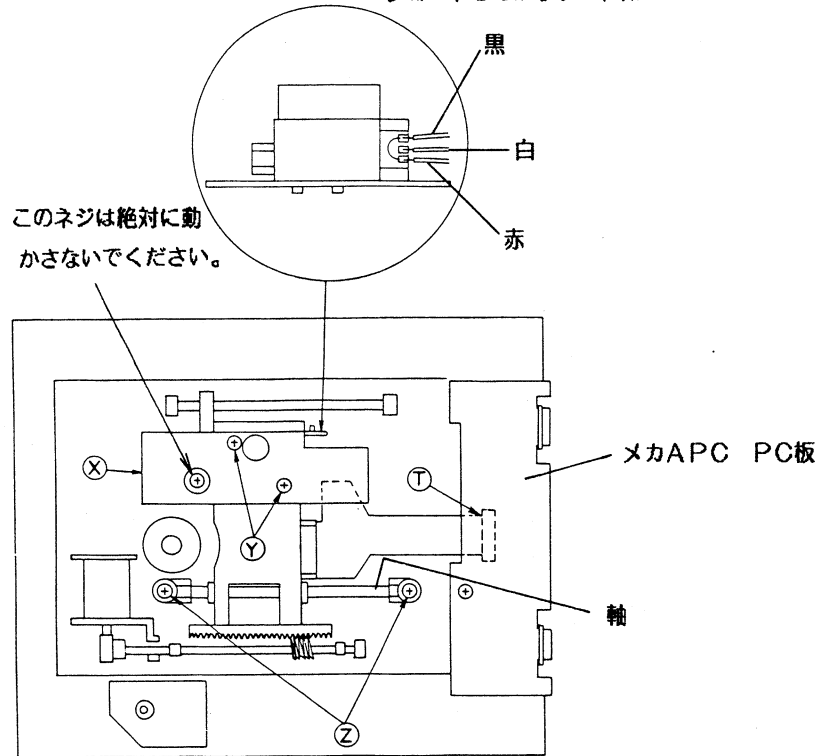

図28

■カムギヤ、ドライブギヤ交換時の注意

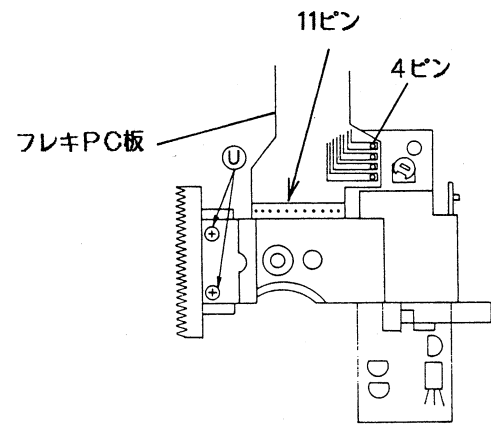
1. カムギヤ、ドライブギヤを取り付ける時は、カムギヤの印とドライブギヤ-Aの丸い印が合わさるようにし、さらにカムギヤの突起部がカムリンクの間に入るように挿入してください。

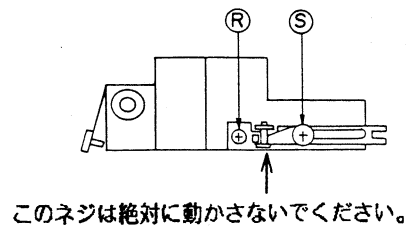

図29

■ディスクトレイ挿入時の注意

1. ディスクトレイを挿入する時は、クランパーレバーの軸とカムギヤの印が図の位置の時、挿入してください。挿入したらクランパーレバーを開きストッパー金具を取り付けます。

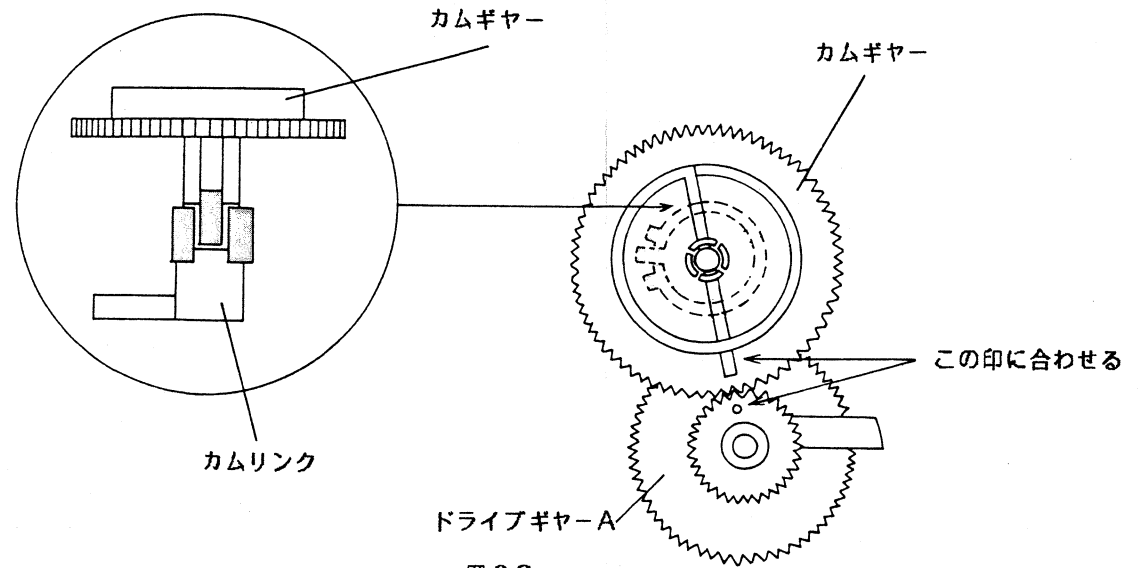

図30

Wiring Diagram

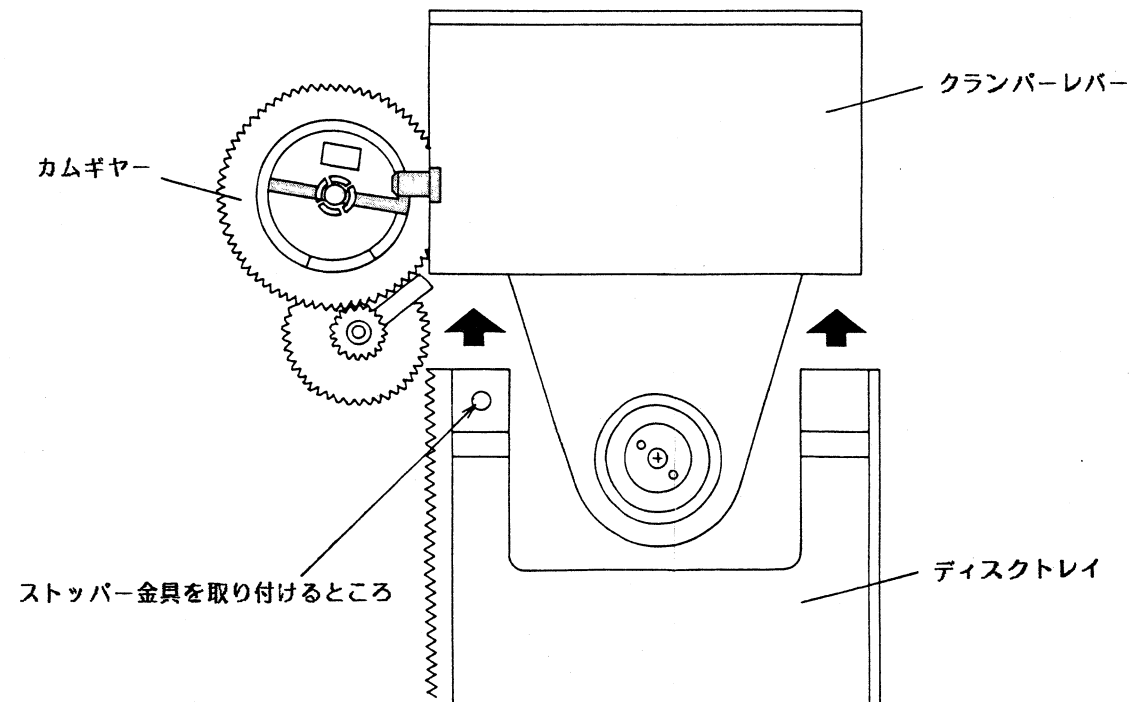
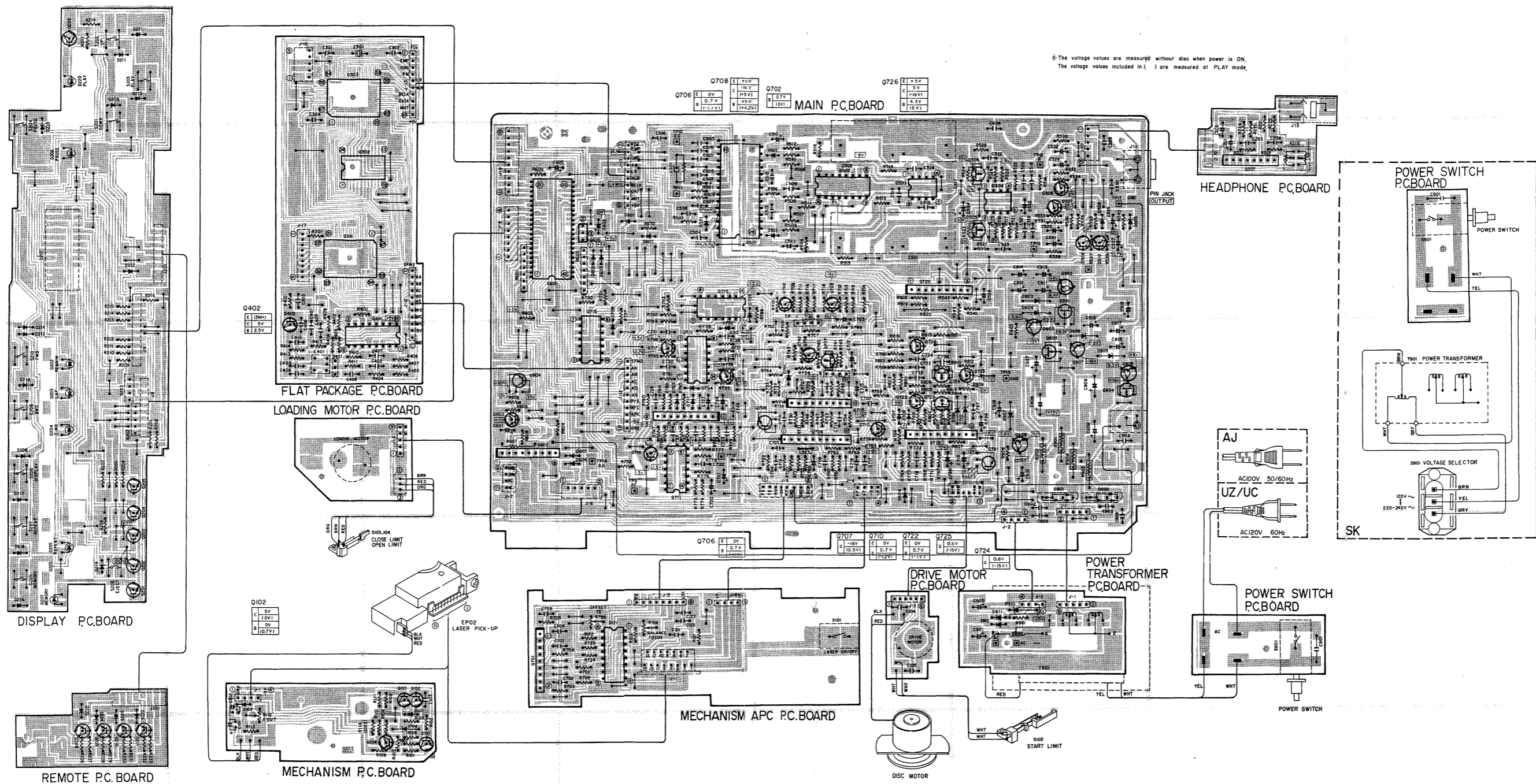

*The voltage values are measured without disc when power is ON.
 The voltage values included in () are measured at PLAY mode.

Schematic Diagram

* The voltage values are measured without disc when power is ON.
 The voltage values included in () are measured at PLAY mode.

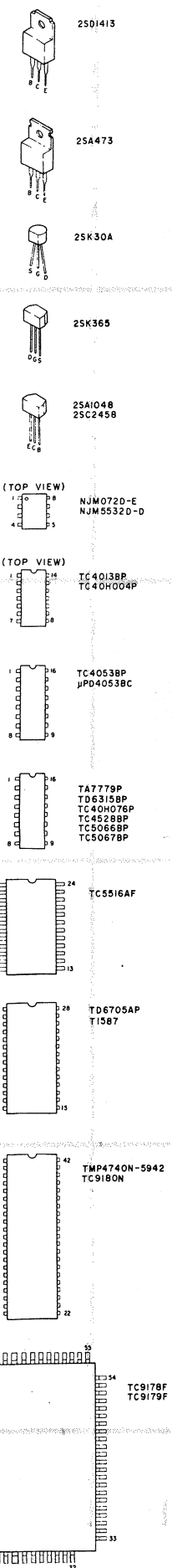
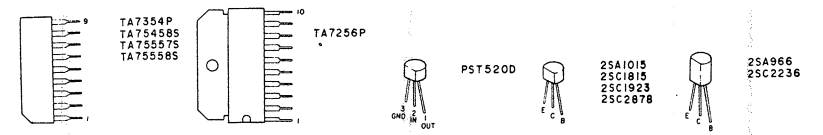
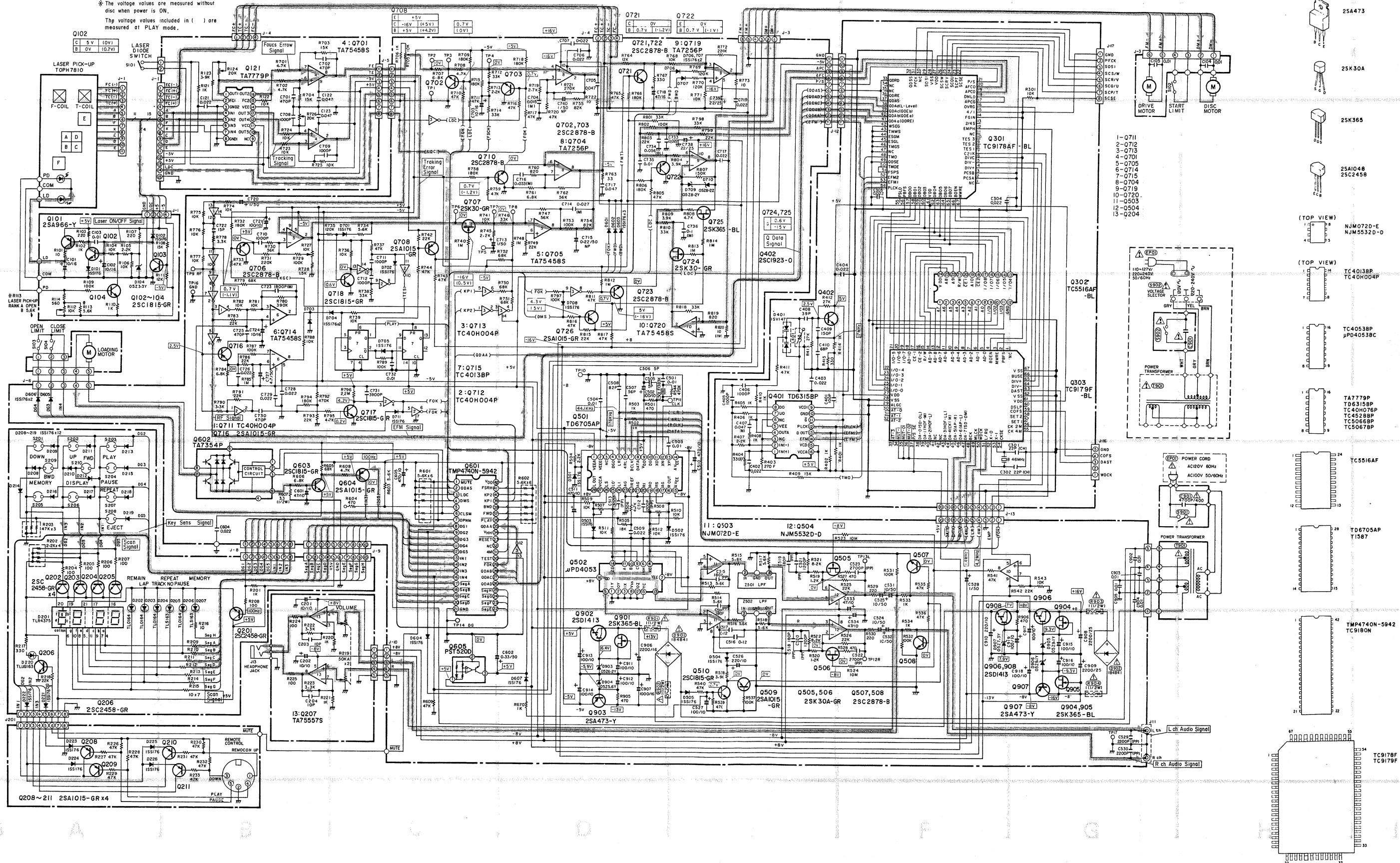

Parts List

CAUTION:

The Δ mark, the symbol No. circled with oval in the schematic diagram and the shaded area in the parts list designate components which have special characteristics important for safety and should be replaced only with types identical to those in the original circuit or specified in the parts list.

Symbol No.	Part No.	Description
TRANSISTORS, IC'S & DIODES		
Q101	36533240	Transistor, 2SA966-Y
Q102, 103, Q104	36317460	Transistor, 2SC1815NEW-GR
Q121	40358290	IC, TA7779P
Q201, 202, Q203, 204, Q205, 206	36332440	Transistor, 2SC2458-GR
Q207	40350410	IC, TA75557S
Q208, 209, Q210, 211	36534060	Transistor, 2SA1015-GR
Q401	40272167	IC, TD63158P
Q402	36319020	Transistor, 2SC1923-O
Q501	40272705	IC, TD6705AP
Q502	22117199	IC, μ PD4053BC
Q503	22117053	IC, NJM072D-E
Q504	22117637	IC, NJM5532D-D
Q505, 506	36048370	Transistor, 2SK30ATM-GR
Q507, 508	36342210	Transistor, 2SC2878-B
Q509	36534060	Transistor, 2SA1015-GR
Q510	36317460	Transistor, 2SC1815NEW-GR
Q601	40406697	IC, TMP4740N-5942
Q602	40325460	IC, TA7354P
Q603	36317460	Transistor, 2SC1815NEW-GR
Q604	36534060	Transistor, 2SA1015-GR
Q605	22117550	IC, PST520D
Q701	40350010	IC, TA75458S
Q702, 703	36342210	Transistor, 2SC2878-B
Q704	40320320	IC, TA7256P
Q705	40350010	IC, TA75458S
Q706	36342210	Transistor, 2SC2878-B
Q707	36048370	Transistor, 2SK30ATM-GR
Q708	36534060	Transistor, 2SA1015-GR
Q710	36342210	Transistor, 2SC2878-B
Q711, 712, Q713	40471040	IC, TC40H004P
Q714	40350010	IC, TA75458S
Q715	40470045	IC, TC4013BP
Q716	36534060	Transistor, 2SA1015-GR
Q717, 718	36317460	Transistor, 2SC1815NEW-GR
Q719	40320320	IC, TA7256P
Q720	40350010	IC, TA75458S
Q721, 722, Q723	36342210	Transistor, 2SC2878-B

Symbol No.	Part No.	Description
Q724	36048370	Transistor, 2SK30ATM-GR
Q725	36058730	Transistor, 2SK365-BL
Q726	36534060	Transistor, 2SA1015-GR
Q901	36058730	Transistor, 2SK365-BL
Q902	36868350	Transistor, 2SD1413
Q903	36500740	Transistor, 2SA473-Y
Q904, 905	36058730	Transistor, 2SK365-BL
Q906	36868350	Transistor, 2SD1413
Q907	36500740	Transistor, 2SA473-Y
Q908	36868350	Transistor, 2SD1413
D101, 102	37160570	Diode, 1SS176
D104	37109333	Diode, 05Z3.3-Y, Zener
D201	38632620	Display Diode, TLR4375
D202, 203, D204	38612210	Diode, TLO164
D205	38636560	Diode, TLS163
D206	38612210	Diode, TLD164
D207	38636560	Diode, TLS163
D208, 209, D210, 211, D212, 213, D214, 215, D216, 217, D218, 219	37160571	Diode, 1SS176
D220	38690640	Diode, TLUG163
D221, 222, D223, 224, D225, 226	37160571	Diode, 1SS176 (TPA4)
D401	37288890	Diode, 1SV147, Variable Cap.
D501, 502, D503, 504, D505	37160570	Diode, 1SS176
D601, 602, D603, 604, D605, 606	37160570	Diode, 1SS176
D701, 702, D703, 704, D705, 706, D707, 708	37160570	Diode, 1SS176
D709	37110208	Diode, 05Z8.2-Y, Zener
D710	37110209	Diode, 05Z8.2-Z, Zener
D711	37160570	Diode, 1SS176

Symbol No.	Part No.	Description
Δ D901, 902	37670800	Diode, 1B4B41
D903	37110076	Diode, 05Z6.2-Y, Zener
D904	37110017	Diode, 05Z5.6-Y, Zener
D905, 906	37110262	Diode, 05Z9.1-Y, Zener
D907	37110160	Diode, 05Z7.5-Y, Zener
ELECTRICAL PARTS		
L401	22245445	Coil, PLL
L501	35613051	Coil, F1383K
Δ T901	22224452	Power Transformer (JA)
Δ T901	22224487	Power Transformer (UC, UQ)
Δ T901	22224530	Power Transformer (AD)
S101	22196637	Leaf Switch, Laser ON/OFF
S102	22196597	Leaf Switch, Start Limit
S103, 104	22196598	Leaf Switch, Open/Close
S201, 202	22196228	Key Switch, Down/Up
S203	22196228	Key Switch, Play
S204	22196228	Key Switch, Pause
S205, 206, S207	22196228	Key Switch, Memory
S208	22196228	Key Switch, Eject
S209	22196228	Key Switch, Backward
S210	22196228	Key Switch, Forward
Δ S901	22196362	Push Switch, Power
Δ S902	22184238	Voltage Selector
J11	22198012	Pin Jack, 2P, Output
J13	22198165	Jack, 6D, Headphone
Z301	22153355	Lithium Oscillator, 8.4672 MHz
Z501, 502	22137770	Low-pass Filter Ass'y
Δ EP01	22176712	Power Cord (JA)
Δ EP01	22176574	Power Cord (UC, UQ)
Δ EP01	22176616	Power Cord (AD)
EP02	35801010	Laser Pick-up, TOPH810
EP03	22192743	Flat Package P.C. Board Ass'y with TC9178AF-BL, TC5516AF, TC9179F-BL, TD6315BP, 2SC1923-O, Others

Symbol No.	Part No.	Description
CAPACITORS		
J = $\pm 5\%$, K = $\pm 10\%$, M = $\pm 20\%$, P = $-20+100\%$, Z = $-20+80\%$, NP = Non Polarity		
ABBREVIATIONS: EL = Electrolytic, CD = Ceramic Disk, BL = Barrier Layer, PP = Polypropylene		
C101, 102	22440444	EL, 10mfd, 16V
C103, 104	22342103	CD, 0.01mfd, 50V, Z
C105	22342103	CD, 0.01mfd, 50V, Z
C106	22483101	EL, 100mfd, 10V
C121	22342223	CD, 0.022mfd, 50V, Z
C122, 123	22360331	BL, 0.047mfd, 25V, M
C201, 202	22488100	EL, 10mfd, 50V
C203, 204	22361100	CD, 10pF, 50V, J
C301, 302	22360134	CD, 22pF, 50V, J, CH
C303, 304	22342223	CD, 0.022mfd, 50V, Z
C401	22362101	CD, 100pF, 50V, K
C402, 403	22342223	CD, 0.022mfd, 50V, Z
C404	22342223	CD, 0.022mfd, 50V, Z
C405, 406	22349102	CD, 1000pF, 50V, K
C407	22372473	MY, 0.047mfd, 50V, K
C408	22362390	CD, 39pF, 50V, K
C409	22362151	CD, 150pF, 50V, K
C410	22362680	CD, 68pF, 50V, K
C501	22342103	CD, 0.01mfd, 50V, Z
C502	22483101	EL, 100mfd, 10V
C503, 504	22342103	CD, 0.01mfd, 50V, Z
C505, 506	22361509	CD, 5pF, 50V
C507	22362560	CD, 56pF, 50V, K
C508	22362820	CD, 82pF, 50V, K
C509	22342223	CD, 0.022mfd, 50V, Z
C510, 511	22483471	EL, 470mfd, 10V
C512, 513	22321058	PP, 1200pF, 50V, J
C514, 515	22321084	PP, 180pF, 50V, J
C516, 517	22370322	Micro Film, 0.12mfd, 50V, J
C518, 519	22321084	PP, 180pF, 50V, J
C520, 521	22321058	PP, 1200pF, 50V, J
C522, 523	22321062	PP, 2700pF, 50V, J
C524, 525	22440751	EL, 10mfd, 50V
C526	22483221	EL, 220mfd, 10V
C527	22483101	EL, 100mfd, 10V
C528	22488109	EL, 1mfd, 50V
C529, 530	22321061	PP, 2200pF, 50V, J
C531, 532	22440751	EL, 10mfd, 50V
C533, 534	22483470	EL, 47mfd, 10V
C601	22483470	EL, 47mfd, 10V
C602	22488338	EL, 0.33mfd, 50V
C603	22342223	CD, 0.022mfd, 50V, Z
C604	22342223	CD, 0.022mfd, 50V, Z
C605	22483471	EL, 470mfd, 10V

Symbol No.	Part No.	Description
C701, 702	22349471	CD, 470pF, 50V, K
C703	22485100	EL, 10mfd, 16V, M
C704	22371153	MY, 0.015mfd, 50V, K
C705	22360484	CD, 0.047mfd, 50V, Z
C706	22342223	CD, 0.022mfd, 50V, Z
C707	22342223	CD, 0.022mfd, 50V, Z
C708, 709	22349102	CD, 1000pF, 50V, K
C710, 711	22349102	CD, 1000pF, 50V, K
C712	22349102	CD, 1000pF, 50V, K
C713	22488109	EL, 1mfd, 50V
C714	22371273	MY, 0.027mfd, 50V, J
C715	22478228	EL, 0.22mfd, 50V, NP
C716	22371333	MY, 0.033mfd, 50V, J
C717	22360484	CD, 0.047mfd, 50V, Z
C718	22485470	EL, 47mfd, 16V
C719	22342223	CD, 0.022mfd, 50V, Z
C720	22488109	EL, 1mfd, 50V
C721	22483101	EL, 100mfd, 10V
C722	22362150	CD, 15pF, 50V, K
C723	22371182	MY, 1800pF, 50V, J
C724	22485100	EL, 10mfd, 16V
C725	22349471	CD, 470pF, 50V, K
C726	22342223	CD, 0.022mfd, 50V, Z
C727	22488479	EL, 4.7mfd, 50V
C728, 729	22342223	CD, 0.022mfd, 50V, Z
C730	22349471	CD, 470pF, 50V, K
C731	22349392	CD, 3900pF, 50V, K
C732	22349103	CD, 0.01mfd, 50V, K
C733	22342223	CD, 0.022mfd, 50V, Z
C734	22360553	BL, 0.056mfd, 25V, K
C735	22342103	CD, 0.01mfd, 50V, Z
C736	22371104	MY, 0.1mfd, 50V, J
C737	22342223	CD, 0.022mfd, 50V, Z
C738, 739	22486220	EL, 22mfd, 25V
C740	22478109	EL, 1mfd, 50V, NP
△ C901	22340167	CD, 4700pF, 400V, P (AJ)
△ C901	22340226	CD, 4700pF, 400V, M (UZ, UC, AK)
C902, 903	22342103	CD, 0.01mfd, 50V, Z
C904, 905	22342103	CD, 0.01mfd, 50V, Z
C906	22485222	EL, 2200mfd, 16V
C907	22485102	EL, 1000mfd, 16V
C908, 909	22486222	EL, 2200mfd, 25V
C910	22483221	EL, 220mfd, 10V
C911, 912	22483101	EL, 100mfd, 10V
C913, 914	22483101	EL, 100mfd, 10V
C915, 916	22483101	EL, 100mfd, 10V
C917, 918	22483101	EL, 100mfd, 10V
C919	22483101	LE, 100mfd, 10V

Symbol No.	Part No.	Description
RESISTORS		
All resistors are carbon film, 1/6W, ±5% unless otherwise noted. 1K ohm = 1000 ohm, 1M ohm = 1000000 ohm		
R101	22584100	10 ohm
R102	22584102	1K ohm
R103	22584221	220 ohm
R104	22584103	10K ohm
R105	22584222	2.2K ohm
R106	22586103	10K ohm
R107	22584221	220 ohm
R108	22584153	15K ohm
R109	22584104	100K ohm
R110	22584102	1K ohm
R111	22584123	12K ohm
R112	22658761	10K ohm, Semi-fixed Variable
R113	22584562	5.6K ohm
R114	22584561	560 ohm
R121	22584102	1K ohm
R122	22584103	10K ohm
R123	22584392	3.9K ohm
R124	22658827	20K ohm, Semi-fixed Variable
R201	22584102	1K ohm
R202	22540776	5.6K ohm x 4, Composite Part
R203	22540777	47K ohm x 3, Composite Part
R204, 205, R206, 207, R208	22584101	100 ohm
R209, 210, R211, 212, R213, 214, R215	22584100	10 ohm
R217	22584331	330 ohm
R218	22584223	22K ohm
R219	22611413	Volume, VR09-503A 50K ohm, A
R220, 221	22584102	1K ohm
R222, 223	22584332	3.3K ohm
R224, 225	22584101	100 ohm
R226, 227, R228, 229, R230, 231, R226, 227, R228, 229, R230, 231, R232, 233	22584473	47K ohm
R301	22584103	10K ohm

Symbol No.	Part No.	Description
R401, 402	22584102	1K ohm
R403	22570693	270 ohm, 1/4W, ±1%, Metal Film
R404	22570694	330 ohm, 1/4W, ±1%, Metal Film
R405, 406	22584102	1K ohm
R407	22584222	2.2K ohm
R408	22584102	1K ohm
R409	22584153	15K ohm
R410	22584102	1K ohm
R411	22584473	47K ohm
R412, 413	22584273	27K ohm
R414	22584102	1K ohm
R415	22584331	330 ohm
R501	22584471	470 ohm
R502, 503	22584102	1K ohm
R504	22584222	2.2K ohm
R505	22584183	18K ohm
R506	22584472	4.7K ohm
R507, 508	22658826	10K ohm, Semi-fixed Variable
R509, 510	22584103	10K ohm
R511, 512	22584103	10K ohm
R513, 514	22584562	5.6K ohm
R515, 516	22584562	5.6K ohm
R517, 518	22584562	5.6K ohm
R519, 520	22584122	1.2K ohm
R521, 522	22584822	8.2K ohm
R523, 524	22555106	10M ohm, 1/4W
R525, 526	22584223	22K ohm
R527, 528	22584471	470 ohm
R529, 530	22584221	220 ohm
R531, 532	22584104	100K ohm
R533, 534	22584102	1K ohm
R535, 536	22584473	47K ohm
R537	22584104	100K ohm
R538	22584392	3.9K ohm
R539, 540	22584473	47K ohm
R541	22584473	47K ohm
R542	22584223	22K ohm
R543	22584103	10K ohm
R544	22584474	470K ohm
R601, 602	22540781	5.6K ohm x 6, Composite Part
R603	22584562	5.6K ohm
R604	22584471	470 ohm
R605	22584683	68K ohm
R606	22584682	6.8K ohm
R607	22547339	3.3 ohm, 1/2W
R608	22584472	4.7K ohm
R609	22584473	47K ohm
R670	22584102	1K ohm

Symbol No.	Part No.	Description
R701, 702	22584472	4.7K ohm
R703, 704	22584153	15K ohm
R705	22658826	10K ohm, Semi-fixed Variable
R706	22584102	1K ohm
R707	22584682	6.8K ohm
R708	22584472	4.7K ohm
R709	22584184	180K ohm
R710, 711	22584473	47K ohm
R712	22584333	33K ohm
R713	22584222	2.2K ohm
R715	22584333	33K ohm
R715	22584184	180K ohm
R716, 717	22584473	47K ohm
R718	22584184	180K ohm
R719	22584272	2.7K ohm
R720	22584473	47K ohm
R721	22584274	270K ohm
R722	22584100	10 ohm
R723, 724	22584103	10K ohm
R725	22584103	10K ohm
R726	22658827	20K ohm, Semi-fixed Variable
R727	22658826	10K ohm, Semi-fixed Variable
R728	22584152	1.5K ohm
R729	22584104	100K ohm
R730	22584563	56K ohm
R731	22584224	220K ohm
R732	22584184	180K ohm
R733	22584473	47K ohm
R734	22584562	5.6K ohm
R735	22584124	120K ohm
R736	22584103	10K ohm
R737	22584473	47K ohm
R738	22584333	33K ohm
R739	22584103	10K ohm
R740	22584105	1M ohm
R741	22584103	10K ohm
R742	22584223	22K ohm
R743, 744	22584473	47K ohm
R745	22584222	2.2K ohm
R746	22584333	33K ohm
R747	22584563	56K ohm
R748	22584105	1M ohm
R749	22584223	22K ohm
R750, 751	22584683	68K ohm
R752	22584683	68K ohm
R753	22584104	100K ohm
R754, 755	22584823	82K ohm
R758	22584184	180K ohm
R759	22584473	47K ohm

Symbol No.	Part No.	Description
R760	22584821	820 ohm
R761	22584682	6.8K ohm
R762	22584563	56K ohm
R763	22584330	33 ohm
R764	22584123	12K ohm
R765	22584473	47K ohm
R766	22584184	180K ohm
R767	22584331	330 ohm
R768	22584103	10K ohm
R769, 770	22584124	120K ohm
R771	22584103	10K ohm
R772	22584224	220K ohm
R773	22584100	10 ohm
R774, 775	22584103	10K ohm
R776, 777	22584103	10K ohm
R778	22584332	3.3K ohm
R779	22584683	68K ohm
R780	22584394	390K ohm
R781, 782	22584103	10K ohm
R783	22584223	22K ohm
R784	22584682	6.8K ohm
R785	22584105	1M ohm
R786	22584223	22K ohm
R787	22584104	100K ohm
R788	22584103	10K ohm
R789	22584104	100K ohm
R790	22584332	3.3K ohm
R791	22584223	22K ohm
R792	22584474	470K ohm
R793	22584223	22K ohm
R794	22584184	180K ohm
R795	22584472	4.7K ohm
R796	22584225	2.2M ohm
R797	22584104	100K ohm
R798	22584333	33K ohm
R799	22584223	22K ohm
R801	22584333	33K ohm
R802	22584104	100K ohm
R803	22584223	22K ohm
R804	22584392	3.9K ohm
R805	22584473	47K ohm
R806	22584184	180K ohm
R807	22584154	150K ohm
R808	22584472	4.7K ohm
R809	22584392	3.9K ohm
R810	22584333	33K ohm
R811	22584473	47K ohm
R812, 813	22584105	1M ohm
R814	22584105	1M ohm
R815	22584223	22K ohm
R816, 817	22584473	47K ohm

Symbol No.	Part No.	Description
R818	22584333	33K ohm
R819	22584821	820 ohm
R820	22570432	10 ohm, 1W, Metal Oxide Film
△ R901, 902	22500201	1 ohm, 1/2W, Fusible
△ R903, 904	22500201	1 ohm, 1/2W, Fusible
R905, 906	22584471	470 ohm
ACCESSORIES		
AC01	68P70001F35	Owner's Manual (JA)
AC01	68P70001F46	Owner's Manual, BLK (UQ, AD)
AC01	68P67499F81	Owner's Manual, Silver (UC)
AC01	68P70001F45	Owner's Manual, Silver (UQ, AD)
AC02	22164775	Plug, Radio Cable
AC03	22922576	Carton, Packing D-103 (UQ, AD)
AC03	22922577	Carton, Packing D-404 (UQ, AD, UC)
AC03	22922575	Carton, Packing D-103 (JA)
AC04	22936144	Cushion (L)
AC05	22936145	Cushion (R)

Mechanism Exploded View

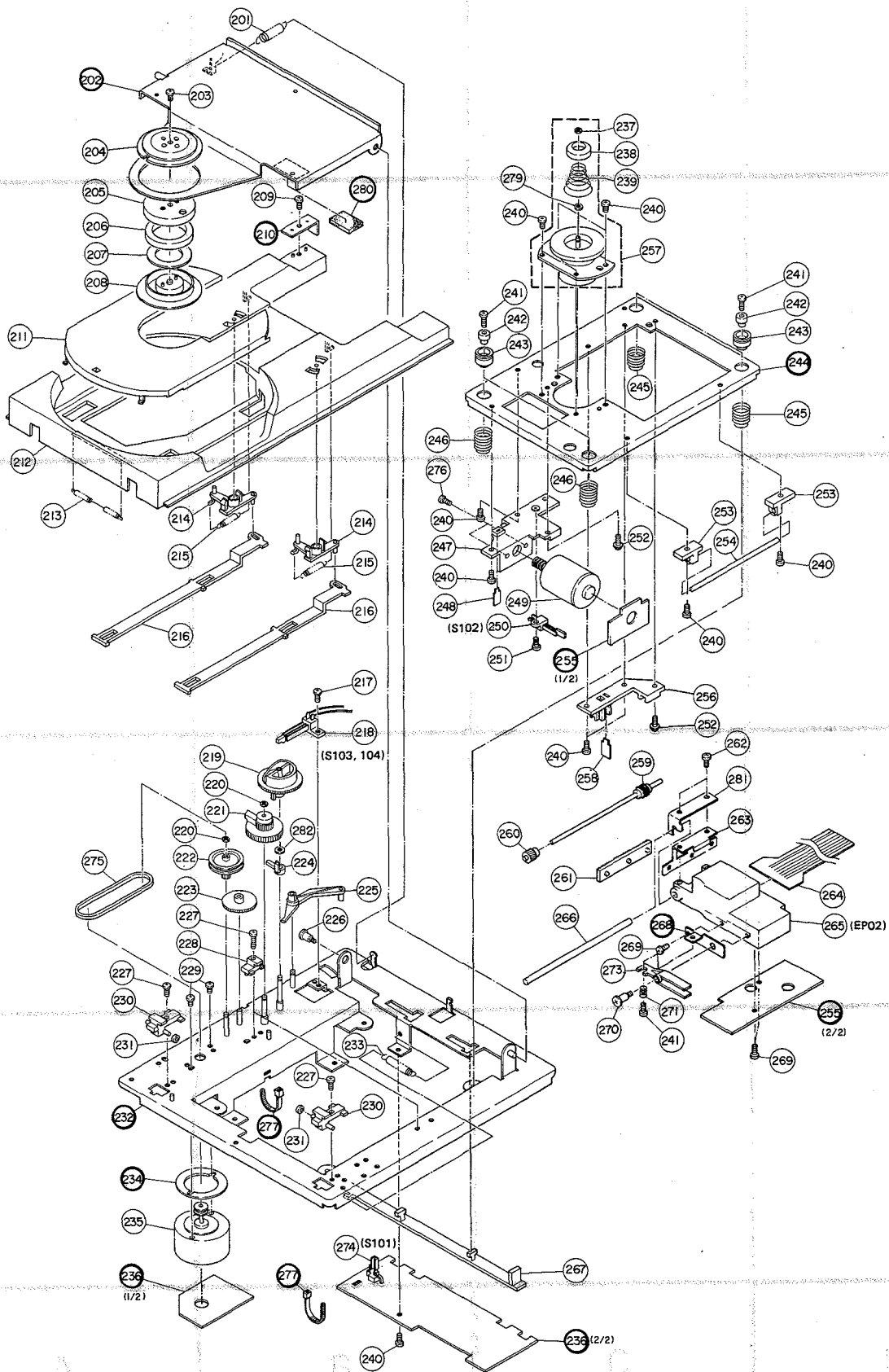

Mechanism Assembly Parts List

Symbol No.	Part No.	Description	Symbol No.	Part No.	Description
201	25776891	Spring	252	22708405	Screw, $\phi 2.6 \times 10\text{mm}$
203	22701311	Screw, $\phi 2 \times 5\text{mm}$, BID Tapping	253	20776143	Shaft Holder B
204	20754201	Clamper Plate	254	20764260	Guide Shaft B
205	20748088	Clamper Yoke	256	20776142	Shaft Holder A
206	20754089	Magnet	257	28775002	Disc Motor Ass'y
207	20748257	Magnet Spacer	258	25779512	Spring, Drive
208	20754091	Clamper	259	25791905	Drive Shaft Ass'y
209	22707913	Screw, $\phi 2.6 \times 6\text{mm}$, BID Tapping	260	20727130	Gear, WH
211	20778191	Sub Tray	261	20727127	Rack Gear
212	20778190	Disc Tray	262	22701467	Screw, $\phi 2 \times 3\text{mm}$, BID
213	25776854	Spring	263	25779510	Spring, Rack
214	20754218	Tray Lever	264	22192633	Flexible P.C. Board
215	25776855	Spring	265 (EP02)	35801010	Laser Pick-up, TOPH7810
216	20754220	Tray Slider	266	20764197	Guide Shaft A
217	22707366	Screw, $\phi 2.6 \times 6\text{mm}$, BID	267	20754216	Lift Slider
218 (S103, 104)	22196598	Leaf Switch	269	22707494	Screw, $\phi 2.6 \times 4\text{mm}$, BID
219	20727134	Cam Gear	270	22708271	Holder Screw
220	20776135	Washer, $\phi 2.1$	271	25777425	Spring, Pick-up
221	20727135	Drive Gear	273	20754207	Guide Lever
222	20727083	Drive Gear A	274 (S101)	22196637	Leaf Switch
223	20727125	Loading Gear B	275	25759027	Drive Belt
224	20757038	Cam Link	276	22707265	Screw, $\phi 2 \times 4\text{mm}$, BID
225	20754217	Lift Lever	279	25764392	Washer, $\phi 1.9$
226	22701472	Screw, $\phi 2.6 \times 13\text{mm}$, FLT	281	20743175	Spring Plate, Rack
227	22707368	Screw, $\phi 2.6 \times 10\text{mm}$, BID	282	20776148	Washer, $\phi 3.2$
228	20748246	Tray Guide			
229	22701389	Screw, $\phi 2.6 \times 3\text{mm}$, BID			
230	20748223	Roller Mount			
231	20727119	Roller			
233	25776669	Spring			
235	28775049	Loading Motor Ass'y			
237	25764549	Washer, $\phi 1.7$			
238	20723146	Center Ring			
239	25777270	Clamper Spring			
240	22707350	Screw, $\phi 2.6 \times 5\text{mm}$, BID			
241	22707367	Screw, $\phi 2.6 \times 8\text{mm}$, BID			
242	22708378	Spacer A			
243	25761530	Cushion			
245	25777426	Spring, A			
246	25777427	Spring, B			
247	20748230	Motor Mount			
248	25779511	Spring, Motor			
249	28775005	Drive Motor Ass'y			
250 (S102)	22196597	Leaf Switch			
251	22708040	Screw, $\phi 2 \times 5\text{mm}$, BID Tapping			

Exploded View (Cabinet)

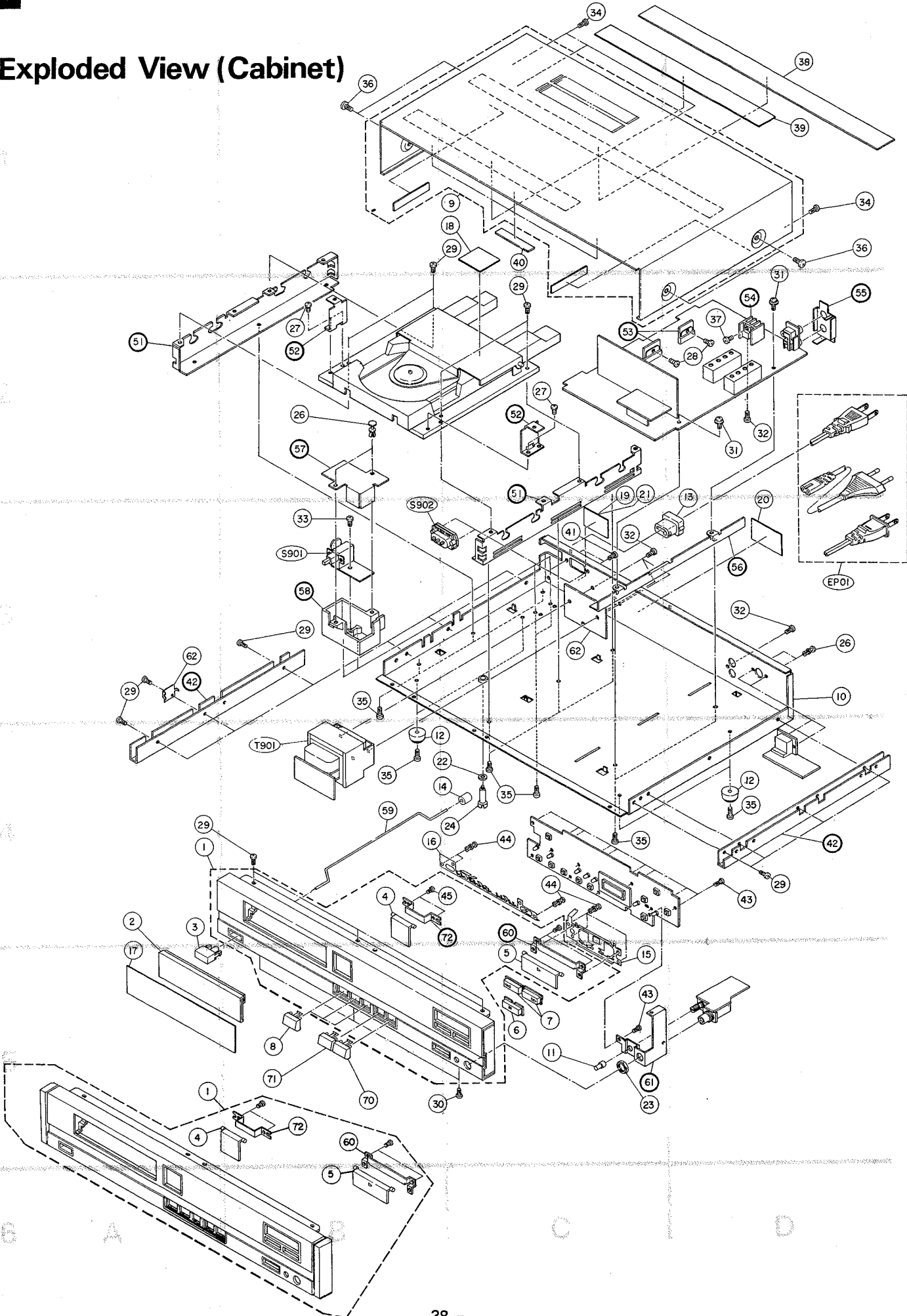

Cabinet Assembly Parts List

CAUTION:

The  mark, the symbol No. circled with oval in the schematic diagram and the shaded area in the parts list designate components which have special characteristics important for safety and should be replaced only with types identical to those in the original circuit or specified in the parts list.

Symbol No.	Part No.	Description	Symbol No.	Part No.	Description
1	20017295	Front Panel Ass'y BLK (JA)	14	22764307	Joint Knob
1	20017296	Front Panel Ass'y, Silver (UC, UQ, AD)	15	25779573	Plate, Earth-A
1	20017299	Front Panel Ass'y, BLK (UQ, AD)	16	25779574	Plate, Earth-B
2	20017297	Tray Panel Ass'y, BLK (JA, UQ, AD)	17	22907122	Caution Label, Screw (JA)
2	20017298	Tray Panel Ass'y, Silver (UC, UQ, AD)	17	22907123	Caution Label, Screw (UQ, AD)
3	20872160	Knob, Power, BLK (JA, UQ, AD)	17	22907124	Caution Label, Screw (UC)
3	20872168	Knob, Power, Silver (UC, UQ, AD)	18	22907058	Caution Label, Laser-3
4	20872156	Knob, Eject, BLK (JA, UQ, AD)	19	22900504	Caution Label, Laser-85 (UC)
4	20872164	Knob, Eject, Silver (UC, UQ, AD)	20	22907068	Caution Label, CD (UQ)
5	20872153	Knob, Play, BLK (JA, UQ, AD)	21	22906500	Caution Label, Class-1 (AD)
5	20872161	Knob, Play, Silver (UC, UQ, AD)	22	22703437	Washer, $\phi 5.5$
6	20872154	Knob, Pause, BLK (JA, UQ, AD)	23	22702198	Nut, M12
6	20872162	Knob, Pause, Silver (UC, UQ, AD)	24	22708471	Pick-up Screw
7	20872155	Knob, Up/Down, BLK (JA, UQ, AD)	25	22705021	Plastic Rivet, $\phi 3 \times 3.5\text{mm}$
7	20872163	Knob, Up/Down, Silver (UC, UQ, AD)	26	22705020	Plastic Rivet, $\phi 3 \times 4.5\text{mm}$
8	20872157	Knob, Memory, BLK (JA, UQ, AD)	27	22707494	Screw, $\phi 2.6 \times 4\text{mm}$, DTBID
8	20872165	Knob, Memory, Silver (UC, UQ, AD)	28	22707445	Screw, $\phi 3 \times 6\text{mm}$, DTBID
9	20823113	Top Cover, BLK (JA, UQ, AD)	29	22707910	Screw, $\phi 3 \times 6\text{mm}$, BID Tapping
9	20823114	Top Cover, Silver (UC, UQ, AD)	30	22707942	Screw, $\phi 3 \times 6\text{mm}$, BID Tapping, BLK
10	20013062	Chassis, BLK (JA)	30	22708117	Screw, $\phi 3 \times 6\text{mm}$, BID Tapping, Chrome
10	20013063	Chassis, Silver (UC, UQ)	31	22708022	Screw, $\phi 3 \times 6\text{mm}$, Tapping, RED
10	20013064	Chassis, Silver (AD)	32	22708118	Screw, $\phi 3 \times 8\text{mm}$, BID Tapping, Chrome
10	20013065	Chassis, BLK (AD)	33	22702202	Screw, $\phi 3 \times 8\text{mm}$, BID Tapping, RED
10	20013067	Chassis, BLK (UQ)	34	22707911	Screw, $\phi 3 \times 8\text{mm}$, BID Tapping, BLK
11	22884487	Knob, Volume, BLK (JA, UQ, AD)	34	22708118	Screw, $\phi 3 \times 8\text{mm}$, BID Tapping, Chrome
11	22884587	Knob, Volume, Silver (UC, UQ, AD)	35	22707842	Screw, $\phi 3 \times 8\text{mm}$, BID Tapping
12	22874033	Foot	36	22708332	Screw, $\phi 4 \times 6\text{mm}$, DTBID, Silver
	25844322	Cord Bush	36	22707185	Screw, $\phi 4 \times 8\text{mm}$, FTBID, BLK
			37	22707520	Screw, $\phi 3 \times 8\text{mm}$, DTBID
			38	22766097	Cover, Tape
			39	22766183	Cover, Tape
			40	20849404	Felt
			41	22707364	Screw, $\phi 3 \times 4\text{mm}$, BID
			42	※	Support Side (JA)
			43	22708265	Screw, $\phi 2.6 \times 8\text{mm}$, DTBID

Note: ※ The parts without part numbers are not supplied.

Symbol No.	Part No.	Description
44	22705050	Plastic Rivet, ϕ 2.6 x 3.2mm
45	22707979	Screw, ϕ 2.6 x 8mm, DTBID
57	※	Cover, Power
58	※	Case, Power
59	22764354	Push Rod, Power
60	※	Bracket, Play
62	20024217	Bracket, Rod
70	20872158	Knob, FF, BLK (JA, UQ, AD)
70	20872166	Key, Switch FF, Silver (UC, UQ, AD)
71	20872159	Knob, REW, BLK (JA, UQ, AD)
71	20872167	Key, Switch REW, Silver (UC, UQ, AD)
72	※	Bracket Eject

Symbol No.	Part No.	Description

Note: ※ The parts without part numbers are not supplied.

IC	Q121		Q714		Q701		Q715		Q601		Q704	
Transistor (Q)	Q101 Q102 Q104 Q103		Q716 Q706		Q207 Q718 Q717		Q712 Q708 Q702		Q605 Q707 Q710		Q703	
Diode (D)	D216 D217 D222 D220 D221 D223 D224		D101 D104 D102 D213 D215 D218 D219 D202 ~ D207 D225 D226		D703 D704		D702 D705 D711		D604		D607 D708	

* The voltage values are measured without disc when power is ON.
The voltage values included in () are measured at PLAY mode.

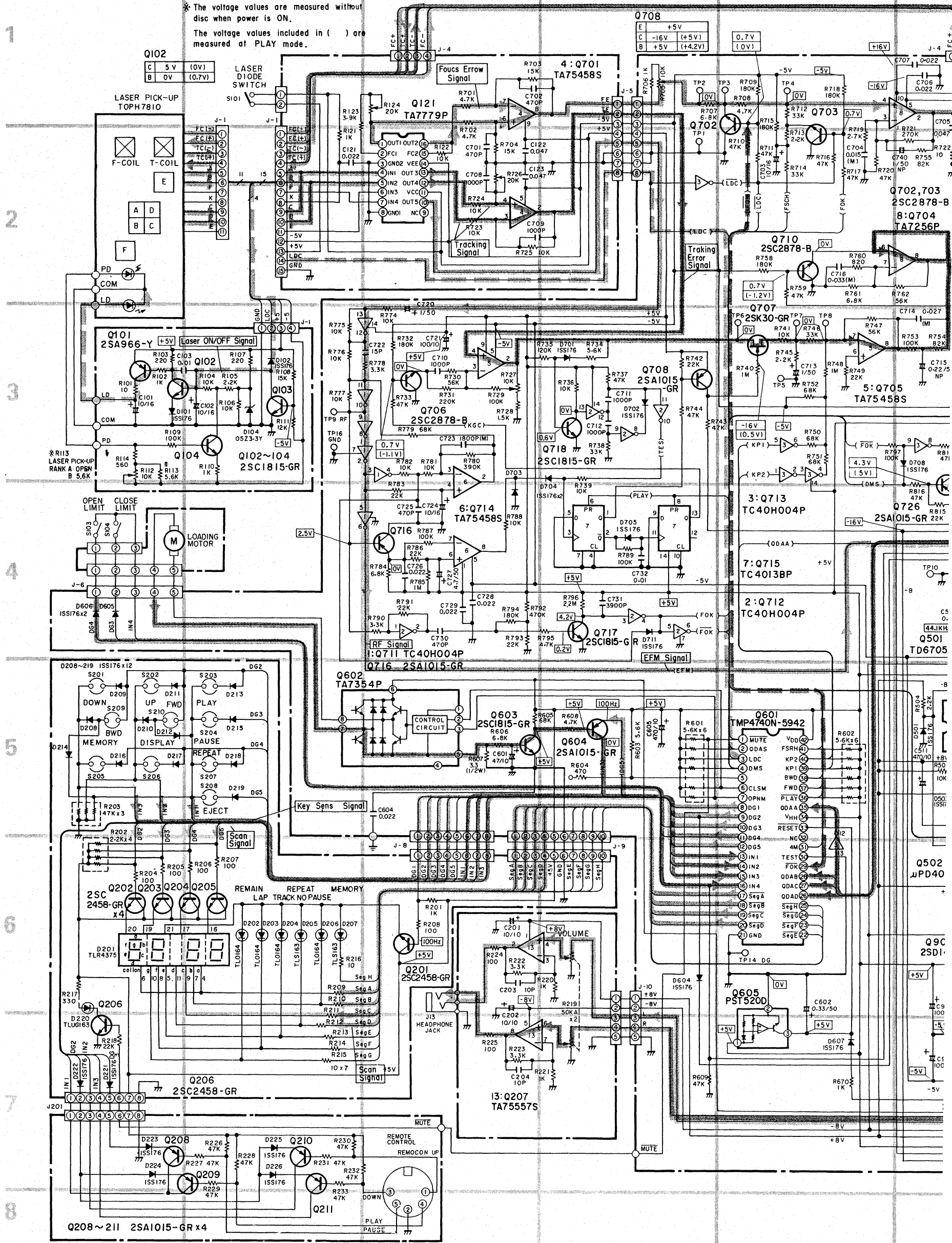

Q704 Q719 Q501 Q720 Q503 Q401 Q504 Q301 Q303 Q302
 Q721 Q722 Q724 Q725 Q402 Q505 Q507 Q908 Q906 Q904
 Q723 Q902 Q901 Q903 Q510 Q509 Q506 Q508 Q907 Q905 Q905
 D708 D601,D602,D603 D502 D706 D707 D907 D905 D906 D902
 D501 D503 D903,D904 D901 D505 D709 D710 D504

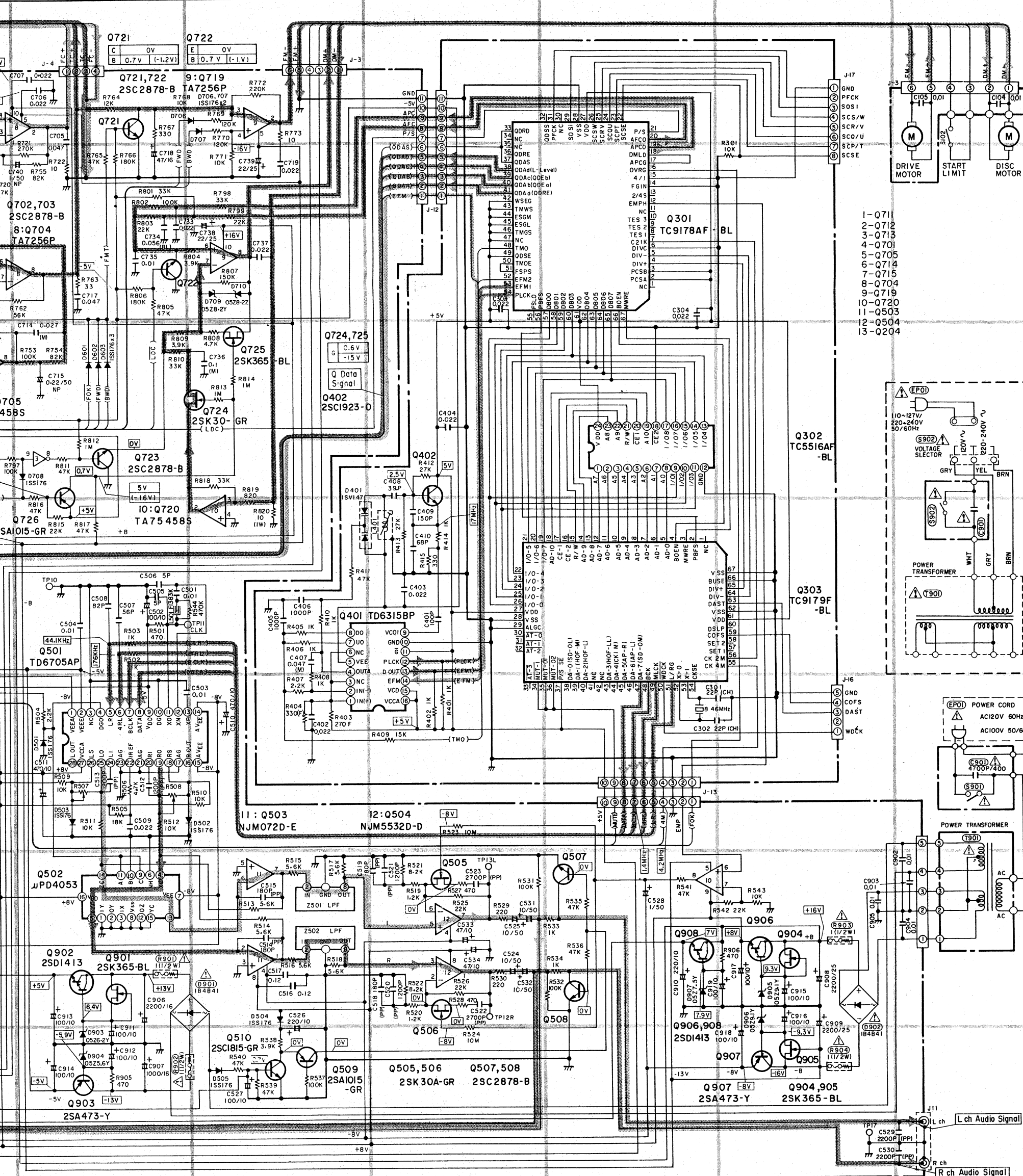

- 1-Q711
- 2-Q712
- 3-Q713
- 4-Q701
- 5-Q705
- 6-Q714
- 7-Q715
- 8-Q704
- 9-Q719
- 10-Q720
- 11-Q503
- 12-Q504
- 13-Q204

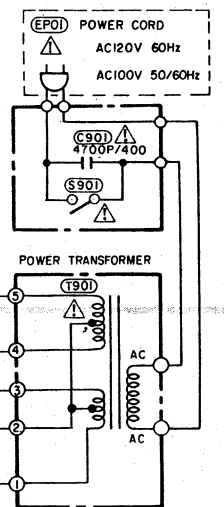
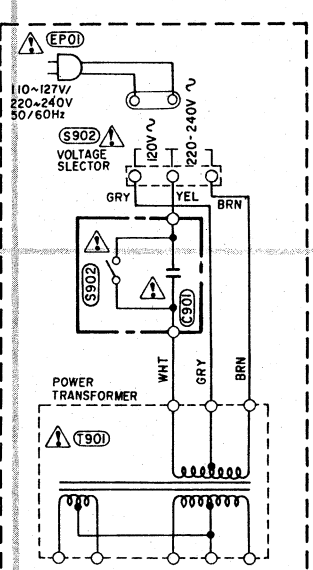

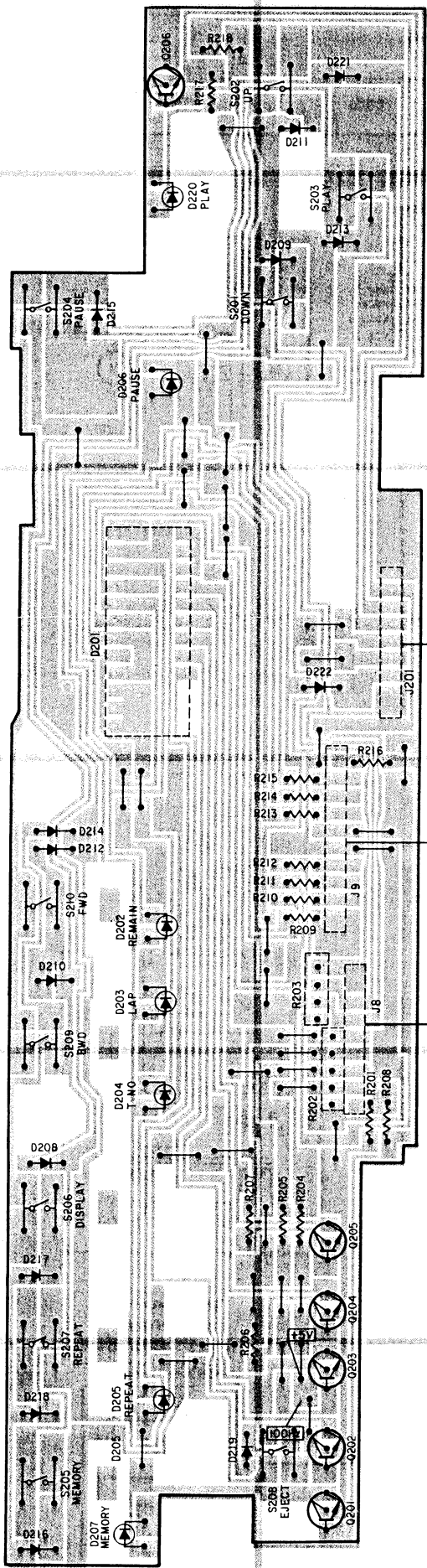

DISPLAY P.C. BOARD

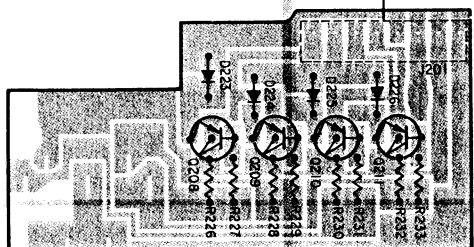

REMOTE P.C. BOARD

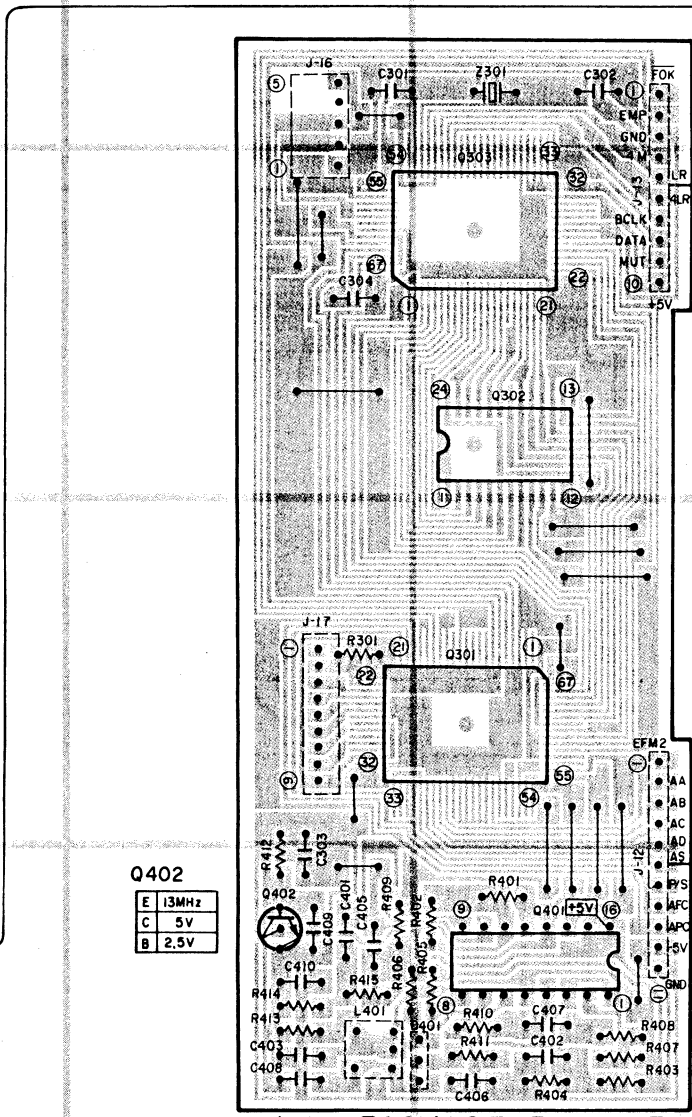

FLAT PACKAGE P.C. BOARD

Q402

E	13MHz
C	5V
B	2.5V

LOADING MOTOR P.C. BOARD

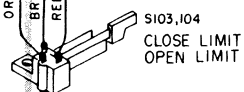
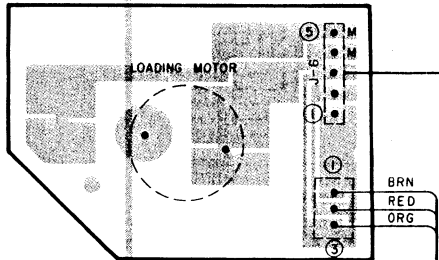

Q102

C	5V
	(0V)
	0V
B	(0.7V)

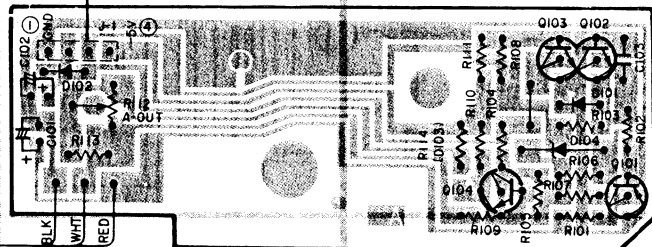

MECHANISM P.C. BOARD

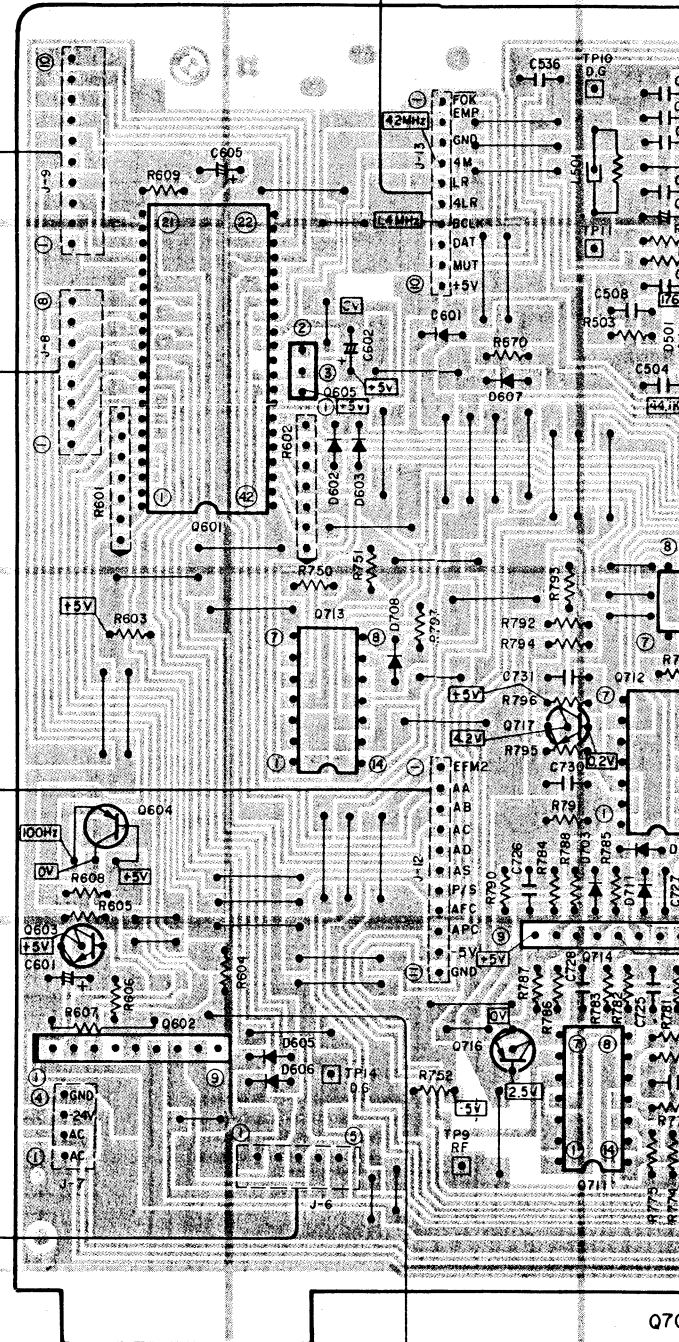

MECH.

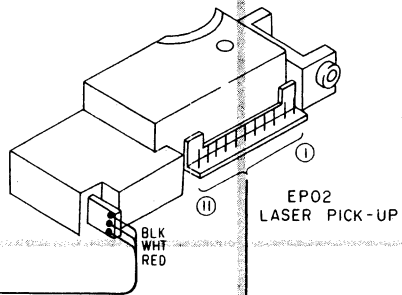

*The voltage values are measured without disc when power is ON.
The voltage values included in () are measured at PLAY mode.

Q706	E	0V
	B	0.7V
	(-1.1V)	

Q708	E	+5V
	C	-16V
	(+5V)	

Q702	B	0.7V
	(0V)	
	(+4.2V)	

Q726	E	+5V
	C	5V
	(-16V)	

MAIN P.C. BOARD

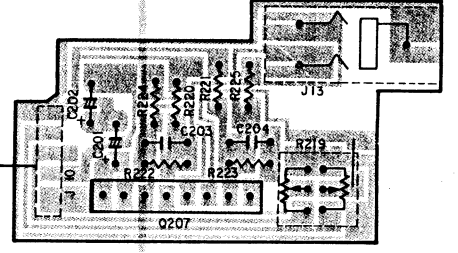
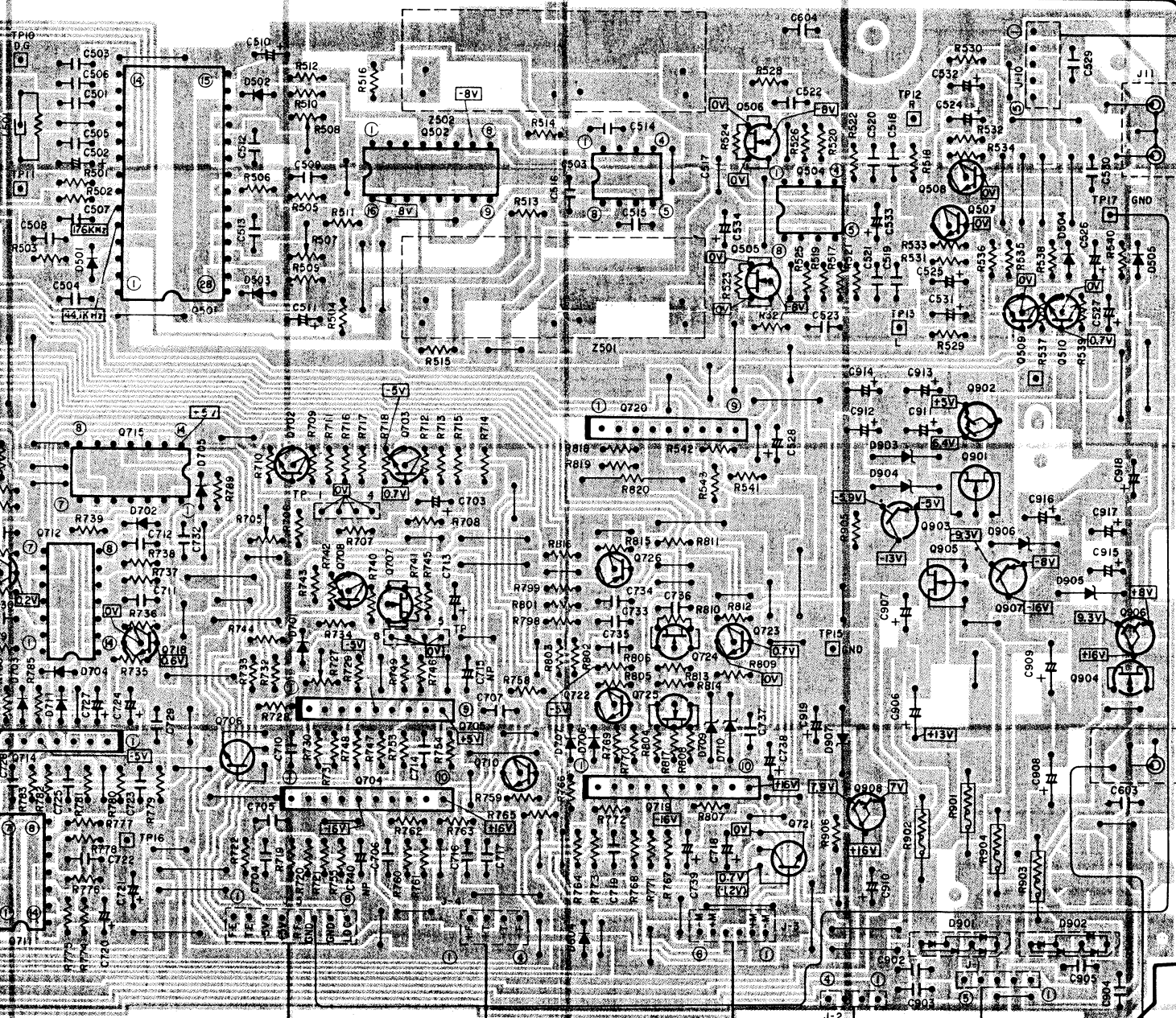

HEADPHONE P.C. BOARD

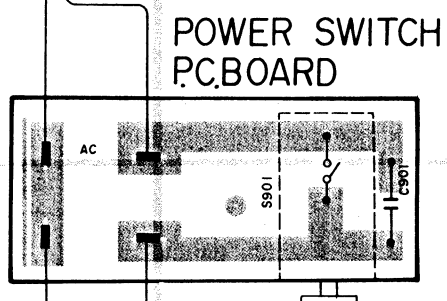
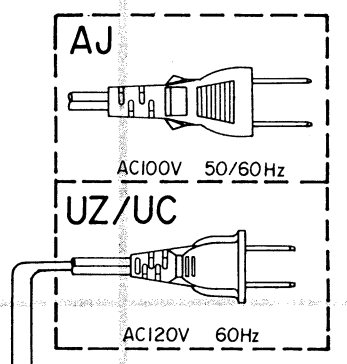
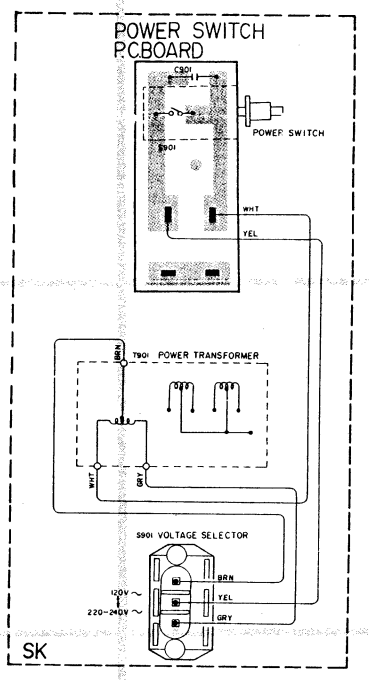

POWER SWITCH P.C. BOARD



POWER SWITCH

Q706	E	0V
	B	0.7V
	(-1.1V)	

Q707	G	-16V
	(0.5V)	

Q710	E	0V
	B	0.7V
	(-1.2V)	

Q722	E	0V
	B	0.7V
	(-1V)	

Q725	G	0.6V
	(-15V)	

Q724	G	0.6V
	(-15V)	

DRIVE MOTOR P.C. BOARD

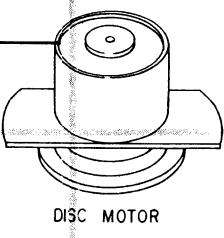
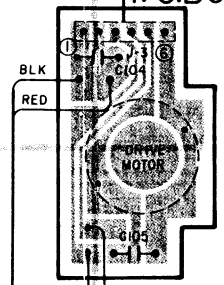

DISC MOTOR

POWER TRANSFORMER P.C. BOARD

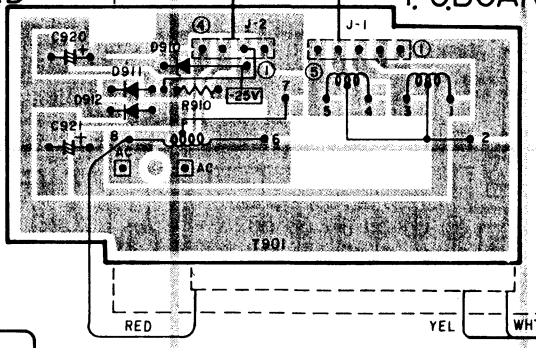

MECHANISM APC P.C. BOARD

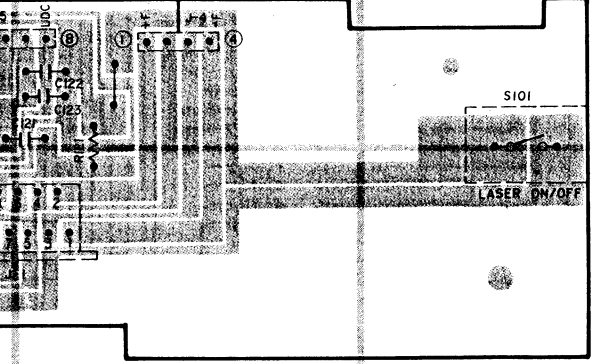

S102 START LIMIT

G

H

K

L