

DENON

For Europe & U.K. model

Version 2

SERVICE MANUAL

MODEL UD-M31

STEREO CD RECEIVER

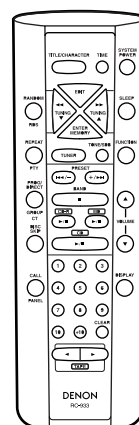
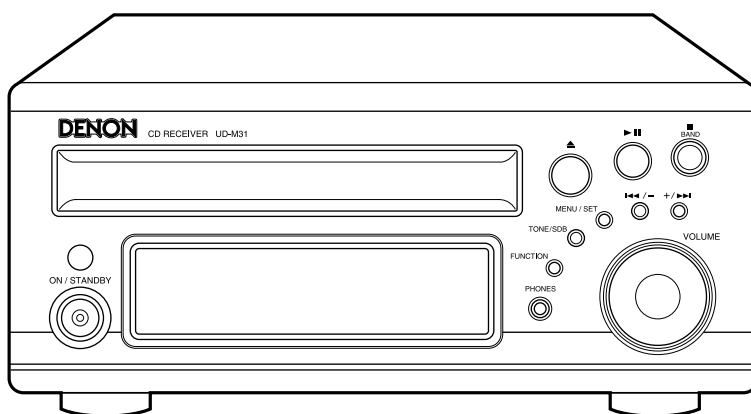

● Some illustrations using in this service manual are slightly different from the actual set.

DENON, Ltd.

16-11, YUSHIMA 3-CHOME, BUNKYOU-KU, TOKYO 113-0034 JAPAN
Telephone: 03 (3837) 5321

SAFETY PRECAUTIONS

The following check should be performed for the continued protection of the customer and service technician.

LEAKAGE CURRENT CHECK

Before returning the unit to the customer, make sure you make either (1) a leakage current check or (2) a line to chassis resistance check. If the leakage current exceeds 0.5 milliamps, or if the resistance from chassis to either side of the power cord is less than 460 kohms, the unit is defective.

DISASSEMBLY

(Follow the procedure below in reverse order when reassembling)

1. TOP COVER

- (1) Remove 2 screws ① on both sides.
- (2) Remove 5 screws ② on the rear.
- (3) Detach the Top Cover to the arrow direction.

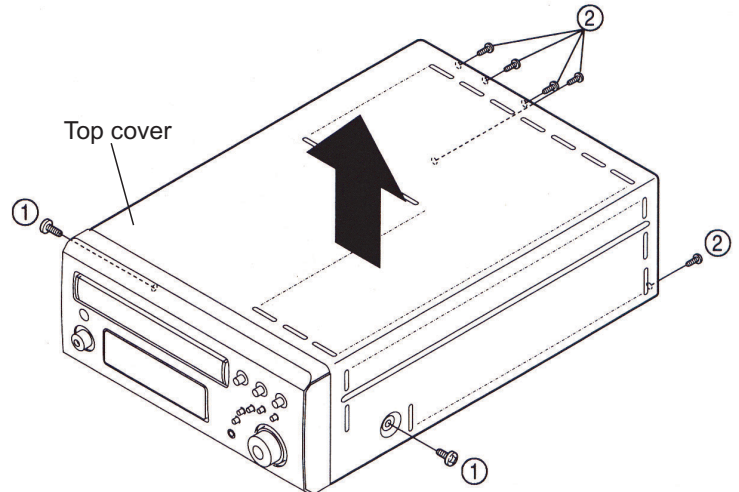

2. FRONT PANEL

- (1) Disconnect FFC on the rear of the CD Mecha.
- (2) Remove 4 lower screws ③
- (3) Detach the Front Panel with releasing the hooks on both sides.

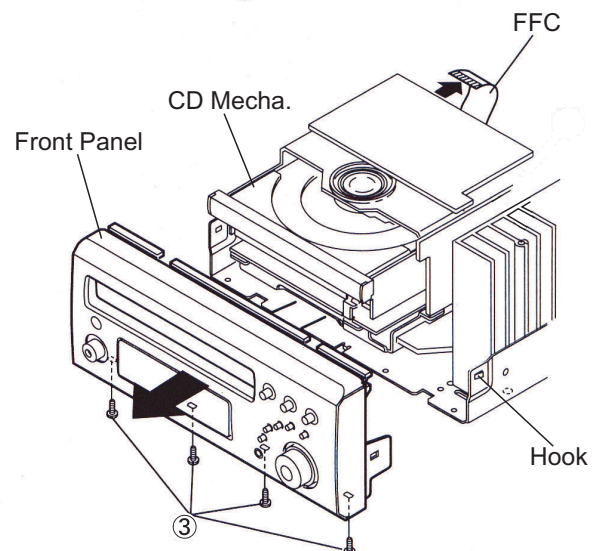

3. CD MECHANISM UNIT

- (1) Disconnect FFC coming from the top of the CD Mecha.
- (2) Unplug the connector on the rear of the μ com PWB.
- (3) Unplug the connector on the I/O PWB.
- (4) Remove 4 screws ④ on the μ com PWB.
- (5) Fully pull out the loader by turning the gear under the loader of the CD Mecha.
- (6) Remove 4 screws ⑤ to detach the CD Mecha.

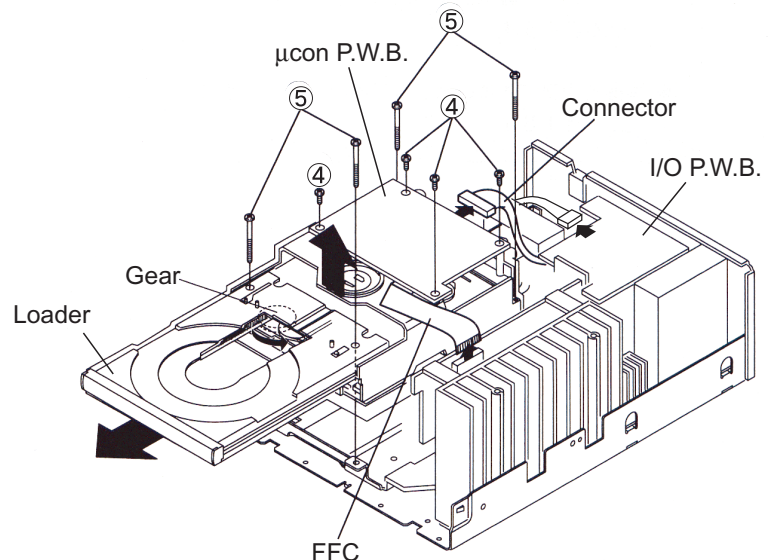

4. REAR PANEL

- (1) Pull out the cord bush.
- (2) Remove 12 screws ⑥.

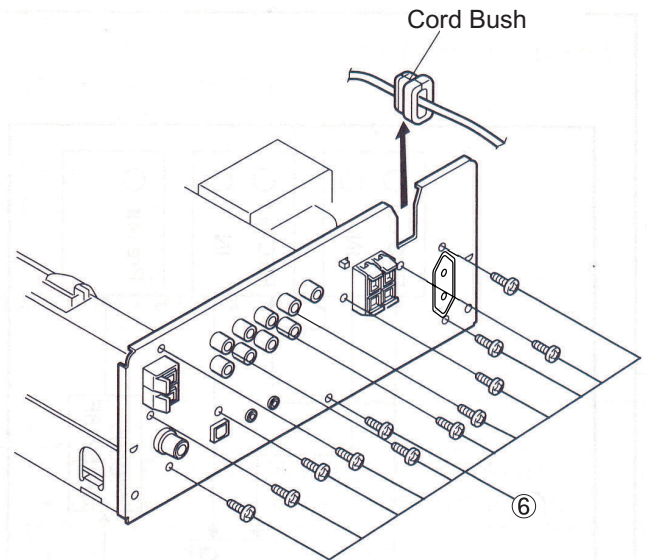

5. MAIN PWB

- (1) Remove 4 screws ⑦ fixing the radiator the chassis.
- (2) Unplug 3 connectors on the AMP PWB.
- (3) Detach the Main PWB together with the radiator .
- (4) Remove 5 screws ⑧ .
- (5) Detach the Power P.W.B.

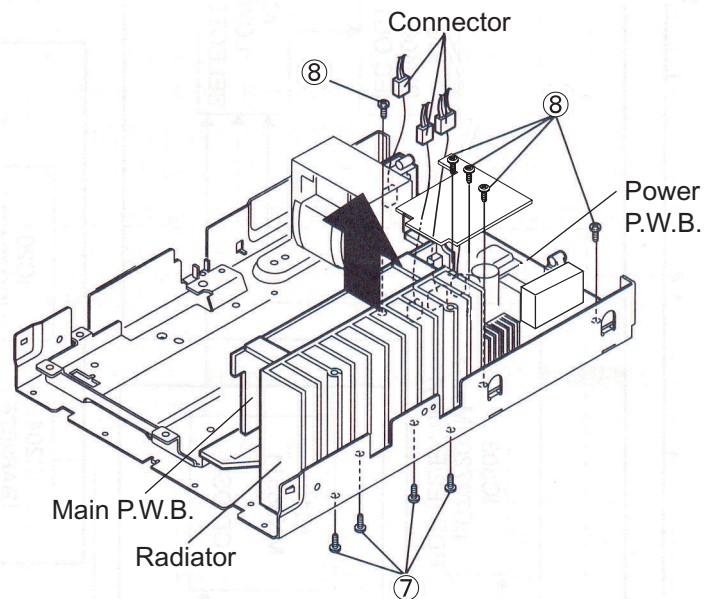

6. DISPLAY PWB

- (1) Pull out the VR knob.
- (2) Remove the spacer and the VR nut ⑨ .
- (3) Remove 7 screws ⑩ .

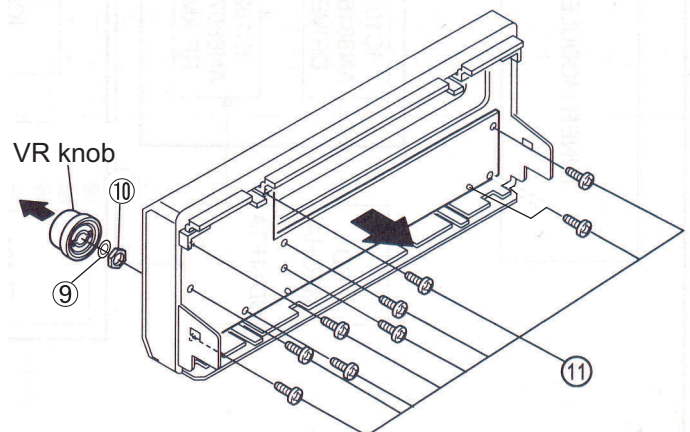

BLOCK DIAGRAM

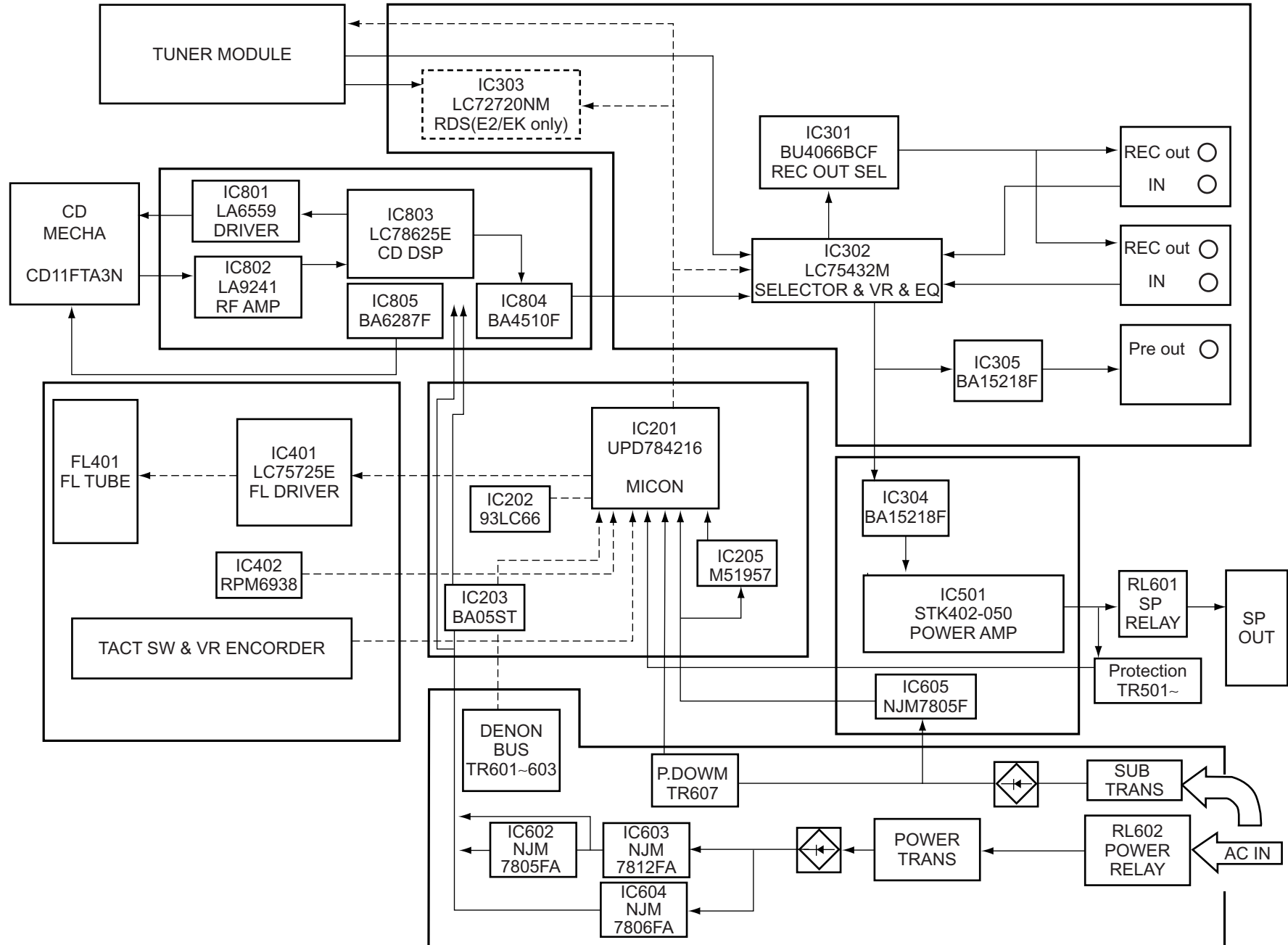

LEVEL DIAGRAM

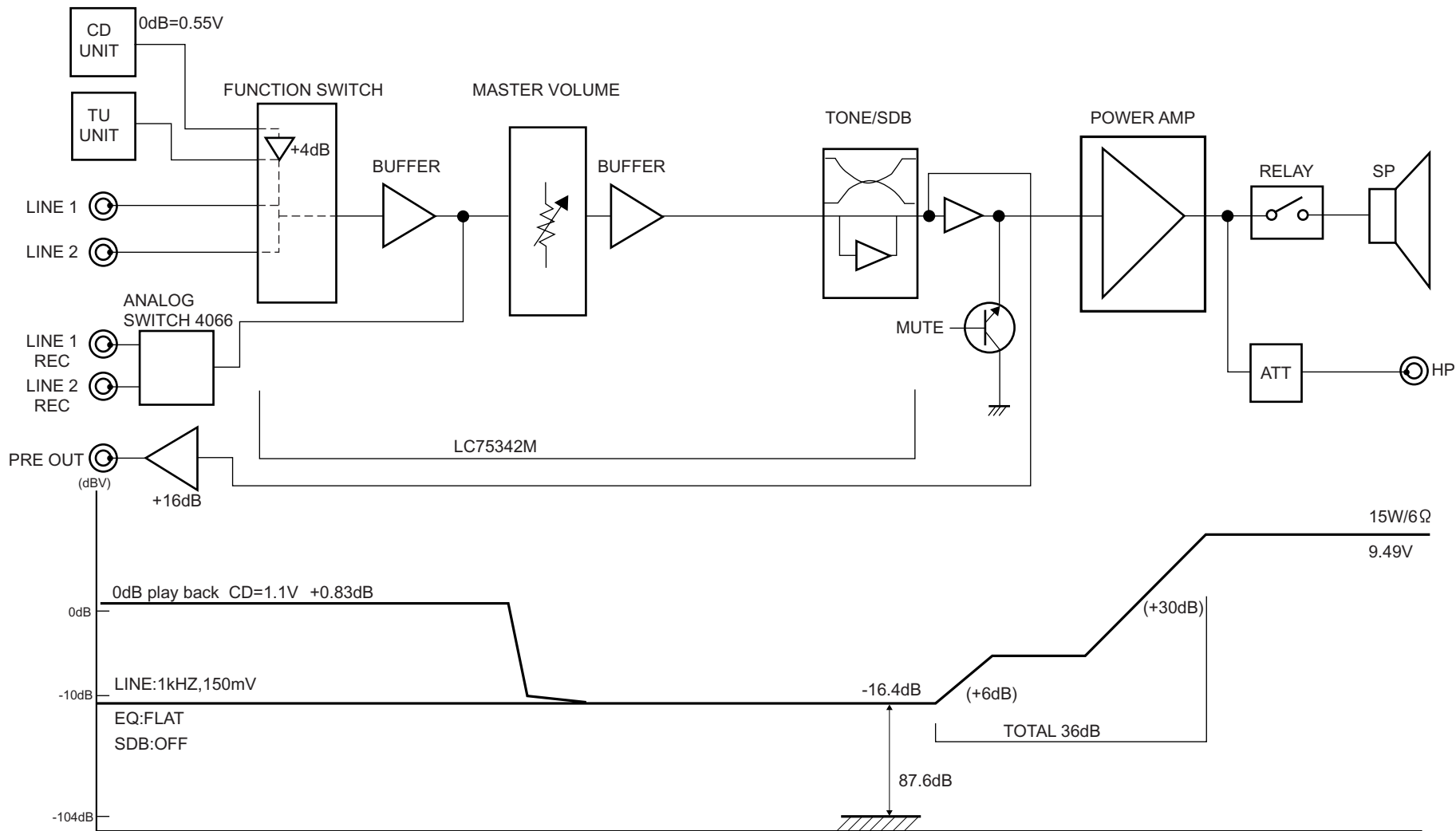

CD TEST MODE

● Setting of the test mode and explanation of each button

ITEM	OPERATION	FUNCTION	DISPLAY
1	Start the mode	Plug the AC cord to the wall outlet while pushing the POWER button and the Function button	1. Display "01" 2. The PLAY and the PAUSE mark lit
2	Disc load	1. Push the OPEN/CLOSE button and the LOADER open 2. Place the disc and push the OPEN/CLOSE button again	1. Display "01" 2. The PLAY and the PAUSE mark lit
3	Focus and Tracking check mode	1. Push the PLAY button 2. Push the PLAY button again 3. Push the PLAY button again	1. Display "02 L on" 2. Display "03 Fon" 3. Display "04 t on"
4	Move pick up	1. Push the SKIP forward button or the SKIP reverse button while stopping	The pick up move forward or reverse
5	Stop move	Push the STOP button	Stop the movement
6	All Servo on	Push the SKIP button	All servo on, and auto adjust
7	Clear this mode	Unplug the AC cord	

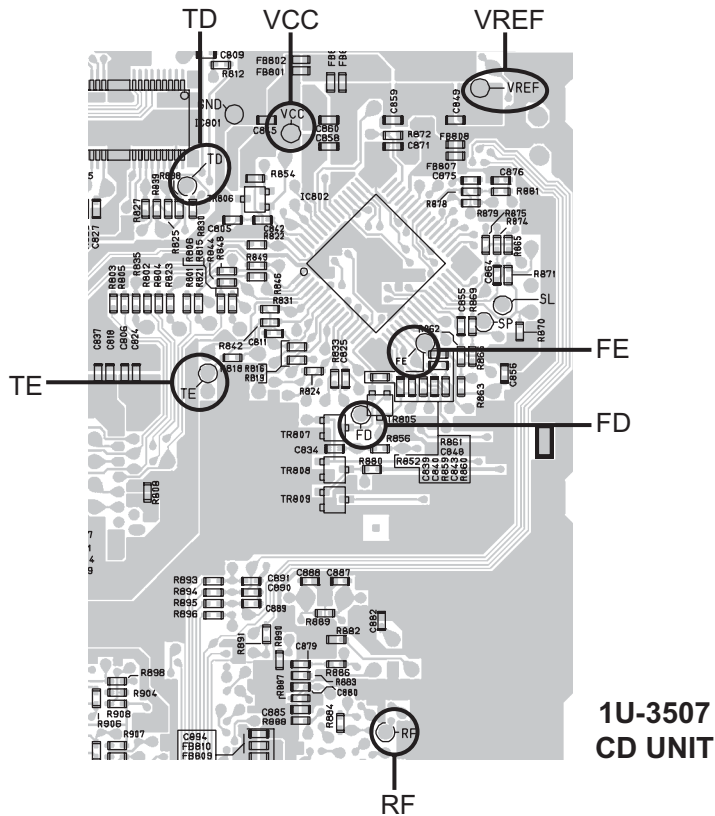

* Laser light of the pickup is always emitted regardless of DISC loading in the test mode. You may lose your eyesight if you look into the laser directly. So be careful enough when operating in the test mode.

● **How to check the test mode**

(1) DISC discrimination, adjustment

- * Insert DISC, and press the AUTO SEARCH REVERSE button.
- * "06 Adj" is displayed, and discrimination of DISC size 8 cm/12 cm, discrimination of DISC reflectance (CD, CD-R/CD-RW), adjustment of focus, tracking offset, and EF balance will be performed. (Adjusted values are not displayed: Refer to Fig. 2, 3)

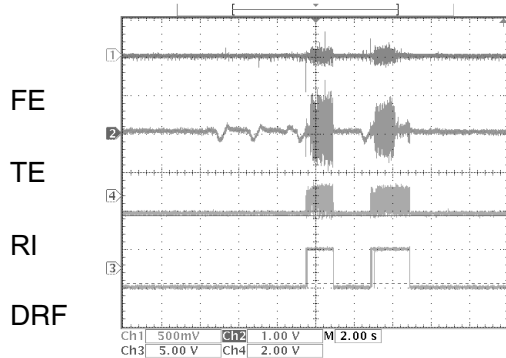

Fig. 2 DISC discrimination, adjustment (Case of CD-RW)

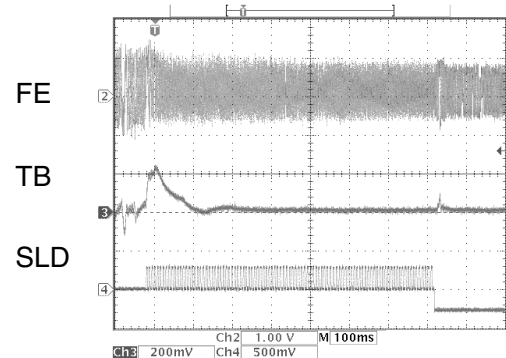

Fig. 3 Adjustment of EF balance

- * After completing the discrimination and adjustment, it becomes stop condition.
- * Once discrimination of DISC has been carried out in the "06 Adj" mode, discrimination of size and reflectance is no longer made, and only adjustment will be performed.

(2) Checking of servo state

- * Press the PLAY button after performing above (1) "DISC discrimination, adjustment".
- * "02 L on" is displayed, and the laser will start to light. (The pickup may vibrate with a rattling noise if DISC has been loaded, but this is not abnormal.)
- * Press the PLAY button again.
- * "03 F on" is displayed. DISC starts turning, and focus servo will be actuated. (Refer to Fig. 4, 5)

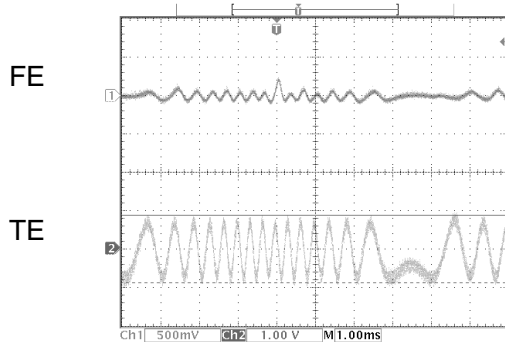

Fig. 4 In "03 F on"

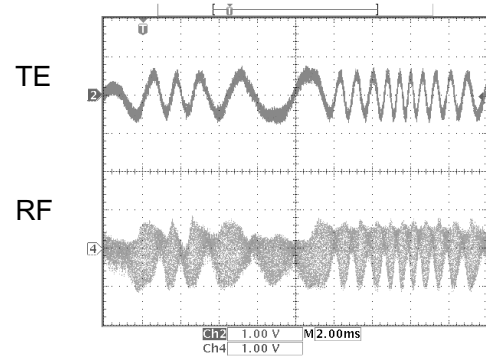

Fig. 5 In "03 F on"

- * Press the PLAY button again.
- * "04 t on" is displayed. Tracking, CLV, and slide servo will be actuated.
- * Monitor HF signal using the Test Point, HF point and VC point. Check that the signal's amplitude is $1.5V \pm 0.3V_{p-p}$. (Refer to Fig. 6)

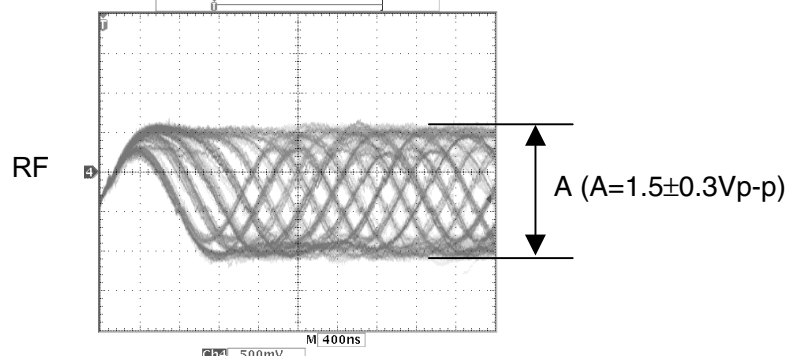
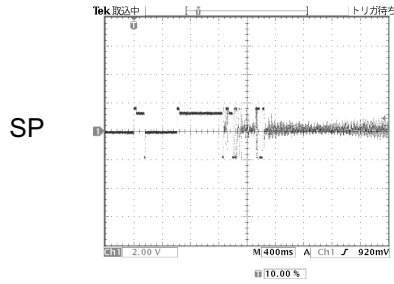
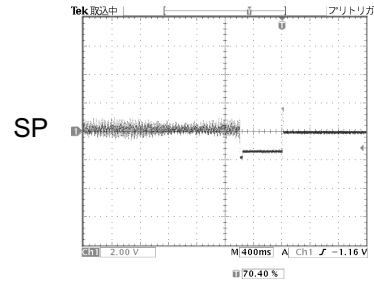

Fig. 6 In "04 t on"

WAVE-FORMS OF EACH POINT



When 12 cm DISC start



When 12 cm DISC stop

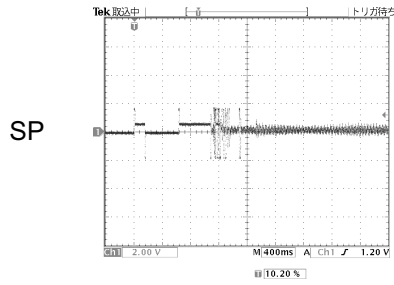

When 8 cm DISC start

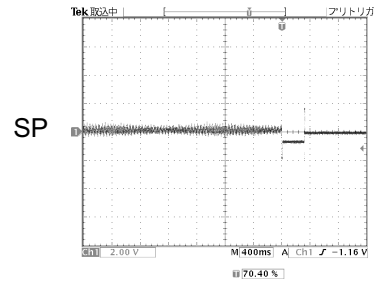

When 8 cm DISC stop

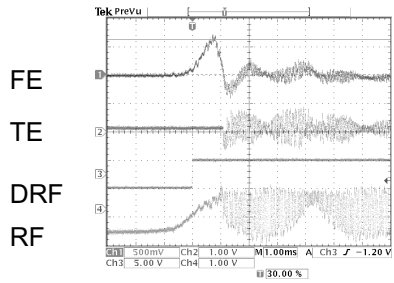

When focus servo on

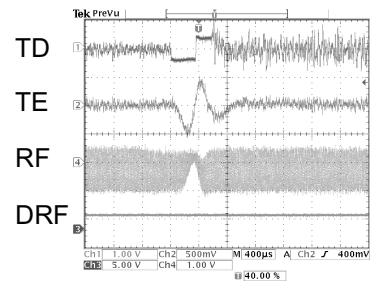

During PAUSE

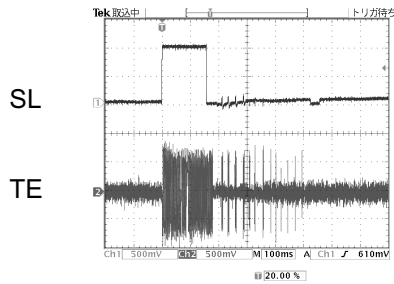

Track search (when forward)

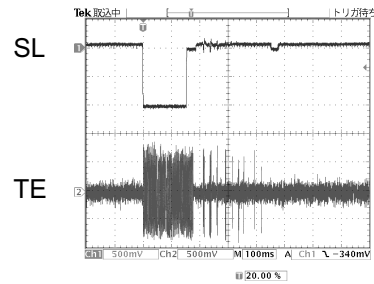

Track search (when reverse)

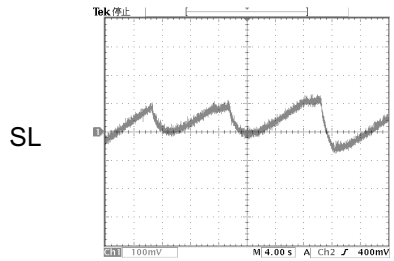

During PLAY

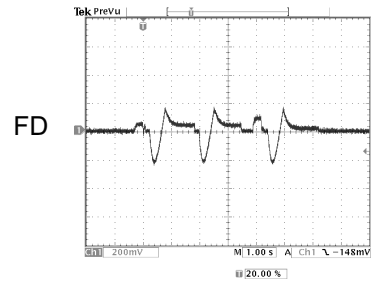

Focus search (no DISC)

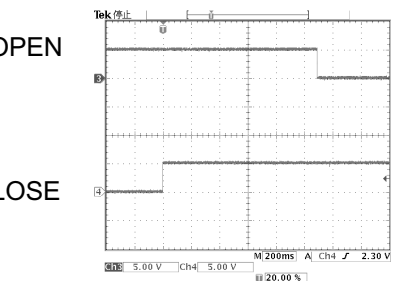

When the tray OPEN

CLOSE

SEMICONDUCTOR

●IC's
 μPD784216AGC-8EU(IC201)

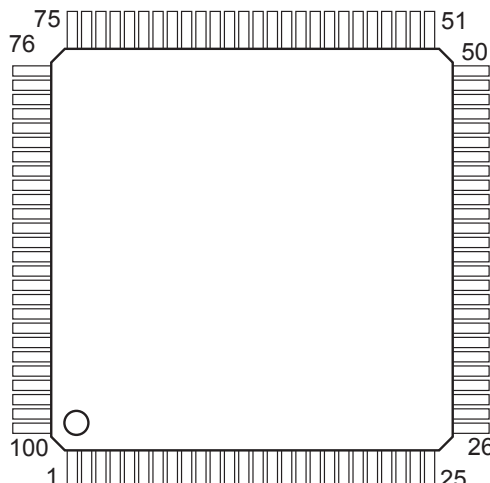

●μPD784216AGC-8EU Terminal Function

Pin No.	Port	Symbol	I/O	Function	RECIEVER or CD	outputs of standby&Default
1	P120/RTP0	ENC A	I	Rotary encoder INPUT A	RECIEVER	-
2	P121/RTP1	ENC B	I	Rotary encoder INPUT B	RECIEVER	-
3	P122/RTP2	V.MUTE	O	Volume mute output, mute;High	RECIEVER	H
4	P123/RTP3	POWER	O	Amp circuit power ON/OFF output, ON:High	RECIEVER	L
5	P124/RTP4	/R.MUTE	O	Speaker Relay ON/OFF output, ON:High	RECIEVER	L
6	P125/RTP5	NC	O	Not used :NC	OTHER	L
7	P126/RTP6	SEL.EEPROM	O	EEPROM chip enable output	RECIEVER	L
8	P127/RTP7	FLCE	O	Chip select output to FL tube controller	OTHER	L
9	VDD	VDD	-	Positive power	OTHER	-
10	X2	X2	-	X'tal connection for main clock oscillation	OTHER	-
11	X1	X1	I	X'tal connection for main clock oscillation	OTHER	-
12	VSS	VSS	-	GND potential	OTHER	-
13	XT2	XT2	-	x'tal connection for main sub-clock oscillation, not used : :NC		
14	XT1	XT1	I	x'tal connection for main sub-clock oscillation, not used :Connect to VSS orVCC		
15	/RESET	/RESET	I	Micro-computer reset input	OTHER	-
16	P00/INTP0	REMOCON	I	Remote-control receive data input	RECIEVER	-
17	P01/INTP1	50/60	I	50/60Hz AC input	RECIEVER	-
18	P02/INTP2/NMI	/DB RXD	I	DENON BUS Data input (interrupt input)	RECIEVER	-
19	P03/INTP3	PROTECT	I	Speaker Terminal DC voltage detect signal input	RECIEVER	-
20	P04/INTP4	SEL.EEPROM	O	EEPROM chip enable output	RECIEVER	L
21	P05/INTP5	WRQ	I	SUB CODE Q STAND BY	CD	L
22	P06/INTP6	/INT	I	NC, connect to grand	OTHER	-
23	AVDD	AVDD	-	A/D converter analog power	OTHER	-
24	AVref0	Avref0	-	A/D converter reference voltage input	OTHER	-
25	P10/ANI0	KEY1	I	Unit operation button input1	RECIEVER	-
26	P11/ANI1	KEY2	I	Unit operation button input2	RECIEVER	-
27	P12/ANI2	KEY3	I	Not used :Connect to GND	OTHER	-
28	P13/ANI3	KEY4	I	Not used :Connect to GND	OTHER	-
29	P14/ANI4	NC	I	Not used :Connect to GND	OTHER	-
30	P15/ANI5	DRF	I	REFLECTION OF DISC SIG. Input	CD	-
31	P16/ANI6	FSEQ	I	EFM SYNC SIG. INPUT	CD	-
32	P17/ANI7	DARXD	I	DATA BUS(for VOL,PLL,RDS IC, EEPROM) Data in	-	

Pin No.	Port	Symbol	I/O	Function	RECIEVER or CD	outputs of standby&Defout
33	AVSS	AVSS	-	A/D,D/A converter GND position	OTHER	-
34	P130/ANO0	LINE1	O	LINE OUT Control signal output1	OTHER	L
35	P131/ANO1	LINE2	O	LINE OUT Control signal output2	OTHER	L
36	AVref1	Avref1	-	D/A converter reference voltage input	OTHER	-
37	P70/RxD2/SI2	SQOUT	I	Sub Q code data input	CD	L
38	P71/TxD2/SO2	COIN	O	CD-DSP serial communication data output	CD	L
39	P72/ASCK2/SCK2	CQCK	O	CD-DSP serial communication clock output	CD	L
40	P20/RxD1/SI1	NC	I	Pull up	RECIEVER	-
41	P21/TxD1/SO1	FLDT	O	DATA BUS for FL driver, Data output	RECIEVER	L
42	P22/ACSK1/SCK1	FLCLK	O	DATA BUS for FL driver, Clock output	RECIEVER	L
43	P23/PCL	NC	I	Pull up	RECIEVER	-
44	P24/BUZ	/RDSRST	O	RDS IC reset output	RECIEVER	-
45	P25/SI0/SDA0	DB RXD	I	DATA BUS for DENON BUS Data input	RECIEVER	-
46	P26/SO0	DB TXD	O	DATA BUS for DEON BUS Data output	RECIEVER	L
47	P27/SCK0/SCL0	DB CLK	O	DENON BUS Clock output	RECIEVER	L
48	P80/A0	/SD	I	FM/AM Tuning signal input, Tuned:Low	RECIEVER	-
49	P81/AÇP	/ST INC	I	FM stereo demodulation detect input, Stereo:Low	RECIEVER	-
50	P82/A2	/TMUTE	O	Tuner mute output, mute:Low	RECIEVER	L
51	P83/A3	AUTO/MONO	O	FM AUTO/MONO switching, MONO:High	RECIEVER	L
52	P84/A4	USA	I	Initial setting input	RECIEVER	-
53	P85/A5	EURO	I	Initial setting input	RECIEVER	-
54	P86/A6	FREQ	I	Initial setting input	RECIEVER	-
55	P87/A7	RDS	I	Initial setting input	RECIEVER	-
56	P40/AD0	SL+	O	SLIDE kick Forward	CD	L
57	P41/AD1	SL-	O	SLIDE kick Reverse	CD	L
58	P42/AD2	CD/IRW	O	CD, CD-RW gain switching	CD	L
59	P43/AD3	SERACH	O	SEARCH control	CD	L
60	P44/AD4	NC	O	OPEN	CD	L
61	P45/AD5	NC	O	OPEN	CD	L
62	P46/AD6	LED POWER G	O	POWER/STANDBY Green LED output,Light:High		
63	P47/AD7	LED POWER R	O	POWER/STANDBY Red LED output,Light:High		
64	P50/A8	NC	I	Pull up	CD	-
65	P51/A9	NC	I	Pull up	CD	-
66	P52/A10	CLSW	I	LOADER CLOSE SW input	CD	-
67	P53/A11	OPSW	I	LOADER OPEN SW input	CD	-
68	P54/A12	NC	I	Pull up	CD	-
69	P55/A13	NC	I	Pull up	CD	-
70	P56/A14	NC	I	Pull up	CD	-
71	P57/A15		O	Not used :NC	OTHER	L
72	VSS	VSS	-	GND potential	OTHER	-
73	P60/A16	BLK	O	FLD ON/OFF control port, L= black out FLD		
74	P61/A17	DATXD	O	DATA BUS(for VOL,PLL,RDS IC, EEPROM) Data output	RECIEVER	L
75	P62/A18	DACLK	O	DATA BUS(for VOL,PLL,RDS IC, EEPROM) Clock output	RECIEVER	L
76	P63/A19	DACE	O	DATA BUS(for VOL,PLL,RDS IC) Chip enable output	RECIEVER	L
77	P64/RD	DRP_RST	O	CD-DSP reset output, output, reset:High	CD	L
78	P65/WR		O	Not used :NC	OTHER	L
79	P66/WAIT	PWBCHK	I	Start PWB check mode	OTHER	-

Pin No.	Port	Symbol	I/O	Function	RECIEVER or CD	outputs of standby&Defout
80	P67/ASTB		O	Not used :NC	OTHER	L
81	VDD	VDD	-	Positive power	OTHER	-
82	P100/TI5/TO5	OPEN	O	CD mecha. Open	CD	L
83	P101/TI6/TO6	CLOSE	O	CD mecha. Close	CD	L
84	P102/TI7/TO7	O	NC	OTHER	L	
85	P103/TI8/TO8	O	NC	OTHER	L	
86	P30/TO0	RWC	O	CD-DSP serial communication read / write	CD	L
87	P31/TO1		O	Not used :NC	OTHER	L
88	P32/TO2	DRV_MUTE	O	DRIVER MUTE	CD	L
89	P33/TI1		O	Not used :NC,	CD	L
90	P34/TI2	CDPOWER	O	CD power control signal output	CD	L
91	P35/TI00		O	Not used :NC,	OTHER	L
92	P36/TI02		O	Not used :NC	OTHER	L
93	P37	HPSW	I	HEADPHONE Insertswitch detective signal input		
94	TEST/VPP	TEST	I	not used :Connect to GND	OTHER	-
95	P90		O	Not used :NC,	OTHER	L
96	P91	OPSW	I	Pickup inner-most detect input, inner most:Low at on	-	
97	P92		O	Not used :NC	OTHER	L
98	P93		O	Not used :NC	OTHER	L
99	P94		O	Not used :NC	OTHER	L
100	P95		O	Not used :NC	OTHER	L

LC78625E(IC803)

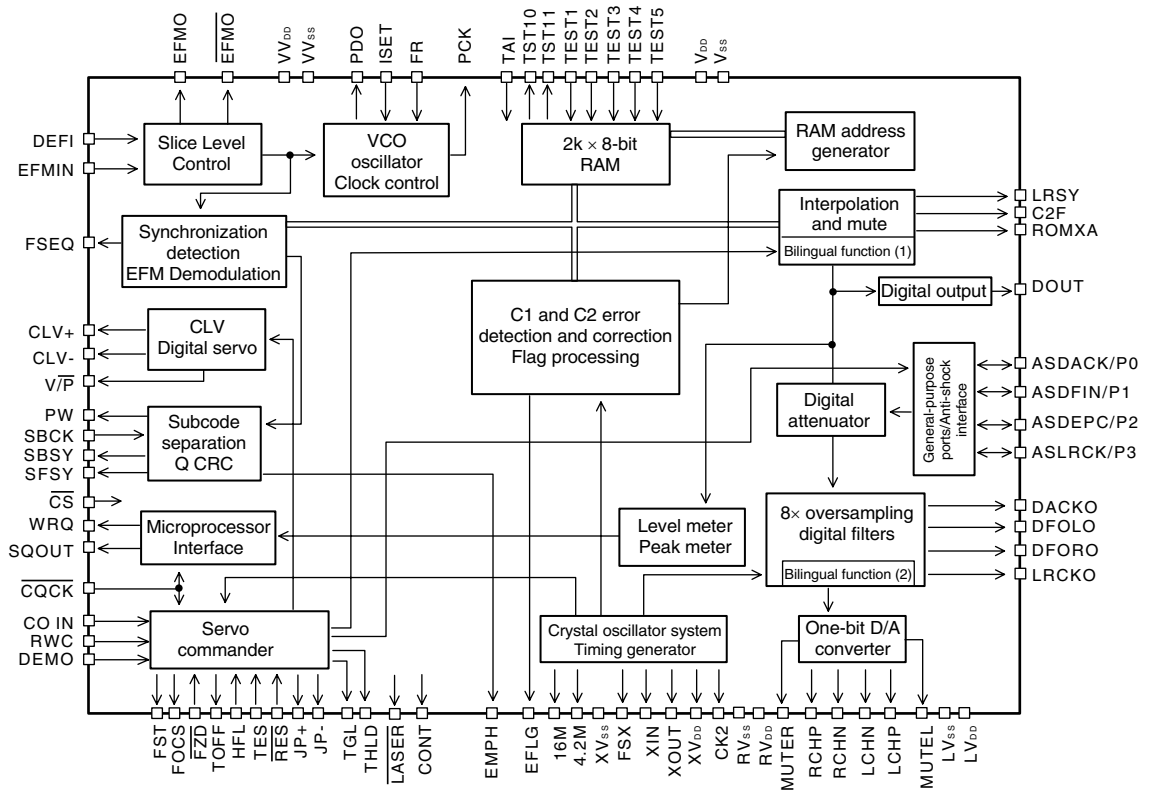
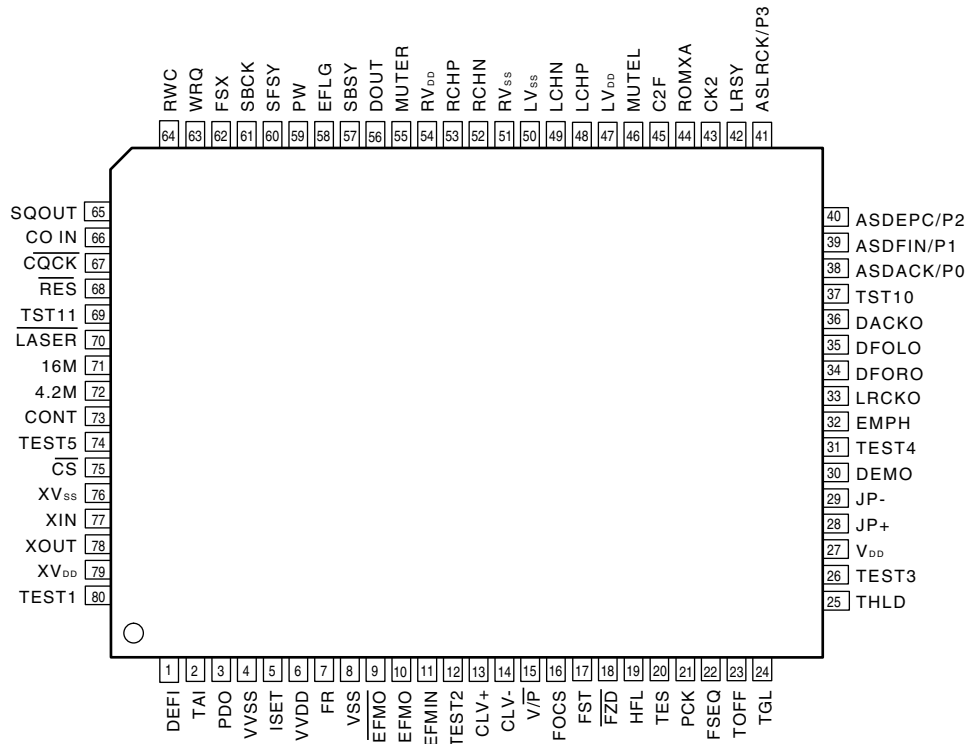

●LC78625E Terminal Function

PinNo.	Symbol	I/O	Function	
1	DEFI	I	Defect detection signal (DEF) input (This pin must be connected to 0 V if unused.)	
2	TAI	I	PLL pins	Test input. A pull-down resistor is built in. (This pin must be connected to 0 V in normal operation.)
3	PDO	O		External VCO control phase comparator output
4	VV _{SS}			Internal VCO ground. (This pin must be connected to 0 V.) PLL pins
5	ISET	AI		PDO output current adjustment resistor connection
6	VV _{DD}			Internal VCO power supply.
7	FR	AI		VCO frequency range adjustment
8	VSS			Digital system ground. (This pin must be connected to 0 V.)
9	EFM \bar{O}	O	Slice level control	EFM signal inverted output
10	EFMO	O		EFM signal output
11	EFMIN	I		EFM signal input
12	TEST2	I	Test input. A pull-down resistor is built in. This pin must be connected to 0 V in normal operation.	
13	CLV ⁺	O	Spindle servo control output. Acceleration when CLV ⁺ is high, deceleration when CLV ⁻ is high.	
14	CLV ⁻	O	Three-value output is also possible when specified by microprocessor command.	
15	$\bar{V/P}$	O	Rough servo/phase control automatic switching monitor output. Outputs a high level during rough servo and a low level during phase control.	
16	FOCS	O	Focus servo on/off output. Focus servo is on when the output is low.	
17	FST	O	Focus start pulse output. This is an open-drain output.	
18	\bar{FZD}	I	Focus error zero cross signal input. (This pin must be connected to 0 V if unused.)	
19	HFL	I	Track detection signal input. This is a Schmitt input.	
20	TES	I	Tracking error signal input. This is a Schmitt input	
21	PCK	O	EFM data playback clock monitor. Outputs 4.3218 MHz when the phase is locked.	
22	FSEQ	O	Synchronization signal detection output. Outputs a high level when the synchronization signal detected from the EFM signal and the internally generated synchronization signal agree.	
23	TOFF	O	Tracking off output	
24	TGL	O	Tracking gain switching output. Increase the gain when low.	
25	THLD	O	Tracking hold output	
26	TEST3	I	Test input. A pull-down resistor is built in. (This pin must be connected to 0 V.)	
27	V _{DD}		Digital system power supply.	
28	JP ⁺	O	Track jump output. A high level output from JP ⁺ indicates acceleration during an outward jump or deceleration during an inward jump.	
29	JP ⁻	O	A high level output from JP ⁻ indicates acceleration during an inward jump or deceleration during an outward jump. Three-value output is also possible when specified by microprocessor command.	
30	DEMO	I	Sound output function input used for end product adjustment manufacturing steps. A pull-down resistor is built in. (This pin must be connected to 0 V.)	
31	TEST4	I	Test input. A pull-down resistor is built in. (This pin must be connected to 0 V.)	
32	EMPH	O	De-emphasis monitor pin. A high level indicates playback of a de-emphasis disk.	
33	LRCKO	O	Digital filter outputs	Word clock output
34	DFORO	O		Right channel data output
35	DFOLO	O		Left channel data output
36	DACKO	O		Bit clock output
37	TST10	O	Test output. Leave open. (Normally outputs a low level.)	
38	ASDACK /P0	I/O	The antishock inputs in antishock mode. When antishock mode is not used, these pins are used as general purpose I/O ports (P0 to P3). They must either be set to input mode and connected to 0 V, or set to output mode and left open, if unused.	Bit clock input
39	ASDFIN/ P1	I/O		Left and right channel data input
40	ASDEPC /P2	I/O		Sets the built-in de-emphasis filter on or off. (High: on, low: off)
41	ASLRCK/ P3	I/O		L/R clock input

PinNo.	Symbol	I/O	Function		
42	LRSY	O	ROMXA application output signals	L/R clock output	
43	CK2	O		Bit clock output(after reset)	Inverted polarity clock output(during CK2CON mode)
44	ROMXA	O		Interpolation data output(after reset)	ROM data output (during ROMXA mode)
45	C2F	O		C2 flag output	
46	MUTEL	O	One-bit D/A converter signals	Left channel mute output	
47	LV _{DD}			Left channel power supply	
48	LCHP	O		Left channel P output	
49	LCHN	O		Left channel N output	
50	LV _{SS}			Left channel ground. Must be connected to 0 V.	
51	RV _{SS}			Right channel ground. Must be connected to 0 V.	
52	RCHN	O		Right channel N output	
53	RCHP	O		Right channel P output	
54	RV _{DD}			Right channel power supply	
55	MUTER	O		Right channel mute output	
56	DOUT	O	Digital output		
57	SBSY	O	Subcode block synchronization signal output		
58	EFLG	O	C1, C2, single and double error correction monitor pin		
59	PW	O	Subcode P, Q, R, S, T, U and W output		
60	SFSY	O	Subcode frame synchronization signal output. This signal falls when the subcodes are in the standby state.		
61	SBCK	I	Subcode readout clock input. This is a Schmitt input. (This pin must be connected to 0 V if unused.)		
62	FSX	O	Output for the 7.35 kHz synchronization signal divided from the crystal oscillator		
63	WRQ	O	Subcode Q output standby output		
64	RWC	I	Read/write control input. This is a Schmitt input.		
65	SQOUT	O	Subcode Q output		
66	COIN	I	Command input from the control microprocessor		
67	$\overline{\text{CQCK}}$	I	Input for the command input acquisition clock or the SQOUT pin subcode readout clock input. This is a Schmitt input.		
68	RES	I	Reset input. This pin must be set low briefly after power is first applied.		
69	TST11	O	Test output. Leave open. (Normally outputs a low level.)		
70	$\overline{\text{LASER}}$	O	Laser on/off output. Controlled by serial data commands from the control microprocessor.		
71	16M	O	16.9344 MHz output		
72	4.2M	O	4.2336 MHz output		
73	CONT	O	Supplementary control output. Controlled by serial data commands from the control microprocessor.		
74	TEST5	I	Test input. A pull-down resistor is built in. (This pin must be connected to 0 V.)		
75	$\overline{\text{CS}}$	I	Chip select input. A pull-down resistor is built in. This pin must be connected to 0 V if unused.		
76	XV _{SS}		Crystal oscillator ground. Must be connected to 0 V.		
77	XIN	I	Connections for a 16.9344 MHz crystal oscillator		
78	XOUT	O			
79	XV _{DD}		Crystal oscillator power supply		
80	TEST1	I	Test input. A pull-down resistor is built in. (This pin must be connected to 0 V.)		

Note: All power-supply pins (V_{DD}, VV_{DD}, LV_{DD}, RV_{DD}, and XV_{DD}) must be connected to the same potential.

LC75725E(IC401)

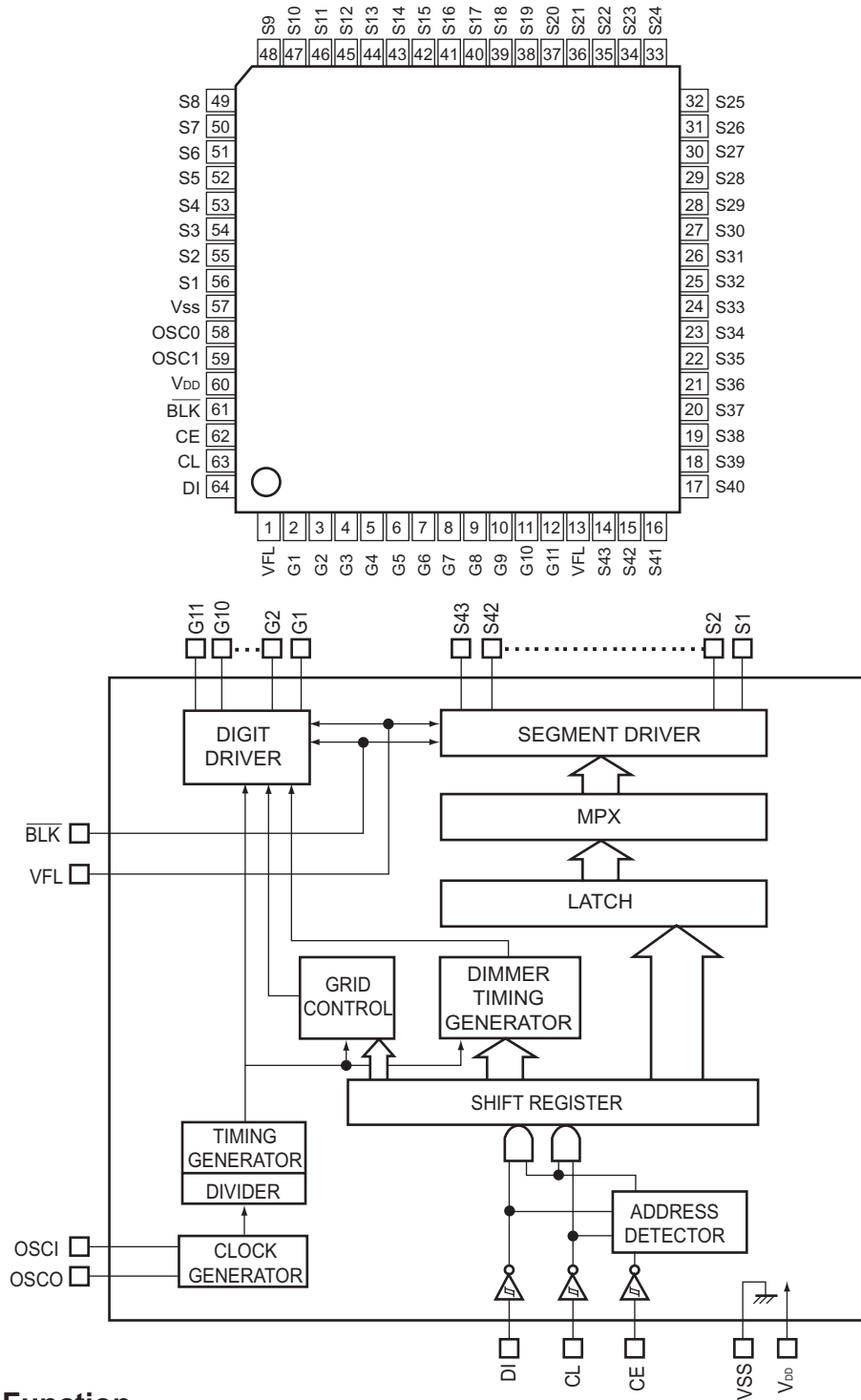

Terminal Function

Pin No.	I/O	Name	Function
1,13	-	VFL	Power supply pin to driver block
2~12	O	G1~G11	Digit output pin
14~56	O	S1~S43	Segment output pin
57	-	Vss	power supply pin
58	O	OSCO	Pin for oscillator
59	I	OSCI	Pin for oscillator
60	-	VDD	Power supply pin to logic block
61	I	BLK	Display off input pin
62	I	CE	Input for serial data transfer
63	I	CL	CE : Chip enable
			CL : Sync clock
			DI : Transfer data
64	I	DI	

LA9241M(IC802)

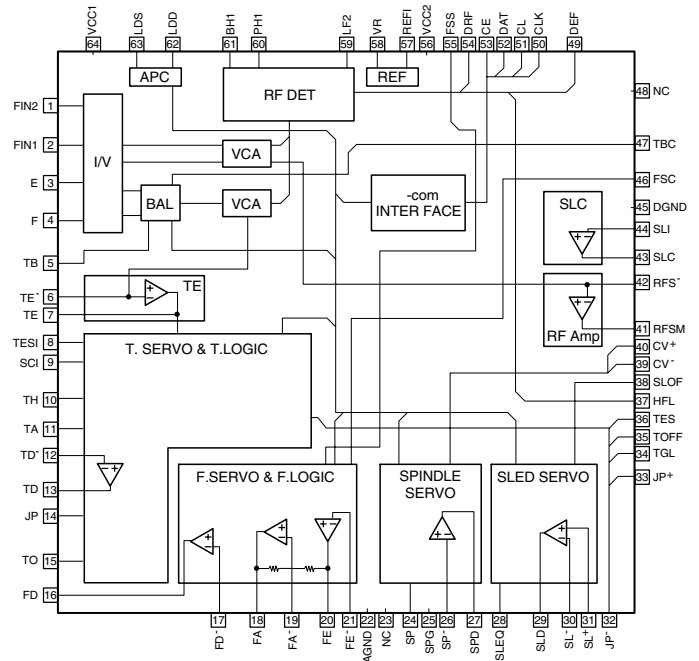
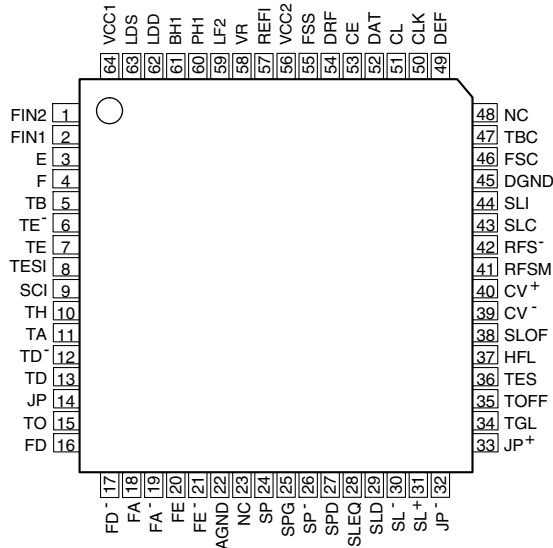

●LA9241M Terminal Function

PinNo.	Symbol	Contents
1	FIN2	Pickup photodiode connection pin. Added to FIN1 pin to generate the RF signal, subtracted from FIN1 pin to generate the FE signal.
2	FIN1	Pickup photodiode connection pin.
3	E	Pickup photodiode connection pin. Subtracted from F pin to generate the TE signal.
4	F	Pickup photodiode connection pin.
5	TB	TE signal DC component input pin.
6	TE-	Pin which connects the TE signal gain setting resistor between this pin and TE pin.
7	TE	TE signal output pin.
8	TESI	TES (Track Error Sense) comparator input pin. The TE signal is input through a bandpass filter.
9	SCI	Shock detection input pin.
10	TH	Tracking gain time constant setting pin.
11	TA	TA amplifier output pin.
12	TD-	Pin for configuring the tracking phase compensation constant between the TD and VR pins.
13	TD	Tracking phase compensation setting pin.
14	JP	Tracking jump signal (kick pulse) amplitude setting pin.
15	TO	Tracking control signal output pin.
16	FD	Focusing control signal output pin.
17	FD-	Pin for configuring the focusing phase compensation constant between the FD and FA pins.
18	FA	Pin for configuring the focusing phase compensation constant between the FD- and FA- pins.
19	FA-	Pin for configuring the focusing phase compensation constant between the FA and FE pins.
20	FE	FE signal output pin.
21	FE-	Pin which connects the FE signal gain setting resistor between this pin and FE pin.
22	AGND	Analog signal GND.
23	NC	No connection
24	SP	CV+ and CV- pins input signal single-end output.
25	SPG	12-cm spindle mode gain setting resistor connection pin.
26	SP-	Spindle phase compensation constant connection pin, along with the SPD pin.
27	SPD	Spindle control signal output pin.
28	SLEQ	Sled phase compensation constant connection pin.
29	SLD	Sled control signal output pin.
30	SL-	Input pin for sled movement signal from microprocessor.
31	SL+	Input pin for sled movement signal from microprocessor.

PinNo.	Symbol	Contents
32	JP ⁻	Input pin for tracking jump signal from DSP.
33	JP ⁺	Input pin for tracking jump signal from DSP.
34	TGL	Input pin for tracking gain control signal from DSP. Gain is low when TGL is high.
35	TOFF	Input pin for tracking off control signal from DSP. Tracking servo is off when TOFF is high.
36	TES	Output pin for TES signal to DSP.
37	HFL	The High Frequency Level is used to determine whether the main beam is positioned over a bit or over the mirrored
38	SLOF	Sled servo off control input pin
39	CV ⁻	Input pin for CLV error signal from DSP.
40	CV ⁺	Input pin for CLV error signal from DSP.
41	RFSM	RF output pin.
42	RFS ⁻	RF gain setting and EFM signal 3T compensation constant setting pin, along with the RFSM pin.
43	SLC	Slice Level Control is an output pin that controls the data slice level used by the DSP for the RF waveform.
44	SLI	Input pin used by DSP for controlling the data slice level.
45	DGND	Digital system GND pin.
46	FSC	Focus search smoothing capacitor output pin.
47	TBC	Tracking Balance Control; EF balance adjustment variable range setting pin
48	NC	No connection
49	DEF	Disc defect detection output pin.
50	CLK	Reference clock input pin. 4.23 MHz signal from the DSP is input.
51	CL	Microprocessor command clock input pin.
52	DAT	Microprocessor command data input pin.
53	CE	Microprocessor command chip enable input pin.
54	DRF	RF level detection output (Detect RF).
55	FSS	Focus Search Select; focus search mode (Å) search/+search vs. the reference voltage) switching pin
56	V _{CC2}	Servo system and digital system VCC pin.
57	REFI	By-pass capacitor connection pin for reference voltage.
58	VR	Reference voltage output pin.
59	LF2	Disc defect detection time constant setting pin.
60	PH1	RF signal peak hold capacitor connection pin.
61	BH1	RF signal bottom hold capacitor connection pin.
62	LDD	APC circuit output pin.
63	LDS	APC circuit input pin.
64	V _{CC1}	RF system VCC pin.

LA6559(IC801)

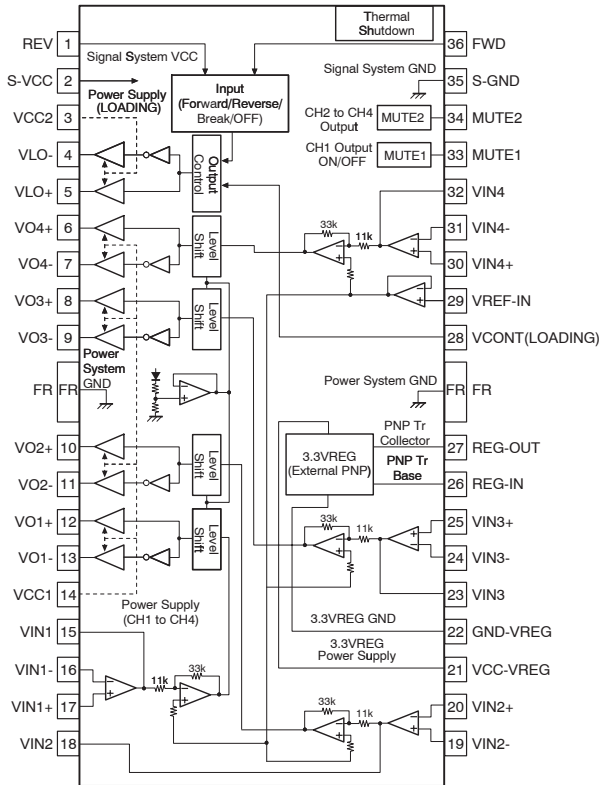

Pin No.	Name	Function
1	REV	5CH output change terminal, logic input of loading block
2	S-Vcc	signal system power supply (BTL-AMP:CH1~4)
3	Vcc2	Power supply for loading block
4	VLO-	Loading output (-)
5	VLO+	Loading output (+)
6	VO4+	Output terminal (+) for channel 4
7	VO4-	Output terminal (-) for channel 4
8	VO3+	Output terminal (+) for channel 3
9	VO3-	Output terminal (-) for channel 3
10	VO2+	Output terminal (+) for channel 2
11	VO2-	Output terminal (-) for channel 2
12	VO1+	Output terminal (+) for channel 1
13	VO1-	Output terminal (-) for channel 1
14	Vcc1	CH1 `CH4(BTL-AMP) output stage power supply
15	VIN1	Input terminal for channel 1
16	VIN1-	OP-AMP input AMP-A input terminal (-)
17	VIN1+	OP-AMP input AMP-A input terminal (+)
18	VIN2	Input terminal for channel 2, input AMP output
19	VIN2-	Input terminal (-) for channel 2
20	VIN2+	Input terminal (+) for channel 2
21	Vcc-VREG	3.3VREG power supply
22	GND-VREG	3.3VREG GND
23	VIN3	Input terminal for channel 3, input AMP output
24	VIN3-	Input terminal (-) for channel 3
25	VIN3+	Input terminal (+) for channel 3
26	REG-IN	PNP transistor base connected
27	REG-OUT	3.3V power output to which the PNP transistor collector connected
28	VCONT	Loading output voltage set terminal
29	VREF-IN	Reference voltage applied terminal
30	VIN4+	Input terminal (+) for channel 4
31	VIN4-	Input terminal (-) for channel 4
32	VIN4	Input terminal for channel 4, input AMP output
33	MUTE1	Output ON/OFF for channel 1 (BTL AMP)
34	MUTE2	Output ON/OFF for channel 2 to 4 (BTL AMP)
35	S-GND	Signal system GND
36	FWD	Output change terminal (FWD) for loading output (VLO+,-), logic input of loading block

LC75342M(IC302)

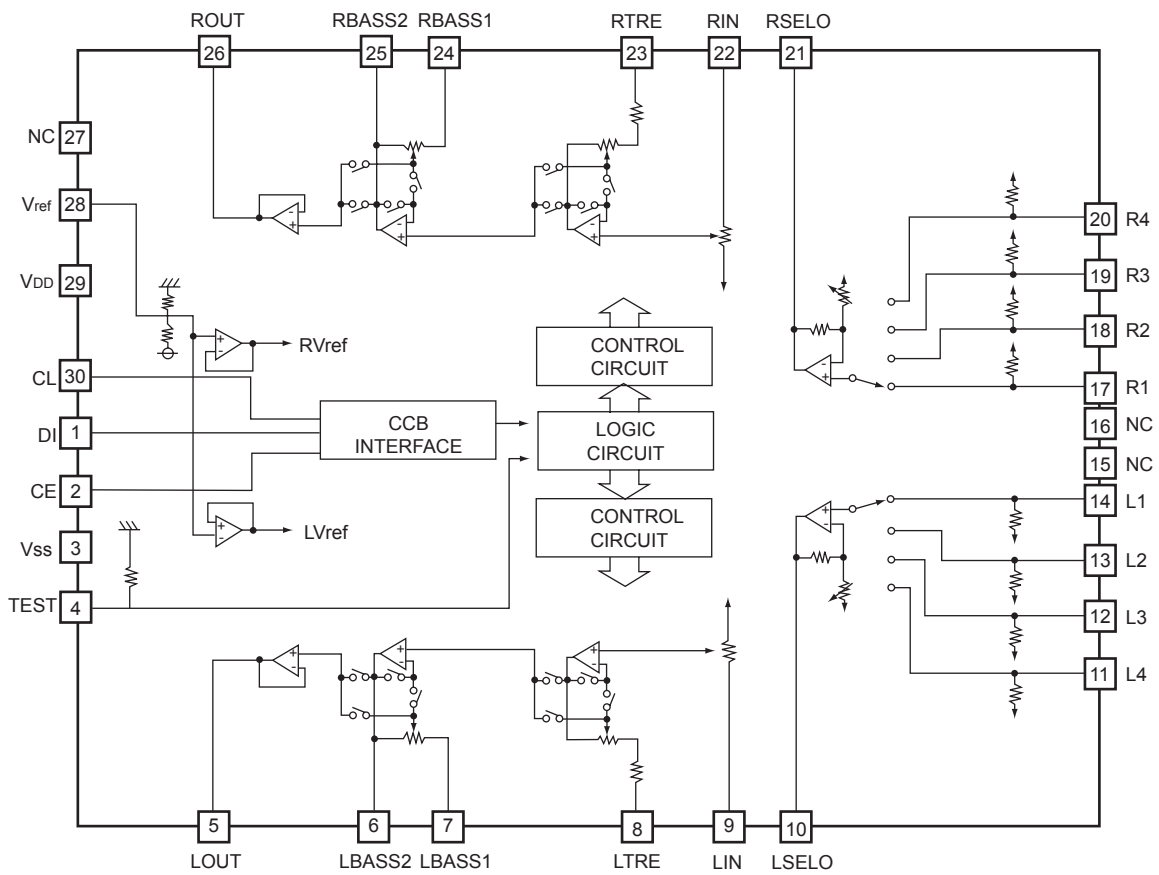
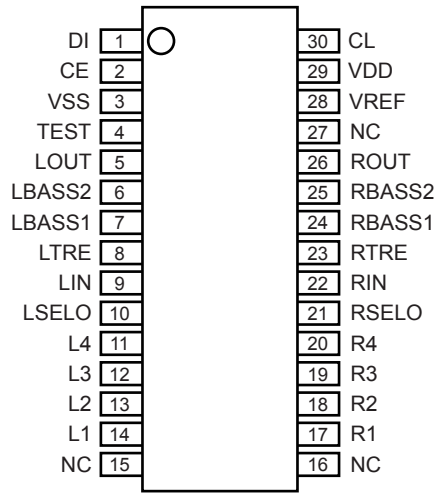

LC72720NM(IC303)

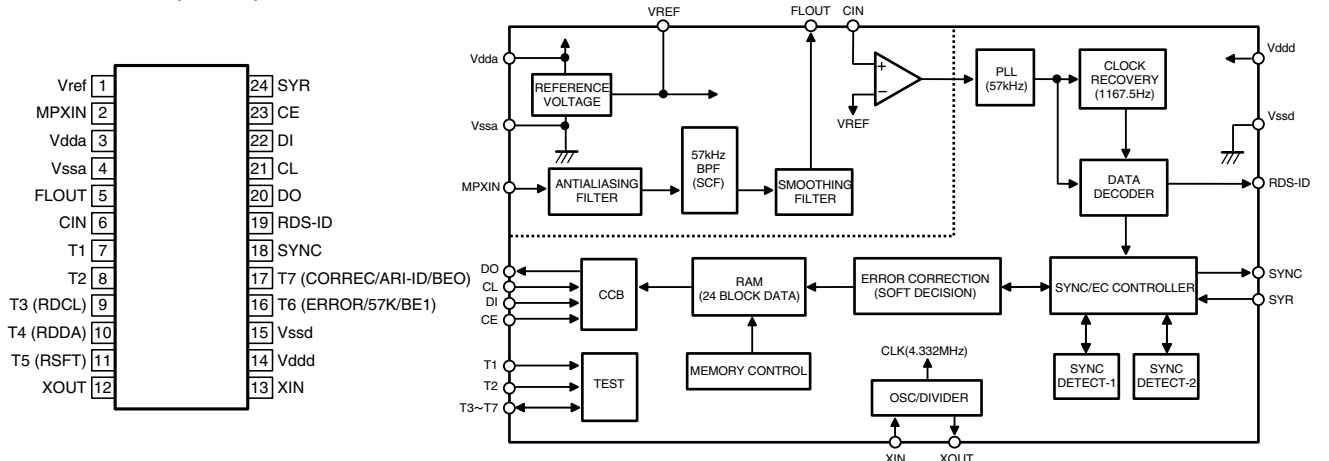

STK402-050(IC501)

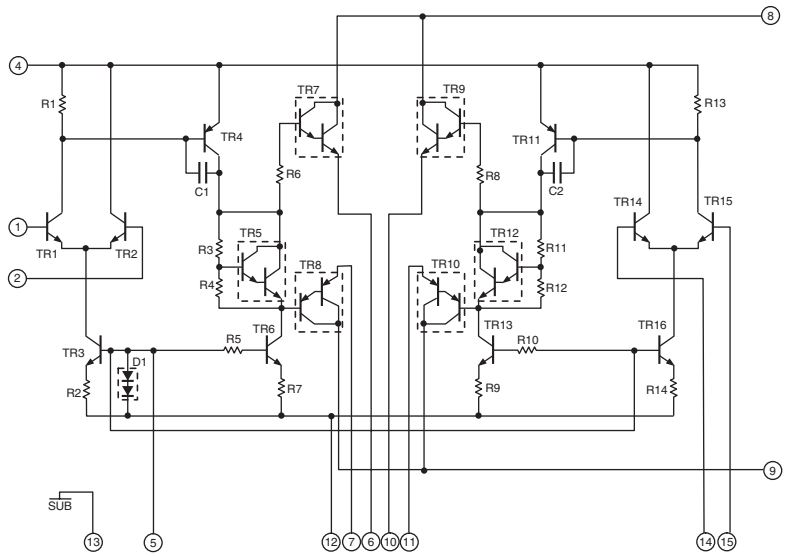
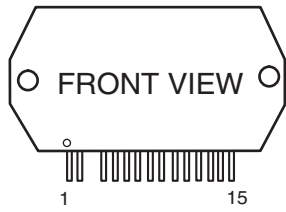

BA6287F(IC805)

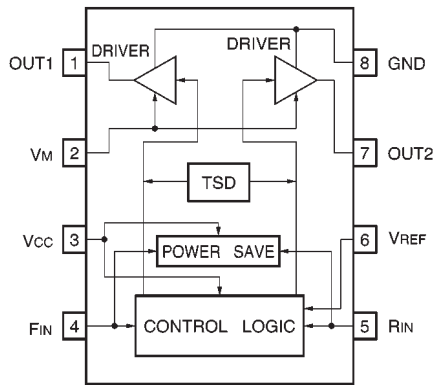

93LC66(IC202)

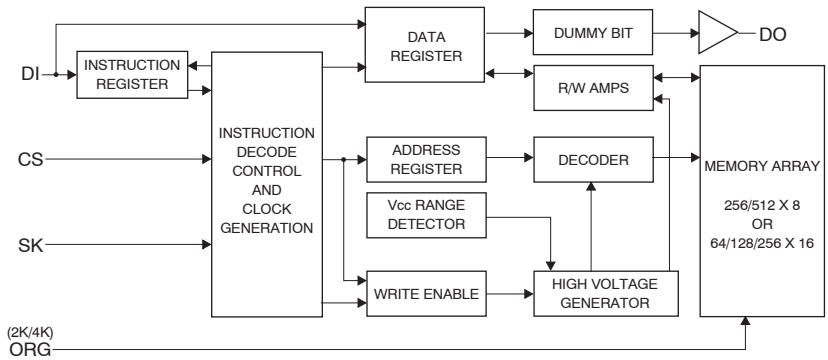
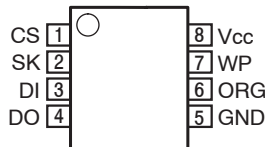

M51957BFP(IC205)

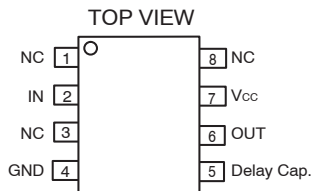

●FL DISPLAY HNA-11SS47T (FL401)

GRID ASSIGNMENT

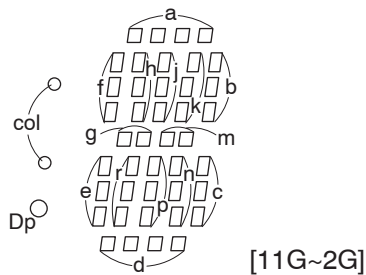
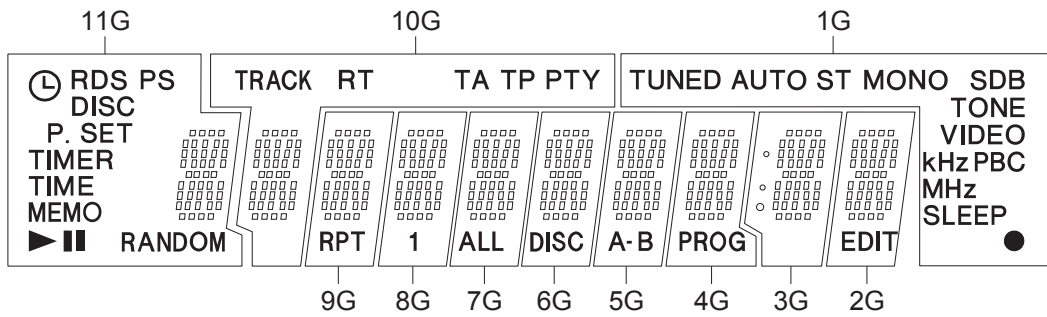

PIN CONNECTION

PIN NO.	4	4	4	4	4	3	3	3	3	3	3	3	3	2	2	2	2	2	2	2	2	1	1	1	1	1	1	1	1	1	1	8	7	6	5	4	3	2	1		
CONNECTION	F	F	N	N	1	2	3	4	5	6	7	8	9	0	1	N	2	2	2	2	2	1	1	1	1	1	1	1	1	P	P	P	P	P	P	P	P	N	N	F	F

NOTE

- 1) Fin ---- Filament pin
- 2) nG ---- Grid pin
- 3) Pn ---- Anode pin
- 4) NP ---- No pin
- 5) NC ---- No connection

PRINTED WIRING BOARD

1U-3498 MAIN UNIT Ass'y COMPONENT SIDE

Parts List

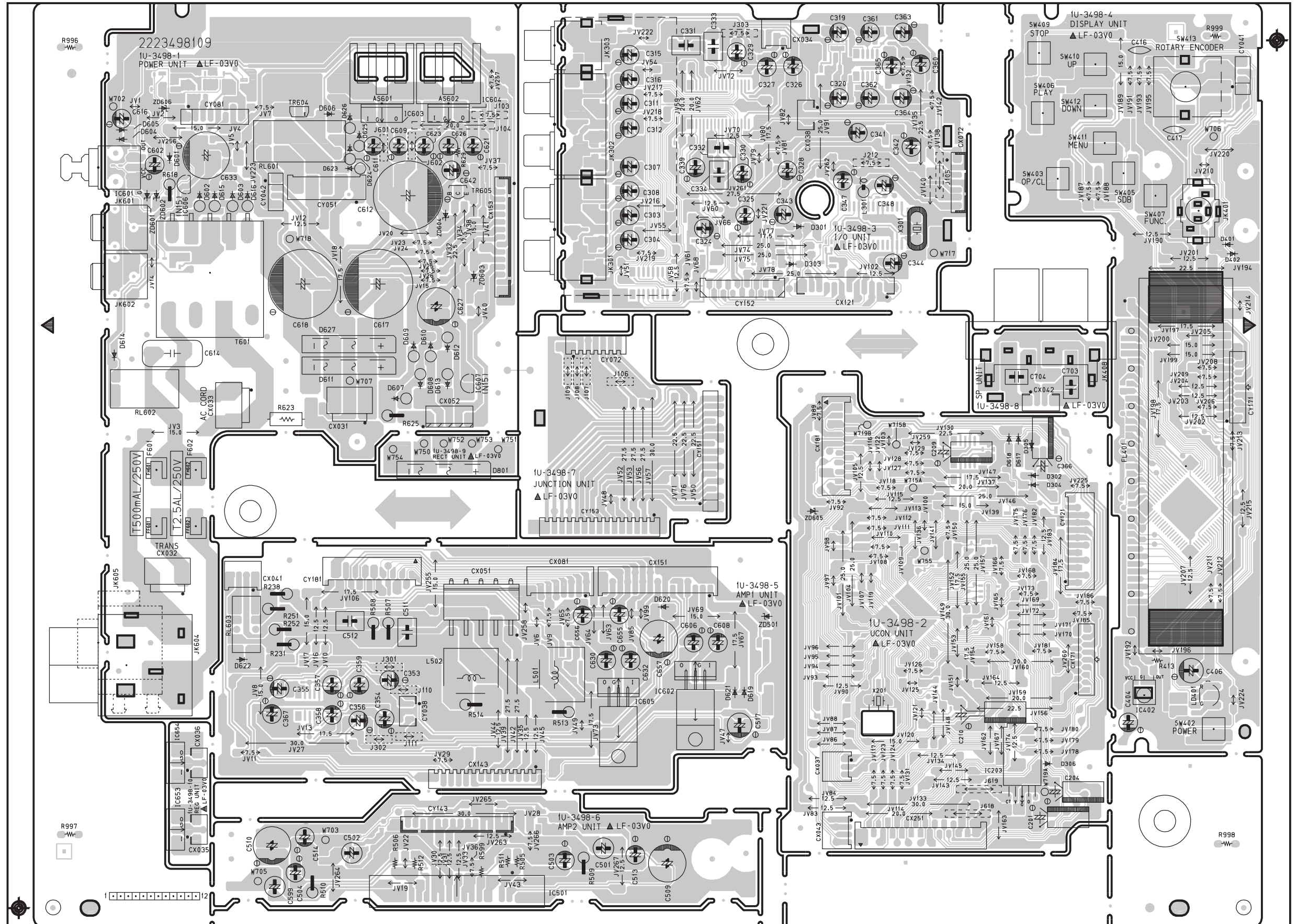

1U-3498 MAIN UNIT Ass'y FOIL SIDE

Parts List

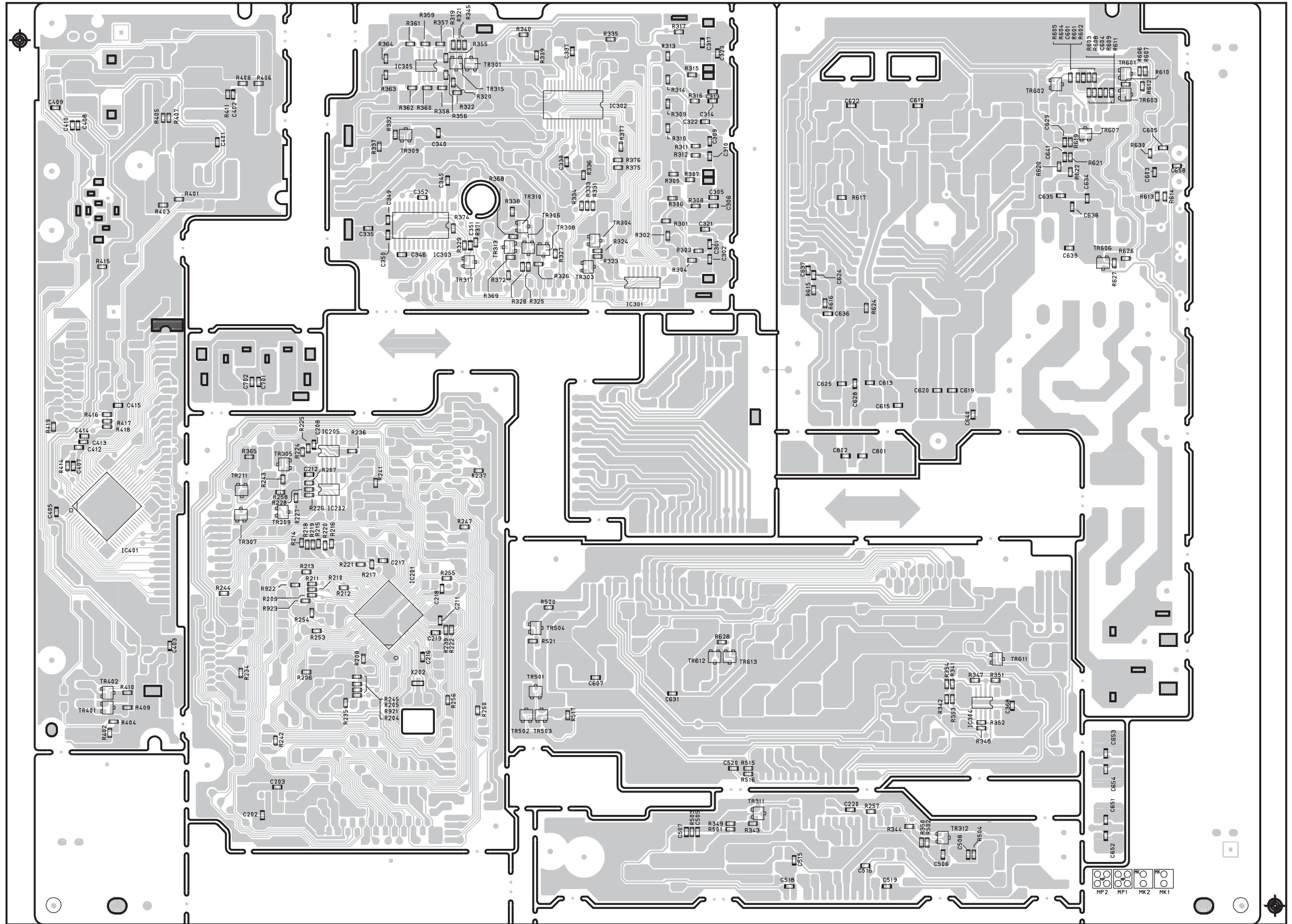

1U-3507 CD UNIT ASS'Y

Parts List

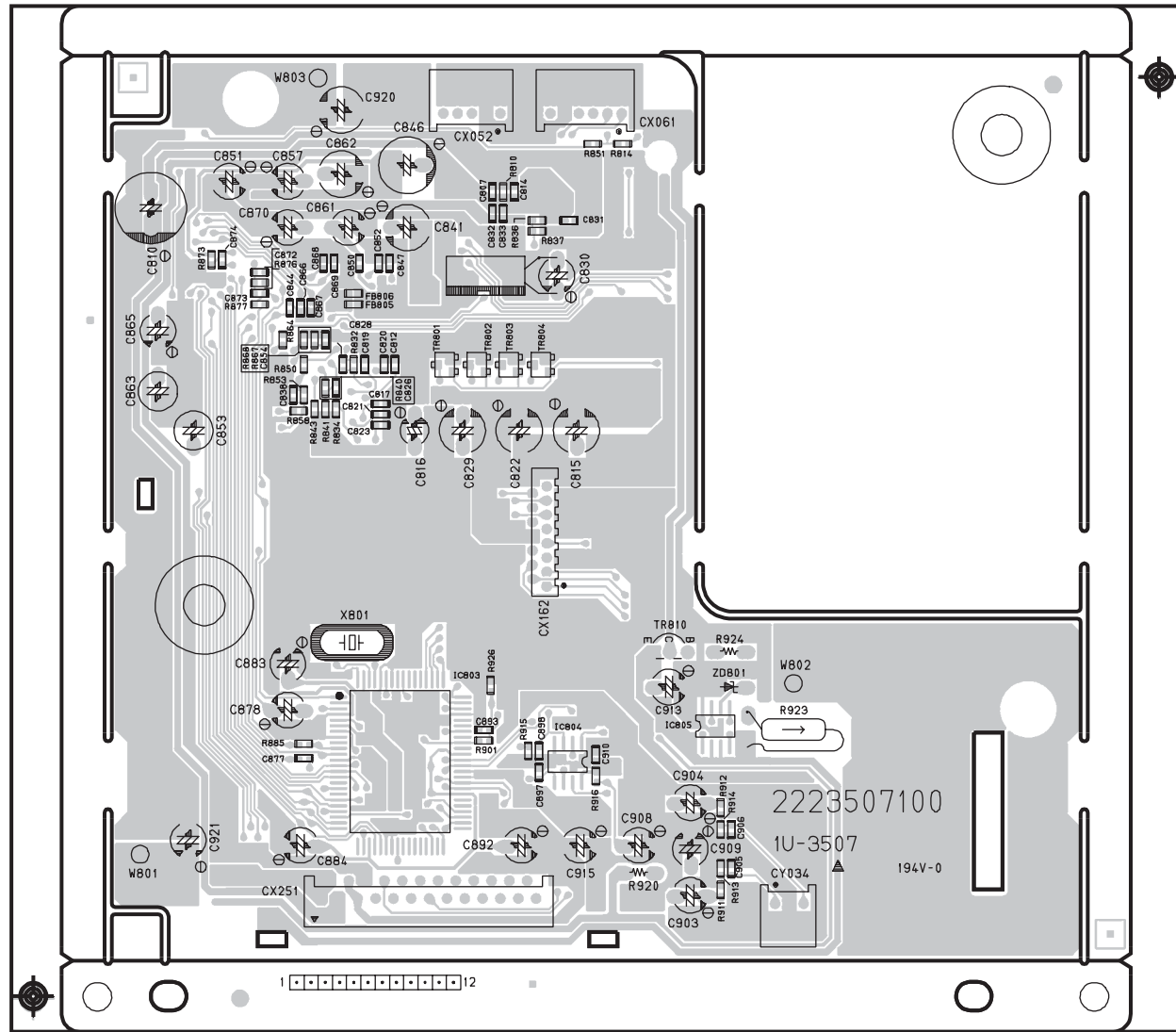

COMPONENT SIDE

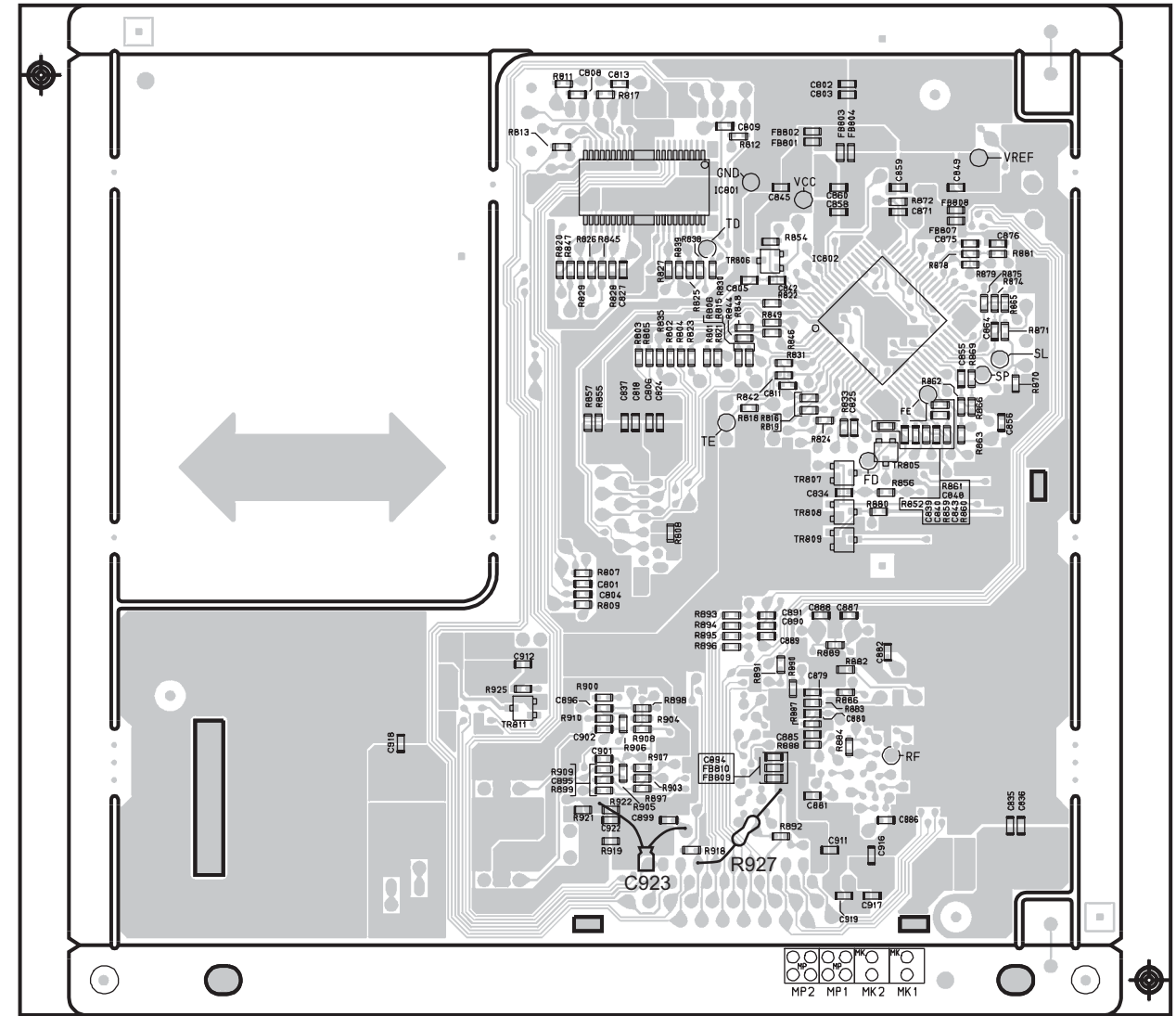

FOIL SIDE

NOTE FOR PARTS LIST

- Part indicated with the mark "◎" are not always in stock and possibly to take a long period of time for supplying, or in some case supplying of part may be refused.
 - When ordering of part, clearly indicate "1" and "I" (i) to avoid mis-supplying.
 - Ordering part without stating its part number can not be supplied.
 - Part indicated with the mark "★" is not illustrated in the exploded view.
 - Not including Carbon Film ±5%, 1/4W Type in the P.W.Board parts list. (Refer to the Schematic Diagram for those parts.)
- WARNING:**
 Parts marked with this symbol ⚠ have critical characteristics.
 Use ONLY replacement parts recommended by the manufacturer.

● Resistors

Ex.: RN 14K 2E 182 G FR
 Type Shape Power Resist- Allowable Others
 and- ance error
 performance

RD : Carbon	2B : 1/8W	F : ±1%	P : Pulse-resistant type
RC : Composition	2E : 1/4W	G : ±2%	NL : Low noise type
RS : Metal oxide film	2H : 1/2W	J : ±5%	NB : Non-burning type
RW : Winding	3A : 1W	K : ±10%	FR : Fuse-resistor
RN : Metal film	3D : 2W	M : ±20%	F : Lead wire forming
RK : Metal mixture	3F : 3W		
	3H : 5W		

*** Resistance**

1 8 2 ⇒ 1800 ohm = 1.8 kohm
 Indicates number of zeros after effective number.
 2-digit effective number.

• Units: ohm

1 R 2 ⇒ 1.2 ohm
 1-digit effective number.
 2-digit effective number, decimal point indicated by R.

• Units: ohm

● Capacitors

Ex.: CE 04W 1H 2R2 M BP
 Type Shape Dielectric Capacity Allowable Others
 and- strength error
 performance

CE : Aluminum foil electrolytic	0J : 6.3V	F : ±1%	HS : High stability type
CA : Aluminum solid electrolytic	1A : 10V	G : ±2%	BP : Non-polar type
CS : Tantalum electrolytic	1C : 16V	J : ±5%	HR : Ripple-resistant type
CQ : Film	1E : 25V	K : ±10%	DL : For change and discharge
CK : Ceramic	1V : 35V	M : ±20%	HF : For assuring high frequency
CC : Ceramic	1H : 50V	Z : +80%	U : UL part
CP : Oil	2A : 100V	-20%	C : CSA part
CM : Mica	2B : 125V	P : +100%	W : UL-CSA type
CF : Metallized	2C : 160V	-0%	F : Lead wire forming
CH : Metallized	2D : 200V	C : ±0.25pF	
	2E : 250V	D : ±0.5pF	
	2H : 500V	= : Others	
	2J : 630V		

*** Capacity (electrolyte only)**

2 2 2 ⇒ 2200µF
 Indicates number of zeros after effective number.
 2-digit effective number.

• Units: µF.

2 R 2 ⇒ 2.2µF
 1-digit effective number.
 2-digit effective number, decimal point indicated by R.

• Units: µF.

*** Capacity (except electrolyte)**

2 2 2 ⇒ 2200pF=0.0022µF
 (More than 2)—Indicates number of zeros after effective number.
 2-digit effective number.

• Units: pF.

2 2 1 ⇒ 220pF
 (0 or 1) — Indicates number of zeros after effective number.
 2-digit effective number.

• Units: pF.

• When the dielectric strength is indicated in AC, "AC" is included after the dielectric strength value.

PARTS LIST OF P.W.B. UNIT ASS'Y

1U-3498 MAIN UNIT ASS'Y

Ref. No.	Part No.	Part Name	Remarks	Q'ty	New
SEMICONDUCTORS GROUP					
IC201	262 3180 208	UPD784216AGC-203-8EU			
IC202	262 2986 005	93LC66			
IC203	263 1093 002	BA05ST			
IC205	263 0454 901	M51957BFP(TP1)			
IC301	262 1875 900	BU4066BCF-T1			*
IC302	262 3181 906	LC75342M			
IC303	262 2547 907	LC72720NM			
IC304,305	263 0615 902	BA15218F-DXE2			
IC401	262 3182 002	LC75725E			*
IC402	499 0301 006	RPM6938-V4			
IC501	265 0109 003	STK402-050			
IC601	269 0170 005	TOTX178			
IC602	263 0809 006	NJM7805FA(S)			
IC603	263 0801 004	NJM7812FA(S)			
IC604	263 0793 002	NJM7806FA(S)			
IC605	263 0809 006	NJM7805FA(S)			
IC606,607	268 0073 905	ICP-N15T			
TR209	269 0185 906	DTA115TKAT146			
TR211	269 0083 901	DTA114EKT96			
TR301	269 0066 902	DTC323TKT96			
TR303,304	269 0054 901	DTC144EKT96			
TR305	269 0083 901	DTA114EKT96			
TR306	269 0066 902	DTC323TKT96			
TR307	269 0082 902	DTC114EKT96			
TR308	269 0066 902	DTC323TKT96			
TR309	273 0426 907	2SC2412KLNT146			
TR310	269 0083 901	DTA114EKT96			
TR311,312	269 0066 902	DTC323TKT96			
TR313	269 0082 902	DTC114EKT96			
TR315	269 0066 902	DTC323TKT96			
TR317	273 0384 900	2SC2412KT96(S)			
TR401,402	269 0082 902	DTC114EKT96			
TR501	271 0309 905	2SA1037AKT146S			
TR502-504	273 0426 907	2SC2412KLNT146			
TR601	271 0309 905	2SA1037AKT146S			
TR602,603	273 0426 907	2SC2412KLNT146			
TR604	269 0160 905	DTC143ZSATP			
TR605	272 0025 907	2SB562(C)TF			
TR606,607	273 0426 907	2SC2412KLNT146			
TR611	269 0091 906	DTC143TKT96			
TR612	269 0083 901	DTA114EKT96			
TR613	269 0082 902	DTC114EKT96			
D301-303	276 0375 905	1N4148T77 (TAPE)			
D305,306	276 0375 905	1N4148T77 (TAPE)			
D601	276 0375 905	1N4148T77 (TAPE)			
D602,603	276 0772 003	1N4004			
D604-606	276 0375 905	1N4148T77 (TAPE)			
D607-610	276 0772 003	1N4004			
D611	276 0741 005	D3SBA60			
D612,613	276 0772 003	1N4004			

1U-3498 MAIN UNIT ASS'Y

	Ref. No.	Part No.	Part Name	Remarks	Q'ty	New
	D614	276 0375 905	1N4148T77 (TAPE)			
	D615,616	276 0772 003	1N4004			
	D617-619	276 0375 905	1N4148T77 (TAPE)			
	D621,622	276 0375 905	1N4148T77 (TAPE)			
	D623-626	276 0772 003	1N4004			
	ZD601,602	276 0760 963	MTZJ6.2B T77			
	ZD603	276 0760 950	MTZJ5.6B T77			
	ZD604	276 0762 932	MTZJ33B T77			
	LD401	393 9618 007	SLR-9336DS-91			
RESISTORS GROUP						
	R205	247 2011 942	RM73B--473JT			
	R207	247 2011 942	RM73B--473JT			
	R209-214	247 2009 909	RM73B--472JT (1608)			
	R216	247 2009 909	RM73B--472JT (1608)			
	R219	247 2009 909	RM73B--472JT (1608)			
	R221	247 2009 909	RM73B--472JT (1608)			
	R222	247 2007 943	RM73B--102JT			
	R224	247 2010 927	RM73B--153JT			
	R225	247 2011 900	RM73B--333JT			
	R226-228	247 2009 983	RM73B--103JT			
	R231	244 2055 941	RS14B3A331JNBST(S)			
	R234,235	247 2009 983	RM73B--103JT			
	R236	247 2007 943	RM73B--102JT			
	R237	247 2009 909	RM73B--472JT (1608)			
	R238	244 2055 941	RS14B3A331JNBST(S)			
	R239	247 2007 943	RM73B--102JT			
	R241-244	247 2018 903	RM73B--0R0KT			
	R245	247 2007 943	RM73B--102JT			
	R247	247 2009 909	RM73B--472JT (1608)			
	R250	247 2008 913	RM73B--202JT			
	R253,254	247 2011 942	RM73B--473JT			
	R255,256	247 2008 913	RM73B--202JT			
	R257	247 2006 960	RM73B--471JT			
	R258	247 2009 983	RM73B--103JT			
	R301,302	247 2013 982	RM73B--474JT			
	R303,304	247 2006 960	RM73B--471JT			
	R305,306	247 2013 982	RM73B--474JT			
	R307,308	247 2006 960	RM73B--471JT			
	R309,310	247 2013 982	RM73B--474JT			
	R311,312	247 2006 960	RM73B--471JT			
	R313,314	247 2013 982	RM73B--474JT			
	R315-317	247 2006 960	RM73B--471JT			
	R319,320	247 2012 925	RM73B--104JT			
	R321,322	247 2008 913	RM73B--202JT			
	R323-326	247 2009 983	RM73B--103JT			
	R327-329	247 2007 943	RM73B--102JT			
	R331	247 2010 969	RM73B--223JT			
	R332	247 2007 943	RM73B--102JT			
	R333,334	247 2010 969	RM73B--223JT			
	R335,336	247 2008 971	RM73B--362JT			
	R337	247 2009 954	RM73B--752JT			
	R338	247 2009 909	RM73B--472JT (1608)			
	R339,340	247 2012 925	RM73B--104JT			
	R341,342	247 2011 942	RM73B--473JT			
	R343,344	247 2008 913	RM73B--202JT			

1U-3498 MAIN UNIT ASS'Y

	Ref. No.	Part No.	Part Name	Remarks	Q'ty	New
	R345	247 2006 960	RM73B--471JT			
	R347,348	247 2007 943	RM73B--102JT			
	R349,350	247 2012 925	RM73B--104JT			
	R351,352	247 2007 969	RM73B--122JT			
	R353,354	247 2009 909	RM73B--472JT (1608)			
	R355,356	247 2011 942	RM73B--473JT			
	R357,358	247 2009 967	RM73B--822JT			
	R359,360	247 2007 985	RM73B--152JT			
	R361,362	247 2011 942	RM73B--473JT			
	R363-365	247 2009 909	RM73B--472JT (1608)			
	R368	247 2008 913	RM73B--202JT			
	R369	247 2009 909	RM73B--472JT (1608)			
	R371,372	247 2011 942	RM73B--473JT			
	R374	247 2009 983	RM73B--103JT			
	R376	247 2011 900	RM73B--333JT			
	R401	247 2006 944	RM73B--391JT			
	R402	247 2007 901	RM73B--681JT			
	R403	247 2006 915	RM73B--271JT			
	R404	247 2006 944	RM73B--391JT			
	R405	247 2005 961	RM73B--181JT			
	R406	247 2006 915	RM73B--271JT			
	R407	247 2005 945	RM73B--151JT			
	R408	247 2005 961	RM73B--181JT			
	R409	247 2005 987	RM73B--221JT			
	R410	247 2006 960	RM73B--471JT			
	R411	247 2005 945	RM73B--151JT			
	R414	247 2009 925	RM73B--562JT			
	R415	247 2009 909	RM73B--472JT (1608)			
	R416-419	247 2018 903	RM73B--0R0KT			
	R501,502	247 2007 943	RM73B--102JT			
	R503,504	247 2011 968	RM73B--563JT			
	R507,508	244 2051 987	RS14B3A4R7JNBST(S)			
⚠	R509,510	241 2313 901	RD14B2E101GFRST			
	R513,514	244 2051 987	RS14B3A4R7JNBST(S)			
	R515-517	247 2010 969	RM73B--223JT			
	R520	247 2009 938	RM73B--622JT			
	R521	247 2010 927	RM73B--153JT			
	R601	247 2009 983	RM73B--103JT			
	R602	247 2010 969	RM73B--223JT			
	R603	247 2009 983	RM73B--103JT			
	R604	247 2010 969	RM73B--223JT			
	R605	247 2009 983	RM73B--103JT			
	R606,607	247 2010 969	RM73B--223JT			
	R608	247 2008 926	RM73B--222JT			
	R609	247 2010 969	RM73B--223JT			
	R610	247 2007 943	RM73B--102JT			
	R611	247 2010 969	RM73B--223JT			
	R612	247 2011 942	RM73B--473JT			
	R613	247 2005 987	RM73B--221JT			
	R614-616	247 2005 903	RM73B--101JT			
	R617	247 2008 968	RM73B--332JT			
	R618	244 2050 933	RS14B3A181JNBST(S)			
	R619,620	247 2009 983	RM73B--103JT			
	R621	247 2008 968	RM73B--332JT			
	R622	247 2009 983	RM73B--103JT			
	R624	247 2011 942	RM73B--473JT			
	R625	244 2051 945	RS14B3A010JNBST(S)			
	R626	247 2009 909	RM73B--472JT (1608)			
	R627	247 2011 942	RM73B--473JT			
	R628	247 2007 943	RM73B--102JT			

1U-3498 MAIN UNIT ASS'Y

	Ref. No.	Part No.	Part Name	Remarks	Q'ty	New
	R921-923	247 2009 983	RM73B--103JT			
CAPACITORS GROUP						
	C201	254 4538 900	CE04W1C100MT SMG/RE3			
	C202,203	257 0511 904	CK73F1H103ZT			
	C204	254 4524 943	CE04W1H010MT SMG/RE3			
	C208	257 0512 903	CK73F1E104ZT			
	C209	254 4524 956	CE04W1H2R2MT SMG/RE3			
	C210	254 4538 939	CE04W1C470MT SMG/RE3			
	C211	257 0512 903	CK73F1E104ZT			
	C212	257 0501 901	CK73B1H103KT (1608)			
	C216	257 0512 903	CK73F1E104ZT			
	C218,219	257 0506 951	CC73CH1H101JT			
	C220	257 0512 903	CK73F1E104ZT			
	C301,302	257 0508 917	CC73CH1H471JT			
	C303,304	254 4524 972	CE04W1H4R7MT SMG/RE3			
	C305,306	257 0508 917	CC73CH1H471JT			
	C307,308	254 4524 972	CE04W1H4R7MT SMG/RE3			
	C309,310	257 0508 917	CC73CH1H471JT			
	C311,312	254 4524 972	CE04W1H4R7MT SMG/RE3			
	C313,314	257 0508 917	CC73CH1H471JT			
	C315,316	254 4524 972	CE04W1H4R7MT SMG/RE3			
	C317	257 0509 929	CK73B1H102KT			
	C319,320	254 4524 972	CE04W1H4R7MT SMG/RE3			
	C321-323	257 0511 904	CK73F1H103ZT			
	C324	254 4524 901	CE04W1H0R1MT SMG/RE3			
	C325-330	254 4524 972	CE04W1H4R7MT SMG/RE3			
	C331-334	256 1058 971	CF93A1H104JT (JL)			
	C335	257 0509 929	CK73B1H102KT			
	C337,338	257 0510 905	CK73B1H272KT			
	C339	254 4538 913	CE04W1C220MT SMG/RE3			
	C340	257 0501 901	CK73B1H103KT (1608)			
	C341-343	254 4538 900	CE04W1C100MT SMG/RE3			
	C344	254 4536 915	CE04W1A470MT SMG/RE3			
	C345,346	257 0511 904	CK73F1H103ZT			
	C347	254 4538 900	CE04W1C100MT SMG/RE3			
	C348	254 4524 972	CE04W1H4R7MT SMG/RE3			
	C349,350	257 0504 908	CC73CH1H220JT			
	C351	257 0507 976	CC73CH1H331JT			
	C352	257 0508 933	CC73CH1H561JT			
	C353,354	254 4524 972	CE04W1H4R7MT SMG/RE3			
	C355,356	254 4524 972	CE04W1H4R7MT SMG/RE3	NICHICHEMI		
	C357-359	254 4538 939	CE04W1C470MT SMG/RE3			
	C360	254 4524 901	CE04W1H0R1MT SMG/RE3			
	C361,362	254 4538 900	CE04W1C100MT SMG/RE3			
	C363,364	254 4524 972	CE04W1H4R7MT SMG/RE3			
	C365	254 4538 939	CE04W1C470MT SMG/RE3			
	C366	254 4538 900	CE04W1C100MT SMG/RE3			
	C367	254 4524 901	CE04W1H0R1MT SMG/RE3			
	C368	257 0511 904	CK73F1H103ZT			
	C404	254 4192 922	CE04W1A470MT (SRA)			
	C405	257 0511 904	CK73F1H103ZT			
	C406	254 4192 922	CE04W1A470MT (SRA)			
	C407	257 0504 908	CC73CH1H220JT			
	C408	257 0511 904	CK73F1H103ZT			
	C409,410	257 0509 929	CK73B1H102KT			
	C411	253 1180 921	CK45B1H102KT(DD-3)			
	C501,502	254 3056 920	CE04D1H2R2MBPT (SME)			
	C503,504	254 4525 900	CE04W1H330MT SMG/RE3			

1U-3498 MAIN UNIT ASS'Y

	Ref. No.	Part No.	Part Name	Remarks	Q'ty	New
	C505,506	257 0508 917	CC73CH1H471JT			
	C509,510	254 4525 735	CE04W1H221MC SMG/RE3			
	C511,512	256 1058 971	CF93A1H104JT (JL)			
	C513,514	254 4524 985	CE04W1H100MT SMG/RE3			
	C515,516	257 0502 955	CC73CH1H3R0CT			
	C517	254 4536 944	CE04W1A331MT SMG/RE3			
	C518,519	257 0507 934	CC73CH1H221JT			
	C599	254 3056 917	CE04D1H010MBPT (SME)			
	C601	257 0509 929	CK73B1H102KT			
	C602	254 4536 915	CE04W1A470MT SMG/RE3			
	C603	257 0511 904	CK73F1H103ZT			
	C604	257 0509 929	CK73B1H102KT			
	C605	257 0511 904	CK73F1H103ZT			
	C606	254 4538 900	CE04W1C100MT SMG/RE3			
	C607	257 0511 904	CK73F1H103ZT			
	C608	254 4524 943	CE04W1H010MT SMG/RE3			
	C609	254 4538 900	CE04W1C100MT SMG/RE3			
	C610	257 0511 904	CK73F1H103ZT			
	C611	254 4524 943	CE04W1H010MT SMG/RE3			
	C612	254 4523 724	CE04W1V472MC SMG/RE3			
	C613	257 0511 904	CK73F1H103ZT			
	C614	253 8026 703	CK45E2EAC472MC			
	C615	257 0511 904	CK73F1H103ZT			
	C616	254 4541 939	CE04W1E470MT SMG/RE3			
	C617,618	254 4523 724	CE04W1V472MC SMG/RE3			
	C619,620	257 0511 904	CK73F1H103ZT			
	C621	254 4538 900	CE04W1C100MT SMG/RE3			
	C622	257 0511 904	CK73F1H103ZT			
	C623	254 4524 943	CE04W1H010MT SMG/RE3			
	C624,625	257 0511 904	CK73F1H103ZT			
	C626	254 4524 985	CE04W1H100MT SMG/RE3			
	C627	254 4396 906	CE04W1J101MT(SMG)			
	C628	257 0511 904	CK73F1H103ZT			
	C629	257 0501 901	CK73B1H103KT (1608)			
	C630	254 4538 900	CE04W1C100MT SMG/RE3			
	C631	257 0511 904	CK73F1H103ZT			
	C632	254 4524 943	CE04W1H010MT SMG/RE3			
	C633	254 4403 721	CE04W1E222MC (SMG)			
	C634,635	257 0511 904	CK73F1H103ZT			
	C640	257 0511 904	CK73F1H103ZT			
	C641	257 0512 903	CK73F1E104ZT			
	C655,656	254 4525 900	CE04W1H330MT SMG/RE3			
	C657	254 4537 707	CE04W1A102MC SMG/RE3			
	C701,702	257 0509 929	CK73B1H102KT			
	C703,704	255 1265 936	CQ93M1H103JT(B)			
OTHER PARTS GROUP						
	AS601,602	417 0476 049	RADIATOR			
	CX31	205 0653 036	3P VH CON.BASE			
	CX32	205 0581 056	2P VH CONNECTOR BASE			
	CX33	205 0581 001	2P VH CONNECTOR BASE			
	CX34	205 0355 033	3P KR CON BASE(L)			
	CX37	205 0355 033	3P KR CON BASE(L)			
	CX38	205 0323 036	3P CONNE.BASE(BLK)			
	CX41	205 0355 046	4P KR CON BASE(L)			
	CX42	205 0343 045	4P CONN.BASE(KR-PH)			
	CX43	205 0355 046	4P KR CON BASE(L)			
	CX51	205 0449 059	5P VH CONNECTOR BASE			
	CX52	205 0190 052	5P NH CONNECTOR BASE			

1U-3498 MAIN UNIT ASS'Y

	Ref. No.	Part No.	Part Name	Remarks	Q'ty	New
	CX72	205 0535 086	7P CONN.BASE			
	CX81	205 0355 088	8P KR CON BASE(L)			
	CX121	205 0375 026	12P CONN.BASE(KR-PH)			
	CX143	205 0708 033	14P CONN.SOCKET			
	CX151	205 0480 050	15P KR CON BASE(L)			
	CX153	205 0767 058	15P CON BASE			*
	CX171	205 1006 080	17P FFC BASE(P=1)			
	CX181	205 1050 052	18P FFC BASE(SIDE)			*
	CX251	205 1050 010	25P FFC BASE (9603F)			
	CY38	205 0406 034	3P CON BASE(KR-PH)			
	CY41	203 6590 016	4P PH-SAN CONN CORD			*
	CY42	203 6592 001	4P PH-SAN CON CORD			*
	CY51	203 8535 011	5P VH-SAN CON CORD			*
	CY72	205 0536 085	7P CONN.SOCKET			
	CY81	204 2933 010	8P PH-SAN CON CORD			*
	CY121	205 0480 021	12P KR CON BASE(L)			
	CY143	205 0707 034	14P CONN.BASE			
	CY151	204 6753 005	15P PH-SAN CON CORD			*
	CY152	205 0736 076	15P FFC CON.BASE			
	CY153	205 0766 059	15P CON SOCKET			*
	CY171	205 1006 080	17P FFC BASE(P=1)			
	CY181	205 1050 052	18P FFC BASE(SIDE)			*
⚠	F601	206 1074 073	FUSE (0.5A)			
⚠	F602	206 1075 043	FUSE(2.5A)			
	FF601,602	202 0040 909	FUSE CLIP (TAPE)			
	FH601,602	202 0040 909	FUSE CLIP (TAPE)			
	FL401	393 8068 001	FL TUBE(HNA-11SS47T)			
	JK301,302	204 8635 024	4P PIN JACK (C-GND)			
	JK303	204 8642 004	1P P1N JACK BK			
	JK401	204 8636 007	MINI JACK (ST.SW)			
	JK408	205 1261 003	SP TERMINAL(R)			*
	JK601,602	204 8637 006	MINI JACK (STEREO)			
⚠	JK604	203 3961 004	1P AC OUTLET(E2)			
	L501,502	235 0104 010	INDUCTOR(3UH)			*
	RL601	214 0206 005	RELAY(PCI212DM)			
	RL602	214 0224 003	RELAY(0JT-SS-109LM)			*
	RL603	214 0203 008	RELAY(NA12W-K)			
	SW402,403	212 0467 000	TACT SW(H=5)			
	SW405-407	212 0467 000	TACT SW(H=5)			
	SW409-412	212 0467 000	TACT SW(H=5)			
	SW413	212 0461 006	ROTARY ENCODER(V)			
⚠	T601	233 6383 004	POWER TRANS(SUB/E2)			
	W705	203 0322 057	1P CONTACT ASS'Y			
	W717	203 0541 058	1P SIN CORD ASS'Y			
	W719	001 0026 045	WIRE CORD			
	X201	399 0532 902	CST12.5MTW-TF01			
	X301	399 0178 007	X-TAL(4.332MHZ)			
		125 9002 007	UL TUBE (L=10)			
					2	

1U-3498 MAIN UNIT ASS'Y

	Ref. No.	Part No.	Part Name	Remarks	Q'ty	New
		415 0908 003	SHIELD PLATE		1	*
		449 0172 007	SENSOR HOLDER		1	
		461 1110 000	FL SPACER(D-SIDE)		2	
		471 3304 015	3X8 CBS-Z		2	

1U-3507 CD PWB UNIT ASS'Y

	Ref. No.	Part No.	Part Name	Remarks	New
SEMICONDUCTORS GROUP					
	IC801	263 1091 907	LA6559		
	IC802	263 1090 005	LA9241M		
	IC803	262 2903 004	LC78625E		
	IC804	263 0934 900	BA4510F-E2		
	IC805	263 0994 908	BA6287F-E2		
	TR801-804	269 0054 901	DTC144EKT96		
	TR805	269 0085 909	DTC144TKT96		
	TR806	271 0309 905	2SA1037AKT146S		
	TR807	269 0085 909	DTC144TKT96		
	TR810	272 0025 907	2SB562(C)TF		
	TR811	269 0082 902	DTC114EKT96		
RESISTORS GROUP					
	R801	247 2011 900	RM73B--333JT		
	R802-805	247 2010 927	RM73B--153JT		
	R806	247 2011 900	RM73B--333JT		
	R807	247 2004 920	RM73B--470JT		
	R808	247 2018 903	RM73B--0R0KT		
	R809	247 2004 920	RM73B--470JT		
	R810	247 2012 925	RM73B--104JT		
	R811,812	247 2004 920	RM73B--470JT		
	R813	247 2010 969	RM73B--223JT		
	R814	247 2010 972	RM73B--243JT		
	R815	247 2009 925	RM73B--562JT		
	R816	247 2008 926	RM73B--222JT		
	R817	247 2004 920	RM73B--470JT		
	R818	247 2011 984	RM73B--683JT		
	R819	247 2010 914	RM73B--133JT		
	R820	247 2010 956	RM73B--203JT		
	R821	247 2009 925	RM73B--562JT		
	R822	247 2009 983	RM73B--103JT		
	R823	247 2007 943	RM73B--102JT		
	R824,825	247 2010 927	RM73B--153JT		
	R826	247 2010 972	RM73B--243JT		
	R827-829	247 2010 969	RM73B--223JT		
	R830	247 2018 903	RM73B--0R0KT		
	R831	247 2013 908	RM73B--224JT		
	R832	247 2010 956	RM73B--203JT		
	R833	247 2010 927	RM73B--153JT		
	R834	247 2006 999	RM73B--621JT		
	R835	247 2007 943	RM73B--102JT		
	R836	247 2011 900	RM73B--333JT		
	R837	247 2010 969	RM73B--223JT		
	R838	247 2018 903	RM73B--0R0KT		
	R839	247 2011 955	RM73B--513JT		
	R840	247 2012 983	RM73B--184JT		
	R841	247 2011 900	RM73B--333JT		
	R842	247 2010 943	RM73B--183JT		
	R843	247 2008 926	RM73B--222JT		
	R844	247 2010 985	RM73B--273JT		
	R845	247 2010 998	RM73B--303JT		
	R846	247 2010 985	RM73B--273JT		
	R847	247 2011 942	RM73B--473JT		
	R848,849	247 2009 983	RM73B--103JT		
	R850	247 2018 903	RM73B--0R0KT		
	R851	247 2011 971	RM73B--623JT		

1U-3507 CD PWB UNIT ASS'Y

	Ref. No.	Part No.	Part Name	Remarks	New
	R852	247 2010 985	RM73B--273JT		
	R853	247 2010 972	RM73B--243JT		
	R854	247 2002 964	RM73B--100JT		
	R855	247 2004 991	RM73B--910JT		
	R856	247 2011 942	RM73B--473JT		
	R857	247 2004 991	RM73B--910JT		
	R858	247 2010 943	RM73B--183JT		
	R859	247 2011 900	RM73B--333JT		
	R860	247 2008 926	RM73B--222JT		
	R861	247 2010 985	RM73B--273JT		
	R862	247 2010 998	RM73B--303JT		
	R863	247 2006 931	RM73B--361JT		
	R864,865	247 2018 903	RM73B--0R0KT		
	R866	247 2011 913	RM73B--363JT		
	R867	247 2012 954	RM73B--134JT		
	R868	247 2011 984	RM73B--683JT		
	R869	247 2008 926	RM73B--222JT		
	R870	247 2010 901	RM73B--123JT		
	R871	247 2008 968	RM73B--332JT		
	R872	247 2009 909	RM73B--472JT (1608)		
	R873	247 2013 924	RM73B--274JT		
	R874,875	247 2012 996	RM73B--204JT		
	R876	247 2011 955	RM73B--513JT		
	R877	247 2010 969	RM73B--223JT		
	R878	247 2009 983	RM73B--103JT		
	R879	247 2011 926	RM73B--393JT		
	R881	247 2009 983	RM73B--103JT		
	R882	247 2018 903	RM73B--0R0KT		
	R883	247 2015 906	RM73B--155KT		
	R884	247 2006 902	RM73B--331JT (1608)		
	R885	247 2011 900	RM73B--333JT		
	R886	247 2007 901	RM73B--681JT		
	R887	247 2011 900	RM73B--333JT		
	R888	247 2007 969	RM73B--122JT		
	R890	247 2018 903	RM73B--0R0KT		
	R891	247 2003 947	RM73B--220JT		
	R893	247 2008 913	RM73B--202JT		
	R894,895	247 2018 903	RM73B--0R0KT		
	R896	247 2003 947	RM73B--220JT		
	R897-900	247 2009 967	RM73B--822JT		
	R901	247 2004 920	RM73B--470JT		
	R903-906	247 2009 938	RM73B--622JT		
	R907-910	247 2010 914	RM73B--133JT		
	R911,912	247 2008 913	RM73B--202JT		
	R913,914	247 2011 942	RM73B--473JT		
	R915,916	247 2007 943	RM73B--102JT		
	R918	247 2018 903	RM73B--0R0KT		
	R921	247 2018 903	RM73B--0R0KT		
	R923	244 2052 928	RS14B3A470JNBST(S)		
	R923	247 2009 983	RM73B--103JT		
	R926	247 2009 983	RM73B--103JT		
CAPACITORS GROUP					
	C801	257 0512 903	CK73F1E104ZT		
	C804-809	257 0512 903	CK73F1E104ZT		
	C810	254 4537 707	CE04W1A102MC SMG/RE3		
	C811	257 0516 925	CK73B1E333KT		
	C812	257 0507 976	CC73CH1H331JT		
	C813,814	257 0512 903	CK73F1E104ZT		
	C815	254 4192 935	CE04W1A101MT (SRA)		

1U-3507 CD PWB UNIT ASS'Y

	Ref. No.	Part No.	Part Name	Remarks	New
	C816	254 4196 928	CE04W1HR33MT (SRA)		
	C817	257 0501 927	CK73B1H153KT		
	C818	257 0501 901	CK73B1H103KT (1608)		
	C819	257 0517 908	CK73B1C473KT		
	C820	257 0516 954	CK73B1E104KT		
	C821	257 0506 993	CC73CH1H151JT		
	C822	254 4192 935	CE04W1A101MT (SRA)		
	C823	257 0517 908	CK73B1C473KT		
	C824	257 0501 901	CK73B1H103KT (1608)		
	C825,826	257 0517 908	CK73B1C473KT		
	C827	257 0512 903	CK73F1E104ZT		
	C829	254 4193 947	CE04W1C101MT (SRA)		
	C831,832	257 0512 903	CK73F1E104ZT		
	C833-835	257 0501 901	CK73B1H103KT (1608)		
	C837	257 0501 901	CK73B1H103KT (1608)		
	C838	257 0509 929	CK73B1H102KT		
	C840	257 0512 903	CK73F1E104ZT		
	C841	254 4193 934	CE04W1C470MT (SRA)		
	C842	257 0509 929	CK73B1H102KT		
	C843	257 0512 903	CK73F1E104ZT		
	C844	257 0507 934	CC73CH1H221JT		
	C845	257 0509 929	CK73B1H102KT		
	C846	254 4192 948	CE04W1A221MT(SRA)		
	C847	257 0514 901	CK73F1C334ZT		
	C848	257 0501 901	CK73B1H103KT (1608)		
	C849	257 0512 903	CK73F1E104ZT		
	C850	257 0517 908	CK73B1C473KT		
	C851	254 4538 942	CE04W1C101MT SMG/RE3		
	C852	257 0501 901	CK73B1H103KT (1608)		
	C853	254 3056 917	CE04D1H010MBPT (SME)		
	C854	257 0510 918	CK73B1H332KT		
	C855	257 0506 951	CC73CH1H101JT		
	C857	254 4538 900	CE04W1C100MT SMG/RE3		
	C858-860	257 0512 903	CK73F1E104ZT		
	C861	254 4193 947	CE04W1C101MT (SRA)		
	C862	254 4192 935	CE04W1A101MT (SRA)		
	C863	254 3056 917	CE04D1H010MBPT (SME)		
	C864	257 0510 918	CK73B1H332KT		
	C865	254 4538 939	CE04W1C470MT SMG/RE3		
	C867-869	257 0506 951	CC73CH1H101JT		
	C870	254 4524 972	CE04W1H4R7MT SMG/RE3		
	C872	257 0516 954	CK73B1E104KT		
	C873	257 0509 929	CK73B1H102KT		
	C874	257 0502 955	CC73CH1H3R0CT		
	C876	257 0503 941	CC73CH1H120JT		
	C877	257 0501 901	CK73B1H103KT (1608)		
	C878	254 4524 972	CE04W1H4R7MT SMG/RE3		
	C879	257 0517 908	CK73B1C473KT		
	C880	257 0516 954	CK73B1E104KT		
	C881	257 0506 951	CC73CH1H101JT		
	C882	257 0512 903	CK73F1E104ZT		
	C883,884	254 4536 928	CE04W1A101MT SMG/RE3		
	C885,886	257 0512 903	CK73F1E104ZT		
	C887,888	257 0503 967	CC73CH1H150JT		
	C889,890	257 0506 951	CC73CH1H101JT		
	C891	257 0512 903	CK73F1E104ZT		
	C893	257 0511 917	CK73F1H223ZT		
	C894	257 0512 903	CK73F1E104ZT		
	C895,896	257 0507 992	CC73CH1H391JT		
	C897,898	257 0507 950	CC73CH1H271JT		

1U-3507 CD PWB UNIT ASS'Y

	Ref. No.	Part No.	Part Name	Remarks	New
	C899	257 0512 903	CK73F1E104ZT		
	C901,902	257 0507 950	CC73CH1H271JT		
	C903,904	254 4541 913	CE04W1E220MT SMG/RE3		
	C905,906	257 0509 929	CK73B1H102KT		
	C908	254 4536 915	CE04W1A470MT SMG/RE3		
	C909	254 4538 942	CE04W1C101MT SMG/RE3		
	C910	257 0512 903	CK73F1E104ZT		
	C912	257 0501 901	CK73B1H103KT (1608)		
	C913	254 4194 917	CE04W1E100MT (SRA)		
	C915	254 4538 900	CE04W1C100MT SMG/RE3		
	C918	257 0511 904	CK73F1H103ZT		
	C923	254 4536 931	CE04W1A221MT SMG/RE3		
OTHER PARTS GROUP					
	CX52	205 0355 059	5P KR CON BASE(L)		
	CX61	205 0355 062	6P KR CON BASE(L)		
	CX162	205 0892 033	16P FFC BASE (P=1)		
	CX251	205 1050 010	25P FFC BASE (9603F)		
	CY34	205 0355 033	3P KR CON BASE(L)		
	FB801-810	235 0130 903	CHIP EMIFIL(11A121)		
	W801	203 0301 052	1P CONTACT ASS		
	X801	399 0165 007	X'TAL (16.9344)	REVER	

Countermeasure for E2 model 1~5000, EK model 1~70000.

1U-3529 MT P.W.B. UNIT ASS'Y

	Ref. No.	Part No.	Part Name	Remarks	New
	IC101	262 3175 909	74VHC00MTCX		
	IC102	262 3176 908	74VHC74MTCX		
	D101,102	276 0375 905	1N4148T77 (TAPE)		
	TR101	269 0083 901	DTA114EKT96		
	C101	257 0512 903	CK73F1E104ZT		
	R102	247 2011 942	RM37B-473JT		
	R103	247 2009 983	RM37B-103JT		
	CX082	205 0343 087	8P CON.BASE (KR-PH)		
	CX082	204 2835 011	8P PH CONN CORD		
		222 3529 007	P.W.BOARD		

PARTS LIST OF EXPLODED VIEW

Note: The symbols in the column "Remarks" indicate the following destinations.

E2: Europe model

EK: U.K. model

	Ref. No	Part No	Part Name	Remarks	Q'ty	NEW
	1	1U-3498	MAIN PWB UNIT		1	
	1-1		POWER UNIT			
	1-2		AMP1 UNIT			
	1-3		AMP2 UNIT			
	1-4		DISPLAY UNIT			
	1-5		SPEAKER UNIT			
	1-7		I/O UNIT			
	1-8		U-CON UNIT			
	1-9		JUNCTION UNIT			
	1-6	1U-3507	CD PWB UNIT		1	
	2	144 2820 106	FRONT PANEL		1	*
	3	146 2300 208	INNER PANEL		1	*
	4	143 1161 106	WINDOW		1	*
	5	113 1947 109	KNOB (L) 3P		1	*
	6	113 1948 001	KNOB(S)3P		1	*
	7	113 1949 000	KNOB(S)2P		1	*
	8	143 1086 003	REMOCON FILTER		1	
	9	113 1955 007	POWER KNOB ASS'Y		1	*
	10	112 0856 104	VOLUME KNOB ASS'Y		1	*
	11	146 2298 006	LOADER PANEL(UD)		1	*
	13	411 1940 411	MAIN CHASSIS		1	*
	14	104 0317 008	FOOT		4	
	15	461 1066 002	FELT		4	
	16	417 0596 013	HEAT SINK		1	*
	17	415 0908 003	SHIELD PLATE		1	*
	18	412 4621 002	MECHA HOLDER		1	
	19	337 0100 006	CD MECHA(CD11FTA3N)		1	
	20	105 1425 206	REAR PLATE (UD)		1	*
	21	412 4622 001	PCB SUPPORT(A)		1	
	22	102 0633 139	TOP COVER		1	*
⚠	23	233 6441 001	POWER TRANS(E2)		1	*
⚠	24	206 2089 106	AC CORD W/CON.E2	For E2	1	
⚠		206 2128 009	AC CORD W/CON EK	For EK		
	25	445 0056 008	CORD BUSH		1	
	26	216 0108 002	TUNER PACK (TFCE1E5)		1	
	27	443 9015 002	P.W. SPACER		3	
	28	412 2814 002	CARD SPACER (L=8)		2	
	29	393 8068 001	FL TUBE(HNA-11SS47T)		1	
	30	449 0172 007	SENSOR HOLDER		1	
	31	415 0844 002	PVC SHEET		1	
	33	414 0982 000	PARTITION SHEET		1	*
	35	415 0906 102	SAFETY COVER		1	*
	36	441 1976 004	SPACER		1	*
	37	412 4839 001	EARTH PLATE(H/P)		1	
	38	441 1977 003	WASHER		1	*
	40	131 0156 106	DENON BADGE		1	
	42	412 5014 100	TRANS BRACKET		1	*
	43	412 5012 005	PCB SUPPORT BRACKET		1	*
	44	445 0048 016	CORD HOLDER (L50)		2	
	45	009 0241 028	16P FFC CABLE	CX162	1	*
	46	009 0207 020	15P FFC(1.25)	CY152	1	*
	47	415 0911 003	SAFTY SHEET		1	
*		143 1085 004	LENS		1	
*		415 0585 015	UL TUBE(16) BK L=30		1	
*		445 8004 007	WIRE CLAMPER		5	
*		513 3673 008	LASER PICK LABEL		1	
*		513 3857 002	E2 LASER CAUTION (E)		1	
*		513 3632 007	CAUTION LABEL		1	

	Ref. No	Part No	Part Name	Remarks	Q'ty	NEW
*		513 3901 000	LASER CAUTION LABEL		1	
*		203 4804 034	3P PH-PH SHIELD WIRE	CX34	1	
*		203 8533 000	5P PH-PH CON.CORD	CX52	1	
*		204 0567 006	6P PH-PH CON.CORD	CX61	1	
*		009 0241 015	17P FFC CABLE	CX171	1	*
*		009 0207 017	18P FFC(1.25)	CX181	1	*
*		009 0027 048	25P FFC CORD	CX251	1	
*		204 6347 000	12P PH-PH CON. CORD	CY121	1	*
*		001 0144 037	VINYL WIRE	W720	1	
	SCREWS					
	101	473 7015 005	3X6 CBTS(S)-B		17	
	102	473 7002 005	3X6 CBTS(S)-Z		10	
	103	473 7500 044	3X8 CBTS (P)-B		28	
	105	473 7501 014	3X14 CBTS (P)-Z		4	
	107	473 7005 057	3X25 CBTS (S)-Z		2	
	108	473 8079 024	SPECIAL SCREW		2	
	109	473 7004 016	4X6 CBTS (S)-Z		8	
	110	477 0263 018	3P.SWELLING SCREW		2	
	112	477 0096 010	PUSH RIVET		3	

EXPLODED VIEW OF CD MECHANISM UNIT (CD11FTA3N)

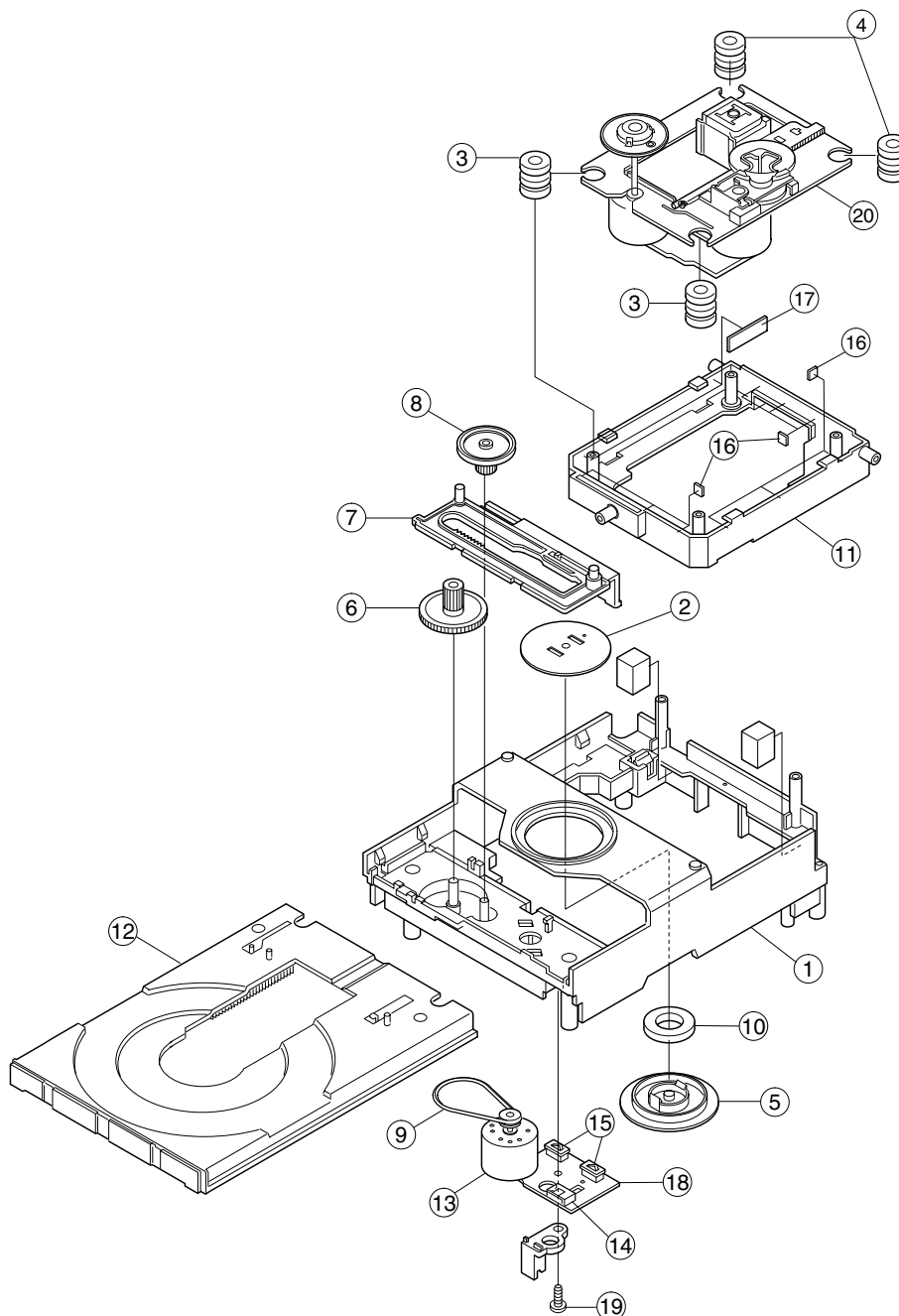

PARTS LIST OF CD MECHANISM UNIT

Ref. No.	Part No.	Part Name	Remarks	Q'ty	Ref. No.	Part No.	Part Name	Remarks	Q'ty
1	964 0009 006	Frame chassis		1	11	964 0010 008	Mecha lifter		1
2	964 0009 103	Magnet plate		1	12	964 0010 105	Loading table		1
3	964 0009 200	Rubber cushion		2	13	964 0010 901	Loading motor		1
4	964 0009 307	Rubber cushion		2	14	964 0010 202	5P Plug		1
5	964 0009 404	Magnet holder		1	15	964 0010 309	Push switch 2-1		2
6	964 0009 501	Drive gear		1	16	964 0010 406	Cushion		9
7	964 0009 608	Slide gear		1	17	964 0010 503	Cushion		2
8	964 0009 705	Pulley gear		1	18	964 0010 600	Motor P.W.B.		2
9	964 0009 802	Square belt		1	19	964 0010 707	Screw 3 8 SCR S-TPG BIN		1
10	964 0009 909	Magnet		1	20	964 0011 007	Mecha DA11T3CN		1

PACKING VIEW

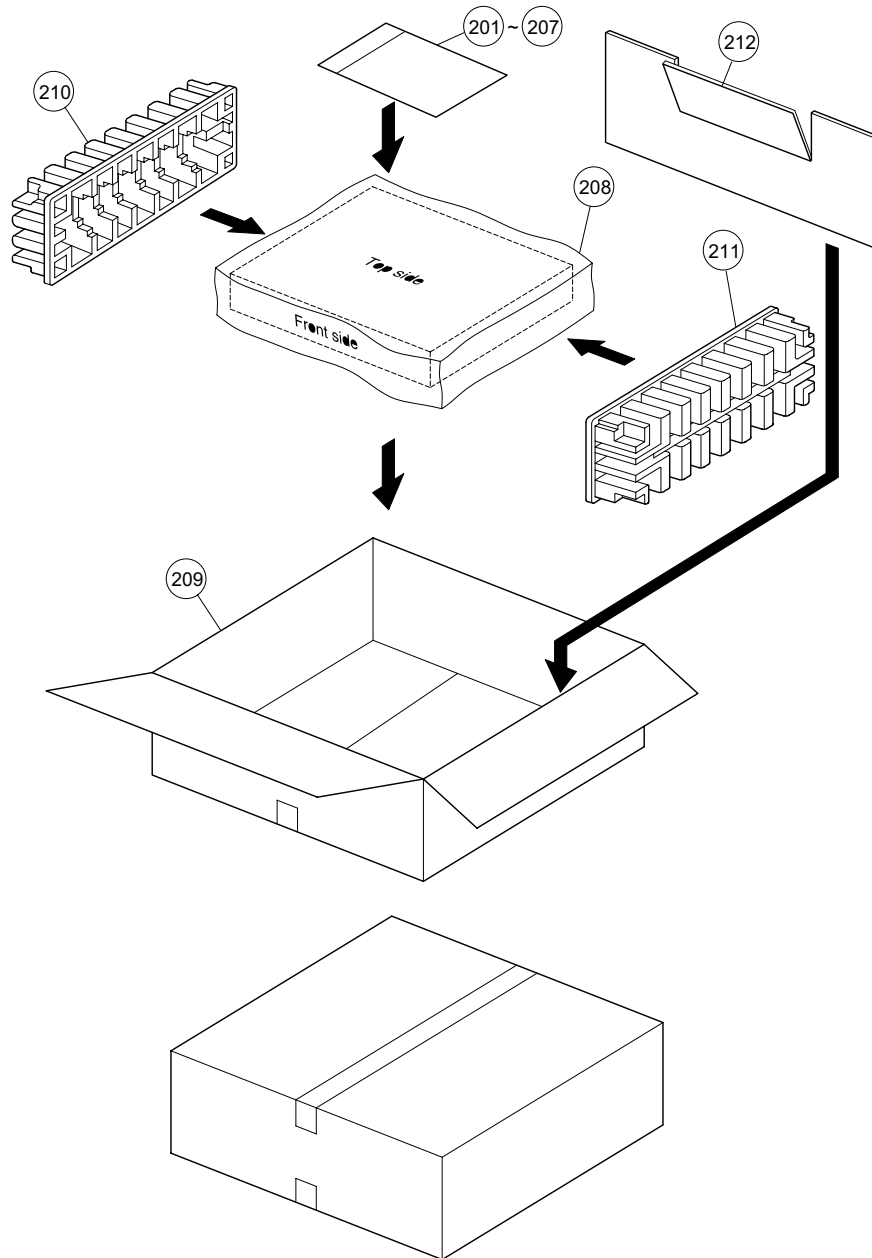

PACKING LIST OF PACKING & ACCESSORIES

Note: The symbols in the column "Remarks" indicate the following destinations.

E2: Europe model EK: U.K. model

	Ref. No.	Part No.	Part Name	Remarks	Q'ty	NEW
	201	505 0038 030	POLY COVER		1	
	202	511 3982 007	INST MANUAL		1	*
	203	515 0921 102	S.S.LIST(EX)		1	
	204	-	BATTERY (UM-4) ASS		1	
	205	399 0855 003	REMOCON (RC-933)		1	
	206	231 0922 009	LOOP ANTENNA		1	
	207	395 0026 005	FM ANT. WIRE		1	
	208	-	CONT.CARD(L)		1	
	209	501 2231 105	CARTON CASE		1	*
	210	503 1451 005	CUSHION(L)		1	*
	211	503 1452 004	CUSHION(R)		1	*
	212	502 1074 007	CUSHION BOARD (A)	For EK	1	*
*	213	517 1471 000	E2 POS LABEL	For E2	1	*
*		517 1472 009	EK POS LABEL	For EK	2	*
*	214	513 1642 002	NO. SHEET		1	
*	215	505 0358 008	POLY COVER	For EK	1	

WIRING

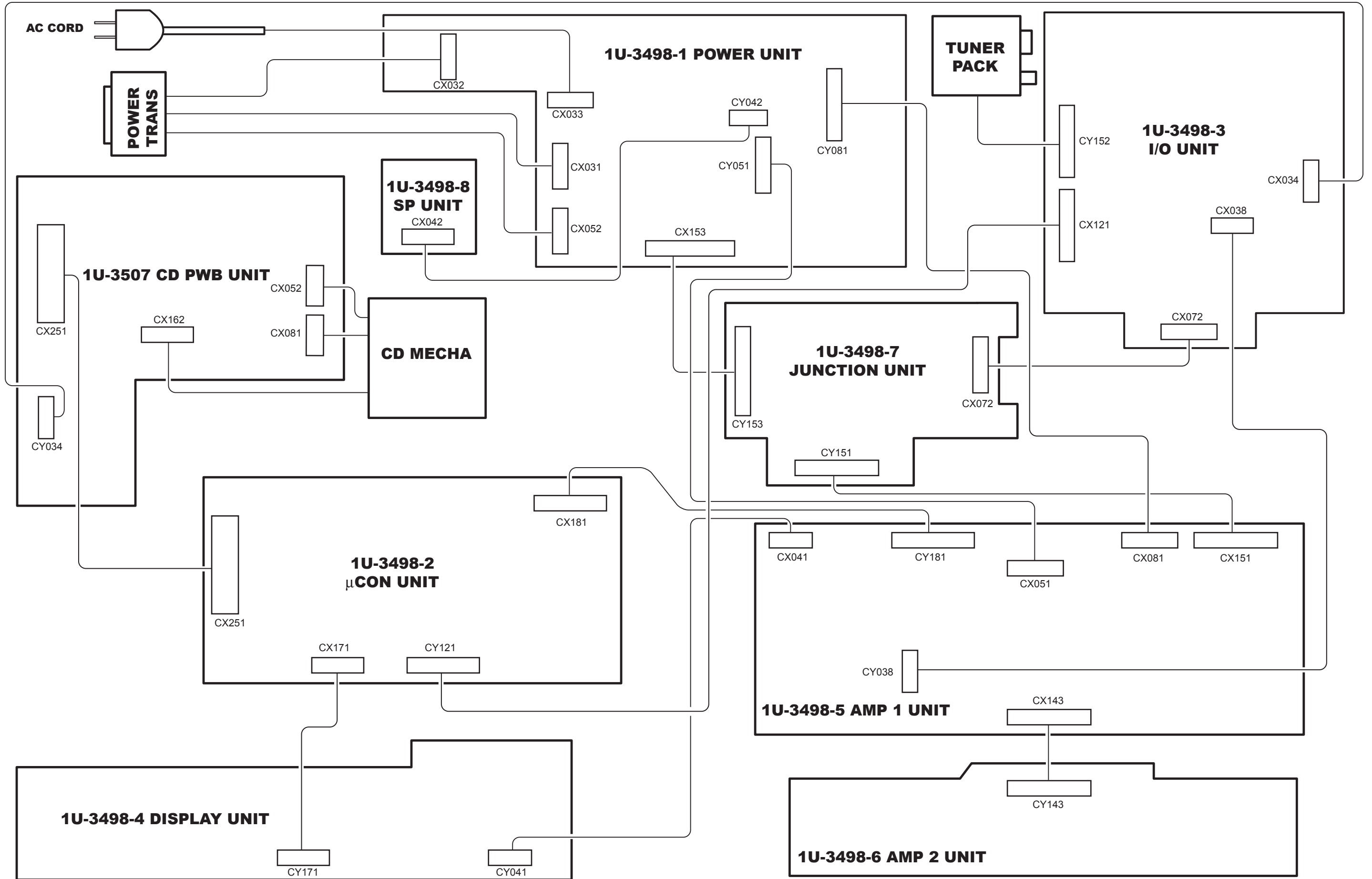

NOTE FOR SCHEMATIC DIAGRAM

WARNING:

Parts marked with this symbol  have critical characteristics.
Use ONLY replacement parts recommended by the manufacturer.

CAUTION:

Before returning the unit to the customer, make sure you make either (1) a leakage current check or (2) a line to chassis resistance check. If the leakage current exceeds 0.5 milliamps, or if the resistance from chassis to either side of the power cord is less than 460 kohms, the unit is defective.

WARNING:

DO NOT return the unit to the customer until the problem is located and corrected.

NOTICE

ALL RESISTANCE VALUES IN OHM. k=1,000 OHM

M=1,000,000 OHM

ALL CAPACITANCE VALUES IN MICRO FARAD.

P=MICRO-MICRO FARAD

EACH VOLTAGE AND CURRENT ARE MEASURED AT NO SIGNAL INPUT CONDITION.

CIRCUIT AND PARTS ARE SUBJECT TO CHANGE WITHOUT PRIOR NOTICE.

配線図について

 印の部品は安全を維持するために重要な部品です。従って交換時は必ず指定の部品を使用してください。

- 注) 1. 指定なき抵抗値は Ω 、 $k\Omega$ 、 M は $M\Omega$ を示す。
2. 指定なきコンデンサーの値は μF 、 p は pF を示す。
3. 各部の電圧は無信号の値を示す。
4. この配線図は基本配線図です。改良等のため変更することがありますのでご了承ください。

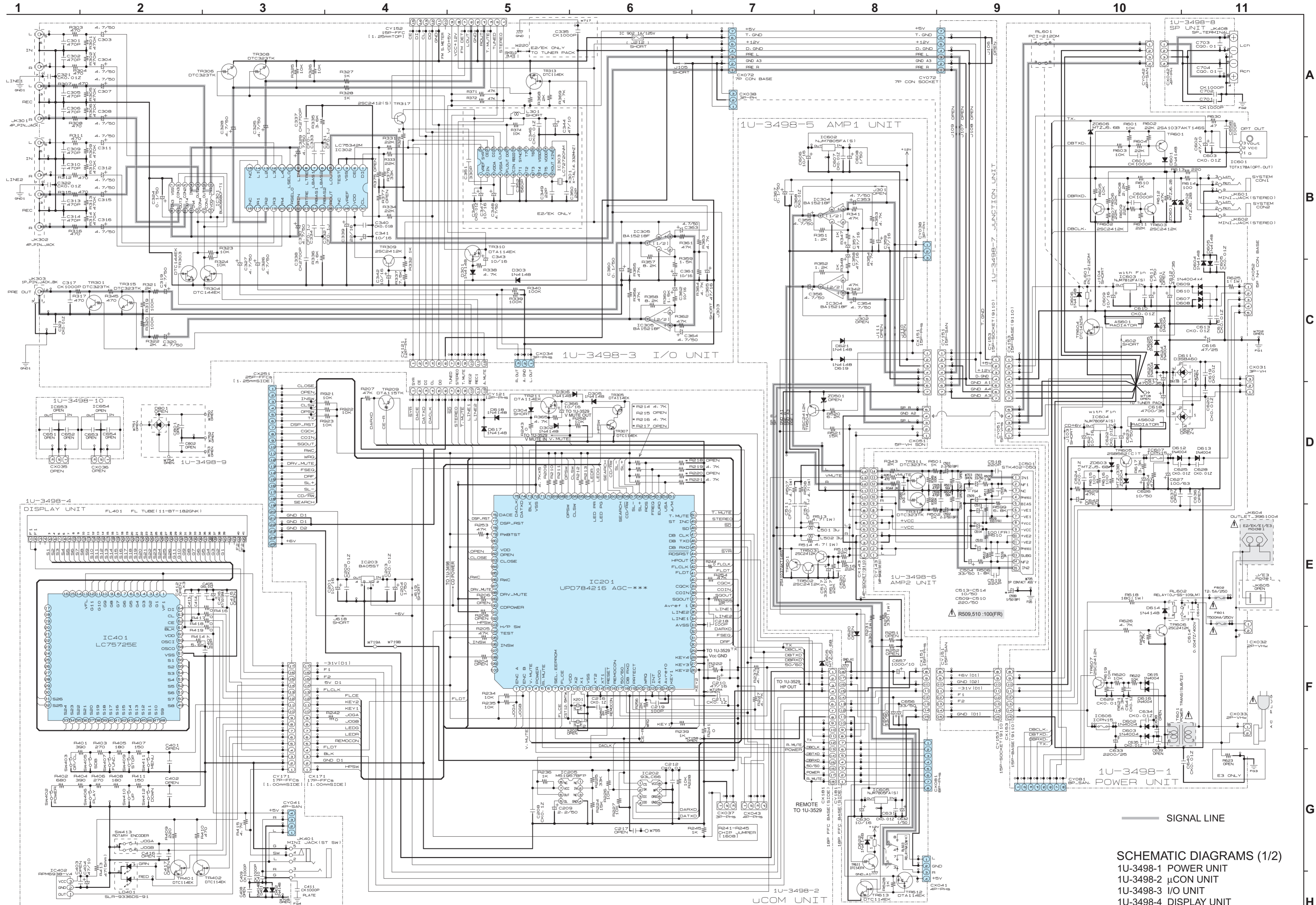

SCHEMATIC DIAGRAMS (1/2)
 1U-3498-1 POWER UNIT
 1U-3498-2 μCON UNIT
 1U-3498-3 I/O UNIT
 1U-3498-4 DISPLAY UNIT
 1U-3498-5 AMP1 UNIT
 1U-3498-6 AMP2 UNIT
 1U-3498-7 JUNCTION UNIT
 1U-3498-8 SP UNIT

1 2 3 4 5 6 7 8 9 10 11

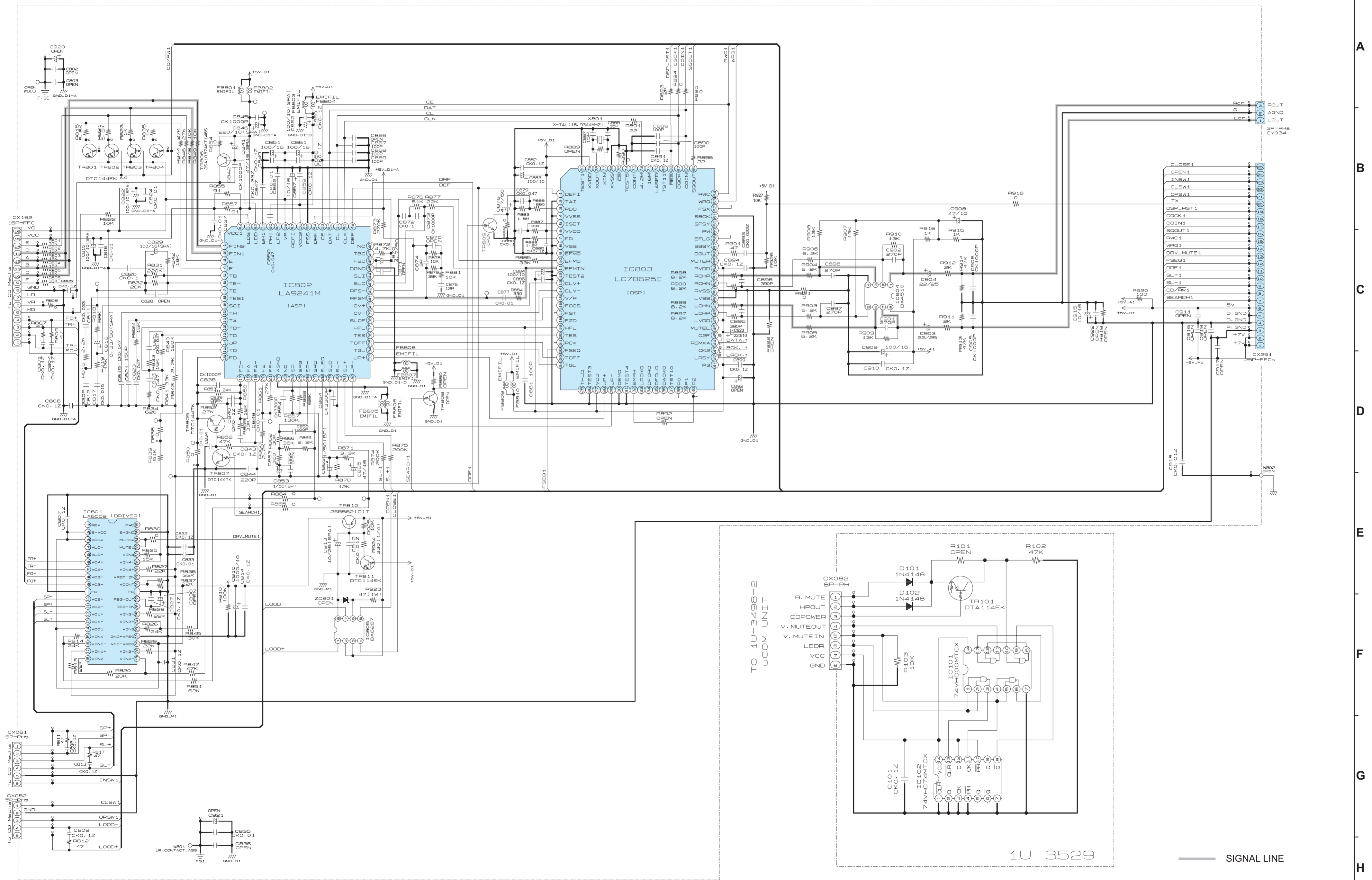

TO 1U-3498-2
UCOM UNIT

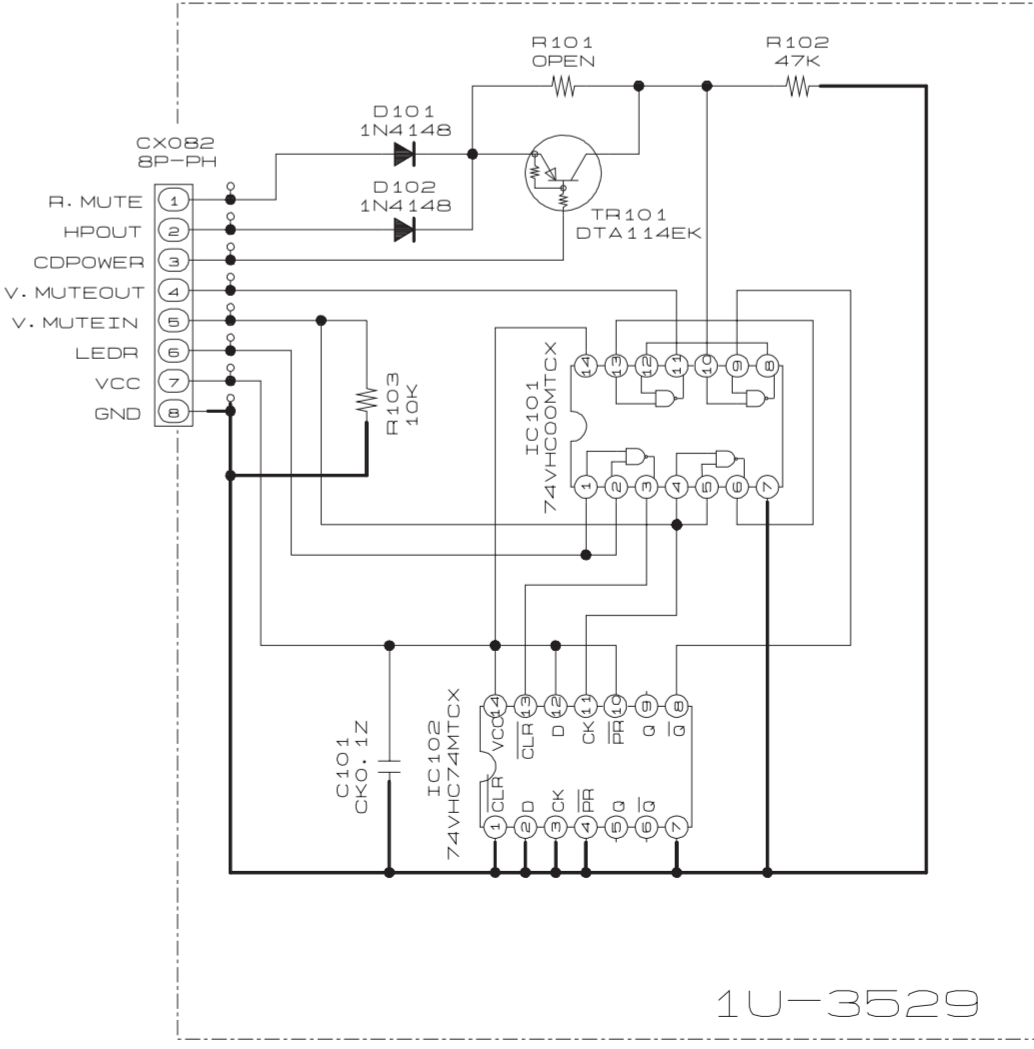

Counter measure for E2 mode1 1~5000 and EK mode1 1~7000

— SIGNAL LINE